



**SUSTAINABLE AGRICULTURE AND RURAL
DEVELOPMENT IN TERMS OF THE REPUBLIC
OF SERBIA STRATEGIC GOALS REALIZATION
WITHIN THE DANUBE REGION**

**- development and application of
clean technologies in agriculture -**

Thematic Proceedings



INSTITUTE OF AGRICULTURAL ECONOMICS BELGRADE

Volgina 15 Street, 11060 Belgrade, Serbia

Phone/Fax: +381 (0) 11 69 72 858

Phone: +381 (0) 11 69 72 848



E-mail:

office@iep.bg.ac.rs

Internet address:

www.iep.bg.ac.rs



SUSTAINABLE AGRICULTURE AND RURAL DEVELOPMENT IN TERMS OF THE REPUBLIC OF SERBIA STRATEGIC GOALS REALIZATION WITHIN THE DANUBE REGION

***- development and application of
clean technologies in agriculture -***

THEMATIC PROCEEDINGS

Belgrade, 2017

Welcome to Serbia and Belgrade



Publisher:

Institute of Agricultural Economics, Belgrade, Serbia

Editors:

**Jonel Subić, Ph.D.
Boris Kuzman, Ph.D.
Andrei Jean Vasile, Ph.D.**

Technical arrangement and printing:

**MALA KNJIGA SZR, Novi Sad
Zetska 15
Phone: +381 (0) 21 64 00 578**

Technical preparation and page breaking:

**Radojica Sarić, Ph.D., Predrag Vuković, Ph.D.,
Biljana Grujić, B.Sc., Bojana Bekić, B.Sc.**

Number of copies:

300

ISBN 978-86-6269-056-2

The publishers are not responsible for the content of the Scientific Papers and opinions published in the Thematic Proceedings. They represent the authors' point of view.

Publication of Thematic Proceedings was financed by the Ministry of Education, Science and Technological Development of the Republic of Serbia.

Organizers

1. INSTITUTE OF AGRICULTURAL ECONOMICS, BELGRADE – SERBIA
Prof. *Jonel Subić*, Ph.D.

Co-organizers

1. BELGRADE CHAMBER OF COMMERCE – SERBIA
Milivoje Miletić, B.Sc.
2. FACULTY OF AGRICULTURE, NOVI SAD – SERBIA
Prof. *Nedeljko Tica*, Ph.D.
3. FACULTY OF ECONOMICS, SUBOTICA – SERBIA
Prof. *Aleksandar Grubor*, Ph.D.
4. INSTITUTE FOR SCIENCE APPLICATION IN AGRICULTURE, BELGRADE – SERBIA
Snežana Janković, Ph.D.
5. INSTITUTE OF ECONOMIC SCIENCES, BELGRADE – SERBIA
Prof. *Jovan Zubović*, Ph.D.
6. FACULTY OF ECONOMICS, KRAGUJEVAC – SERBIA
Prof. *Petar Veselinović*, Ph.D.
7. FACULTY OF HOTEL MANAGEMENT AND TOURISM, UNIVERSITY OF KRAGUJEVAC, VRNJAČKA BANJA – SERBIA
Prof. *Drago Cvijanović*, Ph.D.
8. UNIVERSITY BUSINESS ACADEMY, FACULTY OF ECONOMICS AND ENGINEERING MANAGEMENT, NOVI SAD – SERBIA
Prof. *Dragan Soleša*, Ph.D.
9. UNIVERSITY EDUCONS, SREMSKA KAMENICA – SERBIA
Prof. *Aleksandar Andrejević*, Ph.D.
10. BUCHAREST UNIVERSITY OF ECONOMIC STUDIES, FACULTY OF AGRO-FOOD AND ENVIRONMENTAL ECONOMICS, BUCHAREST – ROMANIA
Prof. *Dan Boboc*, Ph.D.
11. FEDERAL INSTITUTE OF AGRICULTURAL ECONOMICS, VIENNA – AUSTRIA
Thomas Resl, M.Sc.
12. PETROLEUM - GAS UNIVERSITY OF PLOIESTI, FACULTY OF ECONOMICS SCIENCE PLOIESTI – ROMANIA
Prof. *Daniela Buzoianu*, Ph.D.
13. NATIONAL INSTITUTE FOR ECONOMIC RESEARCH, ROMANIAN ACADEMY, BUCHAREST – ROMANIA
Prof. *Luminita Chivu*, Ph.D.
14. MOSCOW UNIVERSITY OF FINANCE AND LAW (MFUA), MOSCOW – RUSSIA
Prof. *Alexey Zabelin*, Ph.D.
15. NATIONAL INSTITUTE FOR ECONOMIC RESEARCH, CHISINAU – MOLDOVA
Prof. *Alexandru Stratan*, Ph.D.

HONORARY BOARD

- *Mladen Šarčević*, Minister of Education, Science and Technological Development of the Republic of Serbia, Belgrade – Serbia
- *Branislav Nedimović*, Minister of Agriculture and Environment Protection of the Republic of Serbia, Belgrade – Serbia
- *Vuk Radojević*, M.Sc., Provincial Secretary for Agriculture, Water Management and Forestry, Government of the Autonomous Province of Vojvodina, Novi Sad – Serbia
- *Prof. Vladimir Popović*, Ph.D., State Secretary of the Ministry of Education, Science and Technological Development of the Republic of Serbia, Belgrade – Serbia
- *Prof. Ana Langović Miličević*, Ph.D., State Secretary of the Ministry of Education, Science and Technological Development of the Republic of Serbia, Belgrade – Serbia
- *Željko Radošević*, B.Sc., State Secretary of the Ministry of Agriculture and Environment Protection of the Republic of Serbia, Belgrade – Serbia
- *Milivoje Miletić*, B.Sc., President of Belgrade Chamber of Commerce, Belgrade – Serbia
- *Svetozar Krstić*, M.Sc., Executive Director of Belgrade Chamber of Commerce, Belgrade – Serbia
- *Academician prof. Dragan Škorić*, Ph.D., President of the Committee for the Village of Serbian Academy of Sciences and Arts, Belgrade – Serbia
- *Prof. Nedeljko Tica*, Ph.D., Dean of the Faculty of Agriculture, Novi Sad – Serbia
- *Prof. Aleksandar Grubor*, Ph.D., Dean of the Faculty of Economics, Subotica – Serbia
- *Snežana Janković*, Ph.D., Director of the Institute for Appliance of Science in Agriculture, Belgrade – Serbia
- *Prof. Danilo Tomić*, Ph.D., President of the Executive Board of Institute of Agricultural Economics, Belgrade – Serbia
- *Prof. Natalija Bogdanov*, Ph.D., Member of the Executive Board of Institute of Agricultural Economics, Belgrade – Serbia
- *Prof. Milan Milanović*, Ph.D., Member of the Executive Board of Institute of Agricultural Economics, Belgrade – Serbia
- *Prof. Radovan Pejanović*, Ph.D., President of the Balkan Scientific Association of Agricultural Economics, Belgrade – Serbia
- *Prof. Drago Cvijanović*, Ph.D., Dean of the Faculty of Hotel Management and Tourism, University of Kragujevac, Vrnjačka Banja – Serbia
- *Prof. Dragana Gnjatović*, Ph.D., Faculty of Hotel Management and Tourism, University of Kragujevac, Vrnjačka Banja – Serbia
- *Prof. Nicolae Istudor*, Ph.D., Rector of the Bucharest University of Economic Studies, Bucharest – Romania
- *Prof. hab. Andrzej Kowalski*, Ph.D., Director of the Institute of Agricultural and Food Economics, Warsaw – Poland
- *Prof. Vladimir I Trukhachev*, Ph.D., Rector of the Stavropol State Agrarian University, Stavropol – Russia
- *Prof. Andreica Romulus*, Ph.D., Rector of the Commercial Academy of Satu Mare, Satu Mare – Romania
- *Prof. Alexandru Stratan*, Ph.D., Director of the National Institute for Economic Research, Chisinau – Moldova

SCIENTIFIC BOARD

- Prof. *Jonel Subić*, Ph.D., Serbia – President
- Doc. *Boris Kuzman*, Ph.D., Serbia – Vice President
- Prof. *Jovan Zubović*, Ph.D., Serbia
- *Ivana Domazet*, Ph.D., Serbia
- Prof. *Wim Heijman*, Ph.D., the Netherlands
- Prof. *Zorica Vasiljević*, Ph.D., Serbia
- Prof. *Koviljko Lovre*, Ph.D., Serbia
- Prof. *Vladislav Zekić*, Ph.D., Serbia
- Prof. *Stanislav Zekić*, Ph.D., Serbia
- Prof. *Jelena Birovljev*, Ph.D., Serbia
- Prof. *Branislav Vlahović*, Ph.D., Serbia
- Prof. *Vladimir Senić*, Ph.D., Serbia
- Doc. *Dejan Janković*, Ph.D., Serbia
- Doc. *Tanja Stanišić*, Ph.D., Serbia
- Doc. *Nebojša Pavlović*, Ph.D., Serbia
- Prof. *Ivan Milojević*, Ph.D., Serbia
- *Bogdan Bazga*, Ph.D., Romania
- *Marek Wigier*, Ph.D., Poland
- *Zbigniew Floriańczyk*, Ph.D., Poland
- Doc. *Vasily Erokhin*, Ph.D., Russia
- Prof. *Mariana Eftimie*, Ph.D., Romania
- Prof. *Dorel Dusmanescu*, Ph.D., Romania
- Prof. *Mirela Stoian*, Ph.D., Romania
- Prof. *Gabriel Popescu*, Ph.D., Romania
- Prof. *Raluca Ion*, Ph.D., Romania
- Prof. *Laszlo Karpati*, Ph.D., Hungary
- Prof. *Andras Nabradi*, Ph.D., Hungary
- Prof. *Gorica Cvijanović*, Ph.D., Serbia
- *Rade Jovanović*, Ph.D., Serbia
- Prof. *Gordana Dozet*, Ph.D., Serbia
- *Ferhat Čejvanović*, Ph.D., Brčko Distrikt, Bosnia and Herzegovina
- *Ivana Plazibat*, Ph.D., Split, Croatia
- *Klaus Dieter Wagner*, Ph.D., Austria
- *Andrei Jean Vasile*, Ph.D., Romania
- *Dragić Živković*, Ph.D., Serbia
- *Marius Voicilas*, Ph.D., Romania
- *Adrian Stancu*, Ph.D., Romania
- *Ana Ursu*, Ph.D., Romania
- *Vlado Kovačević*, Ph.D., Serbia
- *Slađan Stanković*, Ph.D., Serbia
- *Dragan Milić*, Ph.D., Serbia
- Prof. *Andreica Marin*, Ph.D., Romania
- *Vesna Popović*, Ph.D., Serbia
- *Branko Mihailović*, Ph.D., Serbia
- *Anton Puškarić*, Ph.D.
- *Vesna Paraušić*, Ph.D., Serbia
- *Nataša Kljajić*, Ph.D., Serbia
- *Zoran Simonović*, Ph.D., Serbia
- *Ljiljana Rajnović*, Ph.D., Serbia
- *Svetlana Roljević*, Ph.D., Serbia
- *Vladimir Filipović*, Ph.D., Serbia
- *Vladan Ugrenović*, Ph.D., Serbia
- Doc. *Tatjana Papić Brankov*, Ph.D., Serbia

ORGANIZATIONAL BOARD

- *Radojica Sarić*, Ph.D.
- *Predrag Vuković*, Ph.D.
- *Biljana Grujić*, B.Sc.
- *Bojana Bekić*, B.Sc.
- *Nada Mijajlović*, M.Sc.
- *Slavica Arsić*, M.Sc.
- *Velibor Potrebić*, M.Sc.
- *Lana Ivanović*, M.Sc.
- *Marko Jeločnik*, M.Sc.
- *Marijana Jovanović*, B.Sc.
- *Ljiljana Stojkov*, B.Sc.
- *Miodrag Veseli*, B.Sc.
- *Velimir Radojević*, M.Sc.
- *Irena Kaljević Zimonja*, B.Sc.
- *Emil Čukić*, B.Sc.
- *Ivana Vučetić*
- *Vesna Stajčić*
- *Milena Marinković*
- *Boban Zarić*

PREFACE

The Thematic Proceedings was prepared as the result of the scientific research on the integrated and interdisciplinary project no. III 46006: *Sustainable agriculture and rural development in terms of the Republic of Serbia strategic goals realization within the Danube region.*

Thematic Proceedings includes selected papers presented at the International Scientific Conference - Sustainable agriculture and rural development in terms of the Republic of Serbia strategic goals realization within the Danube region: Development and implementation of clean technologies in agriculture, which was hold in Belgrade during the December 2016.

Besides the papers from Serbia in Thematic Proceedings are also included the invited papers prepared by foreign authors, which are associates of the IAE Belgrade and whose institutions have close scientific, business and technical cooperation with IAE Belgrade.

The Thematic Proceedings addresses the wider audience of stakeholders scientifically and practically focused to all segments of agriculture.

Publisher and editors are not responsible for the content of the scientific papers and opinions published in the Thematic Proceedings, as they represent the authors' point of view.

Publishing of Thematic Proceedings was financially supported by the Ministry of Education, Science and Technological Development of the Republic of Serbia.

In Belgrade

February, 2017

Editors:

Jonel Subić, Ph.D.

Boris Kuzman, Ph.D.

Andrei Jean Vasile, Ph.D.

Contents

PLENARY SECTION

INVITED PAPER

1. *Andrei Jean Vasile, Alecu Alexandra*: **DETERMINANTS OF AGRICULTURAL RENEWABLES PRODUCTION FROM THE PERSPECTIVE OF LAND USE PARADIGM, AGRICULTURAL PRICES AND COMMERCE IN ROMANIA AND SOME EU-28 COUNTRIES**..... 1-18
2. *Barbara Wieliczko*: **ROLE OF PUBLIC POLICY IN DEVELOPMENT AND APPLICATION OF CLEAN TECHNOLOGY IN THE POLISH AGRICULTURE**..... 19-36
3. *Jonel Subić, Marko Jeločnik*: **ECONOMIC EFFECTS OF THE SOLAR AND WIND ENERGY USE IN IRRIGATION OF VEGETABLE CULTURES** 37-55
4. *Nicolò Colombani, Giuseppe Castaldelli*: **NITRATE PERSISTENCE IN FERRARA (IT) AGRICULTURAL LANDS, PAST ACHIEVEMENTS AND NEW PERSPECTIVES**..... 56-72
5. *Raluca Andreea Ion, Dorel Dusmanescu*: **INFLUENCES OF INTERNATIONAL TRADE ON FOOD SECURITY** 73-88
6. *Vassilis Aschonitis, Micòl Mastrocicco*: **INTRINSIC VULNERABILITY OF AGRICULTURAL LANDS TO WATER AND NITROGEN LOSSES** 89-106
7. *Željko Despotović, Miloš Jovanović, Ilija Stevanović*: **POSSIBILITIES OF USING RENEWABLE ENERGY SOURCES IN AGRICULTURE OF THE REPUBLIC OF SERBIA**..... 107-128

I SECTION

TECHNICAL AND TECHNOLOGICAL PROGRESS AND THE SUSTAINABLE MANAGEMENT OF RESOURCES IN AGRICULTURE

1. *Dragić Živković, Đina Đekić: HUMAN RESOURCE MANAGEMENT IN BUSINESS SYSTEM OF INFORMATION TECHNOLOGY*.....129-146
2. *Jelena Karapandžin, Vesna Rodić: THE USE OF THE THEORY OF PLANNED BEHAVIOUR IN THE ANALYSIS OF ENVIRONMENTAL AWARENESS*.....147-163
3. *Lela Ristić, Vladimir Mičić: ORGANIC AGRICULTURE AS A DETERMINANT OF SERBIAN AGRI-FOOD SECTOR DEVELOPMENT*164-180
4. *Ljiljana Rajnović, Biljana Grujić: THE POSSIBILITY OF ASSOCIATION OF WATER USERS IN IRRIGATION IN AGRICULTURE*.....181-196
5. *Marina Novakov, Dejan Janković: EDUCATION AS A FACTOR OF TECHNOLOGICAL PROGRESS AND DETERMINANT OF HUMAN RESOURCES IN AGRICULTURE*.....197-215
6. *Mihailo Ratknić, Sonja Braunović: THE POSSIBILITY OF ESTABLISHING SHORT ROTATION COPPICES FOR ENERGY PURPOSES IN THE KOLUBARA DISTRICT*216-233
7. *Nataša Kljajić: ANALYSIS OF CONDITIONS AND RESULTS OF THE RASPBERRY PRODUCTION IN ARILJE RASPBERRY-MOUNT*.....234-253
8. *Stanislav Zekić, Bojan Matkovski: SUSTAINABLE DEVELOPMENT OF AGRICULTURE IN SERBIA AS A FUNCTION OF RURAL DEVELOPMENT*.....254-269
9. *Željko Vojinović, Drago Cvijanović: RISKS IN THE PRODUCTION OF ORGANIC FOOD*270-291

II SECTION

OPTIMIZATION OF AGRICULTURAL PRODUCTION, IMPROVEMENT OF QUALITY AND PRODUCT REALIZATION

1. *Boris Kuzman, Radivoj Prodanovic*: **LAND MANAGEMENT IN MODERN FARM PRODUCTION**.....292-308
2. *Catalin Voica, Mirela Panait*: **STEPS TO LIBERALIZATION OF INTERNATIONAL TRADE WITH AGRICULTURAL PRODUCTS**.....309-325
3. *Dejan Đurić, Dragana Đurić*: **STATE AND PERSPECTIVES OF FOREIGN TRADE EXCHANGE OF FRUIT - THE EXAMPLE OF SERBIA**.....326-341
4. *Ferhat Čejvanović, Vladimir Filipović, Adnan Kamerić*: **APPLICATION OF NEW TECHNOLOGIES AND PRECISION AGRICULTURE**342-359
5. *Ivan Milojević, Mihailo Ćurčić*: **ROLE OF THE BUDGET IN FINANCING OF AGRICULTURE**360-373
6. *Maja Ćirić, Svetlana Ignjatijević*: **THE INFLUENCE OF DEMOGRAPHIC CHARACTERISTICS OF CONSUMERS ON HONEY BUYING BEHAVIOUR**.....374-392
7. *Stefan Milanović, Jelena Ristić*: **LOAN AGREEMENTS OF THE IFC IN THE PERSPECTIVE OF AGRICULTURAL FINANCING**393-411
8. *Tatjana Brankov, Koviljko Lovre*: **IS IT TIME FOR FAIRTRADE MILK IN SERBIA?**.....412-429
9. *Vlado Kovačević, Zorica Vasiljević*: **DEVELOPMENT OF COMMODITY EXCHANGES IN FUNCTION OF AGRIBUSINESS IN SERBIA**430-445
10. *Zoran Simonović, Branko Mihailović*: **AGRICULTURAL PRODUCTION IN THE REPUBLIC OF SERBIA WITH EMPHASIS ON THE SITUATION IN NISAVA DISTRICT**446-462

III SECTION

THE APPLICATION OF CLEAN TECHNOLOGIES IN THE FUNCTION OF DIVERSIFICATION OF THE RURAL ECONOMY

1. *Adrian Ungureanu, Bogdan Bazga*: **RURAL TOURISM IN THE SOUTH-MUNTENIA DEVELOPMENT REGION**.....463-491
2. *Jelena Matijašević-Obradović, Maja Kovačević*: **THE IMPORTANCE OF THE ICT FOR THE PURPOSE OF INCREASING COMPETITIVENESS OF RURAL AREAS**492-509
3. *Jelena Petrović, Snežana Milićević*: **INTERNET IN THE DEVELOPMENT OF RURAL TOURISM IN THE DANUBE RIVER BASIN IN SERBIA**.....510-528
4. *Jovana Čikić, Marica Petrović*: **ENVIRONMENTAL SUSTAINABILITY IN RURAL TOURISM**529-547
5. *Marijana Joksimović, Stevica Deđanski*: **THE DEVELOPMENT OF SUSTAINABLE TOURISM AS A COMPONENT OF ECONOMIC DEVELOPMENT OF THE REPUBLIC OF SERBIA**548-566
6. *Miljana Barjaktarović, Želimir Ilić*: **CHALLENGES OF CONTEMPORARY CAPITAL MARKET IN TRANSITION TO GREEN ECONOMY**567-583
7. *Nenad Gvozdenović*: **PRESENTATION IMPLEMENTATION OF IMPROVED LC MODEL IN SERBIA IN ACCORDANCE WITH THE BEST EU PRACTICE WITHIN THE GIZ PROJECT**584-594
8. *Svetlana Roljević Nikolić, Predrag Vuković*: **SUPPORT ORGANIC FARMING AS A CLEAN TECHNOLOGY AND DEVELOPMENT OF RURAL AREAS IN THE EU AND SERBIA**.....595-612
9. *Vesna Paraušić*: **RENEWABLE ENERGY AND ENERGY EFFICIENCY IN AGRICULTURE AND RURAL AREAS IN SERBIA**.....613-630

PLENARY SECTION

INVITED PAPER

DETERMINANTS OF AGRICULTURAL RENEWABLES PRODUCTION FROM THE PERSPECTIVE OF LAND USE PARADIGM, AGRICULTURAL PRICES AND COMMERCE IN ROMANIA AND SOME EU-28 COUNTRIES

Andrei Jean Vasile¹, Alecu Alexandra²

Abstract

Renewable energies have become an important and debate full topic both in literature and society in the context of energy security paradigm. In this context agricultural renewable energies may represent a viable solution in reduce the energy dependence form extra EU energy imports. The transformation of the energy policy paradigm and promoting the agricultural renewable energies raise numerous topics of debate, including aspects of food safety and security. The main aim of the paper is analysis of the influence and determinants of agricultura renewables production from the perspective of land use paradigm, agricultural prices and commerce in Romania form an EU-28 perspective.

Keywords: *Renewable energies, biodiesels, biogasoline, energy paradigm.*

Introduction

Significant transformations of European agricultural paradigm imposed agricultural sector to rethink its traditional functions, this new aspects acquiring multiple functions. Agriculture acquired new features and functions, that transcend their classic role to ensure food security of the population. Thus, as a result of economic growth and consequently the needs of energy, agriculture was transformed from a potential supplier of renewable energy in stable source of energy production by promoting the cultivation of energy plants, widely supported financially by the European mechanisms.

¹Andrei Jean Vasile, Ph.D., Associate professor, Petroleum-Gas University of Ploiesti, Faculty of Economic Sciences, B-dul Bucuresti no. 39, 100680, Ploiesti, Prahova, Romania, Phone: +40 721 146 587, E-mail: ajvasile@upg-ploiesti.ro

²Alecu Alexandra, MA student, Petroleum-Gas University of Ploiesti, Faculty of Economic Sciences, B-dul Bucuresti no.39, 100680, Ploiesti, Prahova, Romania, E-mail: alexandra.alecu22@yahoo.com

The new European energy paradigm based on power production from renewable sources, including the promotion of energy crops involves an extensive transformation process that includes on the one hand energy supply, therefore the production and the energy sector as a whole, and on the other part includes energy and imperatives of economic efficiency, both in terms of economic and social costs, environmental sustainability and sustainability of economic development.

Renewable energy has become lately a growing option worth taking into account in the context of geopolitical and geostrategical transformations that have highlighted insecurity of both classic energy supply sources and transport routes and networks. From this perspective, the promotion of renewable energy is a viable tool in the economic development and in achieving sustainable well-being and social development. Space Energy Community is characterized by the existence of three types of major, obvious inequalities: on the one hand the existence of a dependent accentuated over the resources of classic energy imported from Russia, and uneven dispersion of renewable energy sources in the European territory and, on the other hand, energy production from agriculture and promotion of agricultural fuels.

Development of renewable energy production is limited by a number of obstacles and determining factors. They have a diverse nature and very complex, being both legislative or institutional, but especially the technical and financial considering the fact that most times the production of renewable energy is less competitive than the conventional-classical and internalisation is increasingly more difficult to achieve. Although specialized studies (Badea and Mieila, 2008; Andrei and Ungureanu, 2014 Andrew, 2015; Andrew et al., 2016) most often report that the production of renewable energy from agricultural sources can be, from this perspective, a viable solution reducing dependence on conventional energy resources, the problem is complex and has deep meanings on agricultural production paradigm. Vasile et al, 2016 implications of agricultural bioenergy crop production and prices in changing the land use paradigm in case of Romania are multiple and for a long period of time. Thus, it has been proved that by promoting the production of renewable energy from agricultural sources has a significant influence on the national agricultural production paradigm. Areas cultivated with agricultural plants needed to ensure food for population and animals has significantly been reduced especially due to the financial support through the PAC mechanism and higher prices especially for sunflower and rapeseed. On the other hand (Dusmanescu et al, 2016)

performs a heuristic methodology for estimating the potential biofuel liquid of the region, with application in the case of Romania, reaching the conclusion that there is a potential for energy production from renewable sources, but its use should be on the degraded lands that can not be used and attracted in the aside and biomass to constitute not only the cultivation of energy plants but the plants' remains useful in the production of renewable energy. The restructuring of European agricultural sector in order to promote renewable energy production of agricultural origin raise many questions. Agriculture through its primordial and classic function must ensure food production needed to satisfy the need of the population, inslusiv a maximum fence of achieving food security, and then of objective complementary with the production of bioenergy. In this context, as was argued by (European Economic and Social Committee, 2008), attempts to replace part of the two conventional transport fuels categories - diesel or petrol by agrofuels is one of the least effective and most expensive environmental protection measures, which generated significant transformation of agricultural production paradigm. Thus, according to (European Commission, 2008), the Directive of the European Parliament and of the Council on the promotion of renewable energy have not only defined quantitative targets by setting of mandatory renewable energy but has also tried a regulatory much larger, which took into account a number of issues such as (COM (2008) 19 final):

- Establishing criterias regarding the environmental sustainability of agro-fuels and the importance and their effect on the climate;
- Defining the calculation of the mandatory quota of energy coming from renewable sources, including the issue of imports of these energies;
- Issues guarantees of origin;
- Principles and regulations on access to the electricity grid;
- The framework conditions for national subsidies and limit the effects of distortion of competition and tax regime.

Analysis of European policy to promote the use of energy from renewable agricultural nature involves a much larger framework of discussions than previously realized. The implications are complex and promoting discussions on the effects of such products are numerous in the literature and not a study objective in this paper. This paper aims to analyze the evolution of the production of biodiesel and biogasoline at the level of the EU-28 states and Romania and some complementary aspects such as the acreage evolution of energy plants in Romania, the trade balance of technical products energy and share price in the period 2007-2014 or 2015 where data are available.

Aspects on evolution and transformations of primary renewable energy the European economic space

The evolution of renewable energy production is a sign of interest in terms of promoting alternative energy sources, particularly due to the deepening of the agricultural nature. Thus, the first component envisaged in this analysis is the evolution of the production of biodiesel. Table 1 shows the evolution of primary production of renewable biodiesels in some EU-28 countries, during 2007-2014, expressed in their respective absolute values, 1000 tonnes of oil equivalent, and in Fig. 1 in relative values compared to the EU-28 average.

Table 1. *Primary production of renewable biodiesels in some EU-28 countries (1 000 tonnes of oil equivalent)*

Country	2007	2008	2009	2010	2011	2012	2014	$\Delta_{2007-14}$
EU-28	5326.3	6655.2	7984.7	8907.3	8486.5	9102.4	11248.9	5922.6
Bulgaria	0	8.7	10.8	11.0	14.1	7.1	54.5	54.5
Czech Rep.	72.3	67.8	136.9	175	185.7	152.6	193.8	121.5
Germany	2633.1	2236.6	2158.5	2736	2721.9	2492	3042.6	409.5
Spain	161.5	198.2	652.1	754.7	609	444.6	1070.8	909.3
France	850.7	1567.8	1856	1774	1618.6	1944.7	2074.5	1223.8
Italy	178.5	590.3	705.5	706.1	522.5	253.6	512.1	333.6
Latvia	8.1	25	39.9	38.6	53.2	80.4	66.6	58.5
Lithuania	21.9	57.1	92.5	78.8	70.6	94.3	105.8	83.9
Hungary	8.2	122.7	112.3	126.6	127	128.9	119.2	111
Austria	226.9	219.3	234	241.9	208.5	181.8	234.4	7.5
Poland	43.5	237.5	333.9	348.1	333.2	555.2	653	609.5
Portugal	159.5	144.5	221.8	279.7	323.1	268.8	286.5	127
Romania	19.6	81.6	72.3	10.8	94.1	88.7	96.9	77.3
Slovakia	44.6	100.8	99.7	111.7	114.6	99.3	92.8	48.2
UK	380	253	176.3	138	158.9	221.3	126.8	-253.2

Source: EUROSTAT, 2016a

The data presented in Table 1 taking into account the primary production of renewable energy biodiesels in some EU-28 countries, it can be noticed that, per ensemble analysis, although a falling by 420.8 tonnes of oil equivalent to 1000 has been recorded between 2010-2011, in the period 2007-2014, EU-28 saw an increase in the production of renewable energy biodiesels, from 5326.3 tonnes of oil equivalent at 11248.9 tonnes of oil equivalent. The oscillating evolution of production of biodiesel can be appreciated as following the general imposed trend of supporting financial measures of energy crops and substantiation of the new European energy paradigm.

Given the same data presented in Table 1 it can be noted that Romania also recorded an increase during this period, 77.3 tonnes of oil equivalent, from 19.6 tonnes of oil equivalent in 2007, reaching 96.9 tonnes of oil equivalent in 2014. Although the trend has been growing, in Romania's case, the production of biodiesel has suffered a decline more pronounced in post-crisis period from 2008 to 2010 than most countries in the EU-28. Thus, in 2010 it was recorded a production of 61.5 tonnes of oil equivalent lower than in 2009.

However, if we consider countries with a long tradition of promoting the production of biodiesel in the EU-28, such as Germany, which developed and applied public policy support and implementation of biofuels, a decrease very small was registered in post-crisis period, 78.1 tonnes of oil equivalent in 2009, compared to 2008, then production rebounding considerably in 2010, with an increase of 499.4 tonnes of oil equivalent compared to 2008, continuing an upward trend, reaching 2014 a production of 3042.6 tonnes of oil equivalent. In order to complete the analysis, in Fig.1 is presented the relative evolution of biodiesel production in some EU-28 countries, during 2007-2014.

Fig. 1. Evolution of renewable biodiesels production in some EU-28 countries (EU-28=100)

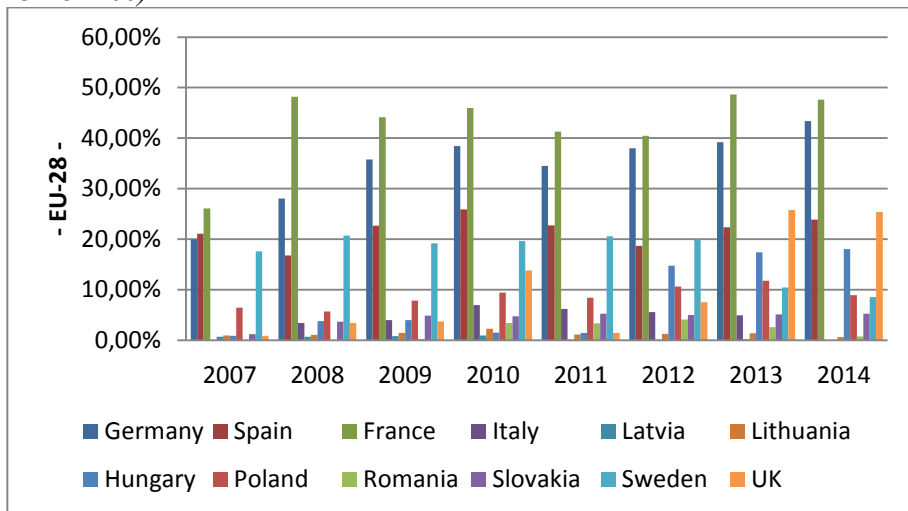

Source: authors` own computation based on Table 1

In Fig.1 it may be noted that if at the beginning of the review period, respectively in 2007, the highest values calculated were recorded in the case of countries such as France (26.09%), Spain (21.10%), Germany

(19.93%) and Sweden (17.60 %), seven years later highest values were recorded in the cases of nearly identical states, with the remark that France (47.60%) and Germany (43.40%) registered a twofold increase compared to the average EU-28, while in the case of Spain a slight increase reaching 23.88% is recorded. Significant increases are recorded in 2014 but for Hungary which reaches 18.07% from 0.88% in 2007 and UK from 0.85% in 2007 to 25.37% in 2007. However, Sweden shows a dramatic drop from 17.60% in 2007 to 8.56% in 2014. Analyzing the relative evolution of biodiesel production by reporting information to the EU-28 average values recorded at each year had in the analysis, it can be seen more directly toward the production of bioenergy guidelines states of biofuel. In Fig.1 three categories of states can be identified: a first group of states that have chosen to promote the primary production of renewable biodiesels such as the Germany, France or Spain, a number of states that have chosen to change the paradigm of production, reducing the production of biodiesel as is the case of Sweeden, Lithuania or Italy and a last category of states formed by the majority of EU-28 member states that have aligned with European legislation in the field of biofuels.

The second category contemplated in this article was the primary production of renewable biogasoline. Biogasoline is a component that has a much lower share than biodiesel, but is in a continuous raise. In Fig.2 is presented the evolution of primary production of renewable biogasoline in some EU-28 countries, 2007-2014.

Fig. 2. Evolution of renewable biogasoline production in some EU-28 countries, 2007-2014

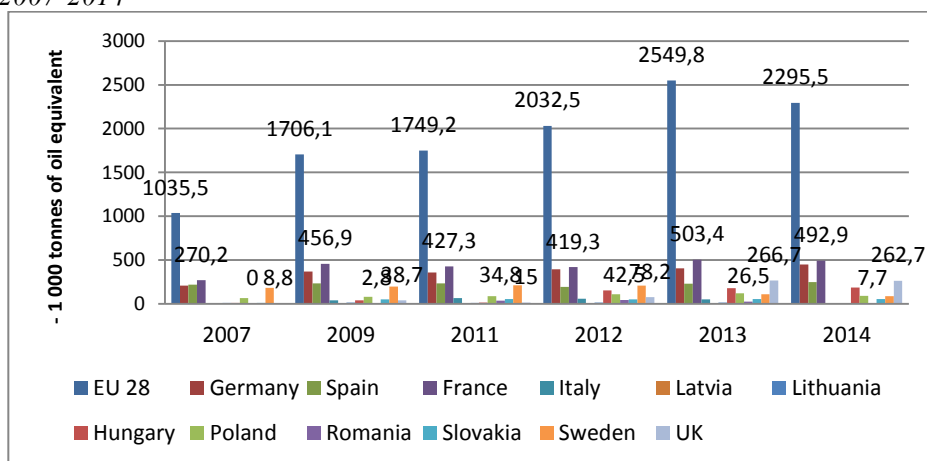

Source: authors based on EUROSTAT, 2016b

From Fig.2 evolution of primary production of renewable energy of biogasoline in some EU-28 countries, it is observed that developed countries such as Germany, UK and France for an deeply increase in renewable energy of biogasoline production during 2007-2014, while in the case of members which joined in the wave one and two at EU, such as Romania, Lithuania, Latvia, recorded considerable declines in production of renewable energy biogasoline. However, overall in the EU-28 is observed fluctuations in the production of biogasoline the parks 2007-2014 period, but overall, there is an increase of 1,260 tonnes of oil equivalent. In Romania, there is a slight increase of renewable energy of biogasoline production since 2009, from 2.8 tonnes of oil equivalent of primary production of renewable energy of biogasoline, up to 42.5 tonnes of oil equivalent in year 2012 followed by a sharp decline to a production of 7.7 tonnes of oil equivalent registered in 2014. On the other hand, in countries where it is emphasised the development of renewable energy production, a significant growth is recorded. UK recorded during 2007-2014 a growth of almost 30 times higher from 8.8 tonnes of oil equivalent in 2007, to a production of 262.7 tonnes of oil equivalent in 2014. Also, France and Germany doubles its biogasoline production in the analyzed period. From this perspective of particular importance share of renewable energy in gross final energy consumption. Table 2 presents this indicator.

Table 2. *Share of renewable energy in gross final energy consumption (%)*

	2007	2008	2009	2010	2011	2012	2013	2014	$\Delta_{2007-14}$
EU-28	10.4	11	12.4	12.8	13.1	14.3	15	16	5.6
Bulgaria	9.2	10.5	12.1	14.1	14.3	16	19	18	8.8
Czech Rep.	7.4	7.6	8.5	9.5	9.5	11.4	12.4	13.4	6.0
Germany	9.1	8.6	9.9	10.5	11.4	12.1	12.4	13.8	4.7
Spain	9.7	10.8	13	13.8	13.2	14.3	15.3	16.2	6.5
France	10.2	11.1	12.1	12.6	11.1	13.4	14	14.3	4.1
Latvia	29.6	29.8	34.3	30.4	33.5	35.7	37.1	38.7	9.1
Lithuania	16.7	18	20	19.8	20.2	21.7	23	23.9	7.2
Hungary	5.9	6.5	8	8.6	9.1	9.6	9.5	9.5	3.6
Poland	6.9	7.7	8.7	9.2	10.3	10.9	11.3	11.4	4.5
Romania	18.3	20.5	22.7	23.4	21.4	22.8	23.9	24.9	6.6
Slovenia	15.6	15	20	20.5	20.2	20.9	22.5	21.9	6.3
Slovakia	7.8	7.7	9.4	9.1	10.3	10.4	10.1	11.6	3.8
UK	1.8	2.7	3.3	3.7	4.2	4.6	5.6	7.0	5.2

Source: *authors based on Eurostat, 2016c*

Promotion of renewable energy production in the EU-28 states contributed, naturally, to increase the share of this category in total energy consumption. Starting from the premise that renewable energy sources are available at levels locally in the case of each member state with a degree of

decentralization, promoting their capitalization in a fence higher, can help to reduce the consumption of classical energy sources more volatile and vulnerable to geopolitical changes. Regarding the share of Renewable Energy in gross final energy consumption (%) pointed out that at EU-28 level, there is a continuous increase in the renewable energy share of total energy consumed, the consumption increased by 5.6% in the period of 2007-2014. Although at a first analysis it can be said that this increase is relatively insignificant, over the period analyzed at the EU-28 level the values are positive for all countries considered in the analysis, highlights the positive effects of the change of paradigm in European energy policy. From Table 2 it can be seen that the largest share of renewable energy in gross final energy consumption in the period 2007-2014, are registered in Latvia and Finland, from 29.6% in 2007 to 38.7% in year 2014. And the lowest values of share of renewable energy in gross final energy consumption are registered in the UK and Ireland, which, even if for an increase in the analyzed period, they are considerably lower than in other countries. UK recorded a growth of 1.8% in 2007 to 7% in 2014 and Ireland in 2007 recorded a share of renewable energy in gross consumption by 3.6%, increasing to 8.6% in 2014. Although despite a growing share of renewable energy consumption in the final energy consumption at the EU-28 is noticed, we consider that biofuels of agricultural origin can not constitute a lasting and sustainable solution to supplement or even replace high specific energy consumption contemporary society. Also biofuels of agricultural origin in terms of availability can not fully replace the classic fuel and completing paradigm shift energy consumption is impossible, at least for a long period of time. In this context this great increase of renewable energy share in gross final European energy consumption should be understood from a much wider perspective. Hence, as it is found in the literature (Lund, 2007) share of renewable energy in gross final energy consumption in the EU-28 increased significantly over recent years. Chien and Hu (2007) analyzing macroeconomic and renewable energy efficiency of OECD and non-OECD economies concludes that non-OECD economies have a renewable energy share higher of supply in their total energy than OECD Economies. This shows that economies with a lower development promote more intensive production of energy from renewable sources.

Changes in cultivated areas with energetic plants in some EU-28 countries

An important aspect taken into account in the study is the analysis of the evolution of cultivated area with energy crops from the European land use

perspective. The evolution of area cultivated with energy plants may represent a significant indicator in understanding the transformations of agricultural paradigms production during the last period. Reorientation of agricultural land to the production of energy crops can be understood from the perspective of correlative financial support for energy crops. In the table is presented evolution of area cultivated with energy plants with rape, turnip rape, sunflower seeds and soya in come EU-28 countries during 2007-2014.

Table 3. *Evolution of area cultivate with energetic plants rape, turnip rape, sunflower seeds and soya (cultivation/harvested/production) (1000 ha)*

Country	2007	2009	2011	2012	2013	2014
EU-28	10454.42	10922.3	11610.7	10966.0	11906.9	11556.2
Bulgaria	-	917.6	979.0	915.5	1013.6	1034.1
Czech Rep.	369.5	386.4	409.5	431.7	446.6	415.1
Germany	1567.4	1494.8	1365.4	1342.6	1499.5	1426.1
Estonia	73.6	82.1	89.0	87.1	86.1	80.0
Ireland	8.1	6.3	12.3	17.4	13.6	9.4
Spain	621.0	874.0	895.6	782.2	908.6	827.4
France	2166.9	2249.3	2338.2	2.324.4	2251.4	2236.1
Italy	263.9	283.2	302.9	275.2	330.5	360.8
Lithuania	174.4	191.9	251.0	263.4	260.4	217.2
Hungary	771.2	827.2	854.4	820.9	836.8	850.4
Poland	800.3	812.4	833.1	724.5	923.3	952.5
Portugal	17.62	21.35	22.42	18.03	18.09	15.55
Romania	1334.0	1234.8	1459.7	1252.1	1418.8	1487.6
Slovenia	5.7	4.7	5.2	5.6	6.6	6.2
Slovakia	228.3	261.3	252.1	218.8	249.9	235.3
Finland	90.3	81.1	91.0	57.4	52.7	43.0
UK	601.6	570.0	705.0	756.0	715.0	675.0

Source: *authors based on EUROSTAT, 2016d*

Agricultural land use for the production of bioenergy can contribute significantly to the rehabilitation of local communities farming by encouraging the accelerated escalating land available or to use those abandoned in but also through protection of agricultural areas already cultivated crops to feed animals and humans. And also can strengthen the capacity of agricultural ecosystems respond to environmental requirements and to fulfill its main functions by generating biomass supplementary, resulting from crop harvesting classic destination for food and biomass results. Analysing the evolution of area cultivated with energy plants with rape, turnip rape, sunflower seeds and soya in the period 2007-2014, is seen that the EU-28 production increased by 1101.87/1000 ha, although this increase is followed by a further fall of production 11906.94/1000 ha in

2013, production 11556.29 /1000 ha in 2014. It can be noticed from Table 3, that the lowest values of production at 1000 ha, in the analyzed period, is registered in Ireland and Slovenia. However, both showed increases in energy production plants. It was registered in Ireland in 2007 a production of 8.18/1000 ha, reaching in 2014 to manufacture 9.44/1000 ha, registering its peak in 2012 with 17.48 production/1000 ha. Similarly, in Slovenia it was recorded the lowest values of energy production plants, with only a production increase of 0.48 /1000 ha in the period under review, from 5.74 Production/1000 ha in 2007 to 6, production 22/1000 ha in 2014.

Also from the same Table 3, it can be remarked that Romania had recorded the third highest value in energy production plants, after France and Germany. Thus, although small fluctuations recorded over the reviewed period, in Romania there was an increase in the production of energy production plants of 153.56 /1000 ha, the production 1334.08 / 1000 ha in 2007, manufacturing 1487.64 /1000 ha in 2014. Promoting biofuels of agricultural origin is, as shown in specialized studies (De Fraiture et al., 2008; De Gorter and Just, 2010; Börjesson and Tufvesson, 2011), closely dependent on the availability of land resources to be allocated and used for this purpose. Lack of surplus agricultural areas or increasing rents for agricultural land will cause an increase in price production of biofuels of agricultural origin. Also an increase in oil prices would trigger an increase in bioenergy the trend of prices by increasing production costs related to energy crops. As it emerges in some European documents (European Economic and Social Committee, 2013), reallocation and land use in the production of bioenergy consists of some potential risks determined by the arising out-changer destination farmland or by allocating them to energy crops in detriment food production, either to practice intensive agriculture. In analyzing the potential risks caused by paradigm-changer agricultural production by promoting energy crops (European Economic and Social Committee, 2013) remark following:

- Increased pressure on the agricultural sector triggered by the intensification of energy crops that cause a number of phenomena such as soil erosion or compaction sharp, excessive use of fertilizers to increase production, high water consumption;
- From meadows and pastures into arable land for energy crops and carbon absorption loss related to such structures;
- Loss of biodiversity due to intensive agricultural production fashions specific to energy crops;
- Homogenizing the rural agricultural landscape. (European Economic and Social Committee, 2013).

Evolution of energy crops in Romania. Agricultural area, prices and trade balance

One last aspect considered in this study is the analysis of the evolution of energy crops in Romania from a complex perspective, given acreage energy crops, particularly sunflowers and rapeseed, the evolution of prices of these products and the trade balance commercial related. As it was demonstrated in the literature (Andrei and Gheorghe, 2014), sunflower and rapeseed crops are generating significant revenues for farmers, generating a gross margin and profit level significant to growers. From this perspective, acreage sunflower and rapeseed have recorded a significant increase over the period. As claims (Ciubota-Rosie, 2008) biomass can be successfully recommended as an important source for the production of bioenergy in Romania, with affects not only on environmental protection but is also significantly beneficial on the economic, financial and social fields. On the other hand (Venturi and Venturi, 2003) highlights the role of sunflower crops in the production of bioenergy, identifying the three main chains of production as bio-oil production from rape, soybean or sunflower and ethanol production from cereal and sugar beet. Krasuska et al., 2010 analyzing the potential of land available for growing bioenergy says that crops of non-food crops in the EU-27 (excluding Cyprus and Malta) is estimated to have a potential of 13.2 million hectares in the current situation, which could make EU a major producer of bioenergy.

Fig. 3. *The evolution of the main energy crop agricultural area cultivation in Romania, 2007-2015*

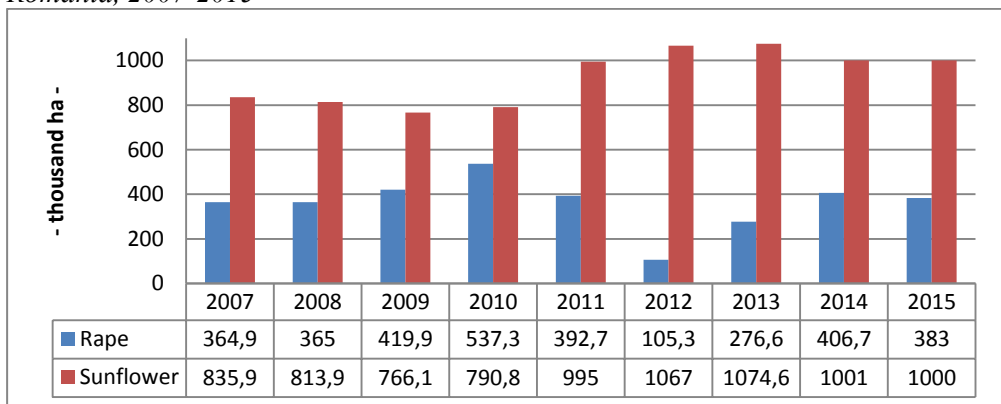

Source: *authors based on MADR, 2016a,b*

The evolution of the main energy crop agricultural area in Romania, 2007-2015 during the general trend is circumscribing to European growth areas allocated for energy crops. Increased acreage in sunflower and rape,

we can say that is carried and along amid rising prices for these products. Analyzing as gross data values, as shown in Figure 3, it can be seen throughout the entire period analyzed that for Romania, for two bioenergy crops (rape and sunflower) there is a significant increase in cultivated area, from 364.9 ha planted with rape in 2007 it reached 383.0 ha planted in 2015 and in case of sunflower from 835.9 ha in 2007 to 1,000 hectares in 2015. In Fig.4 is presented for a better understanding of the phenomenon relative evolution of the main energy crop agricultural area in Romania, 2007-2015 (2007 = 100).

Fig. 4. *Relative evolution of the main energy crop agricultural area in Romania, 2007-2015*

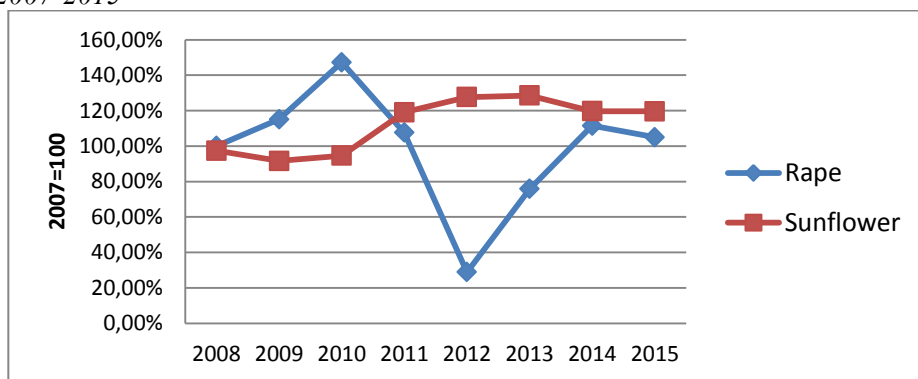

Source: *authors` own computations based on MADR, 2016a,b*

Analyzing Fig.4 it can be seen that the highest increase realized in relative terms compared to 2007, considered as a base year, are recorded in the case of sunflower 22.26%. If in the period 2008-2010 sunflower acreage decreased compared to 2007, from 2011 until the end of the reviewed period significant increases are registered. In 2013 is also registered the biggest increase of 28.56% from 2007. Compared to sunflower, the rape is at a much lower growth of only 4.93% compared to 2007. What is noteworthy is that in 2007-2011 are noted increases of rape acreage compared to 2007, registering a decline in the period 2012-2013, followed by an increase of 11.46% in 2014 and by 4.96% in 2015. From Fig.4, it can be seen a shear rape and sunflower acreage, which overlaps the evolution of instruments of financial intervention in the market and stimulating the production of agricultural biofuels. Syncope surface evolution is determined by awareness campaigns of the impacts on soil and food safety and security, given the numerous public dabates in the field. Figure 5 provides the average evolution of those two energy crops analyzed, rape and sunflower in Romania, during 2007-2015.

Fig. 5. Evolution of average production of the main energy crops agricultural area in Romania, 2007-2015

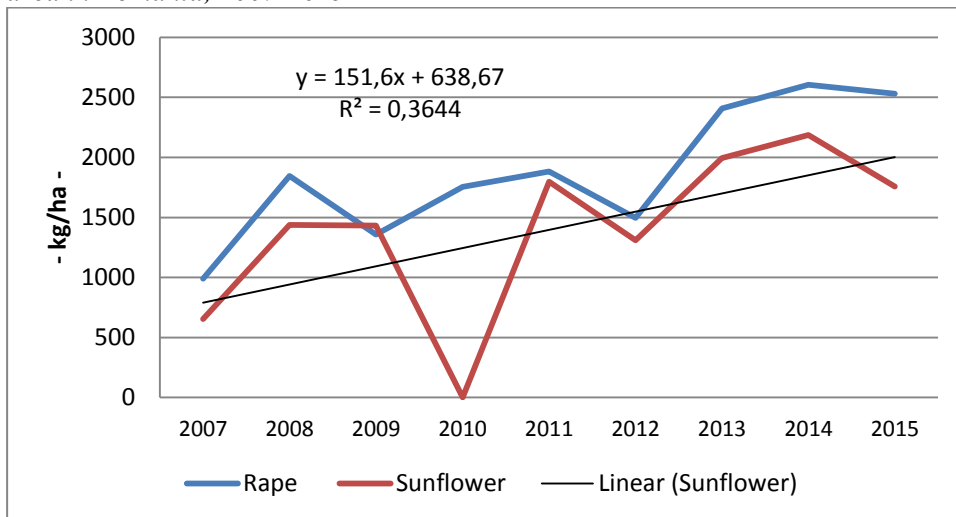

Source: authors based on MADR, 2016a,b

From Fig. 5 it can be seen an increase in average production / ha in the case of the two energy crops. Increased productivity can be a defining element in farmers tend to cultivate these plants and significant in terms of future earnings. For those two analyzed crops can be seen a tripling of yield per ha, which makes these crops a viable tool in harnessing national agricultural potential. This situation can be explained by the light of the evolution of prices. From this perspective, evolution is presented in Fig. 6 the average prices of rape and sunflower during 2007-2015 in Romania.

Fig. 6. Evolution of average prices of rape and sunflower in Romania, 2007-2015

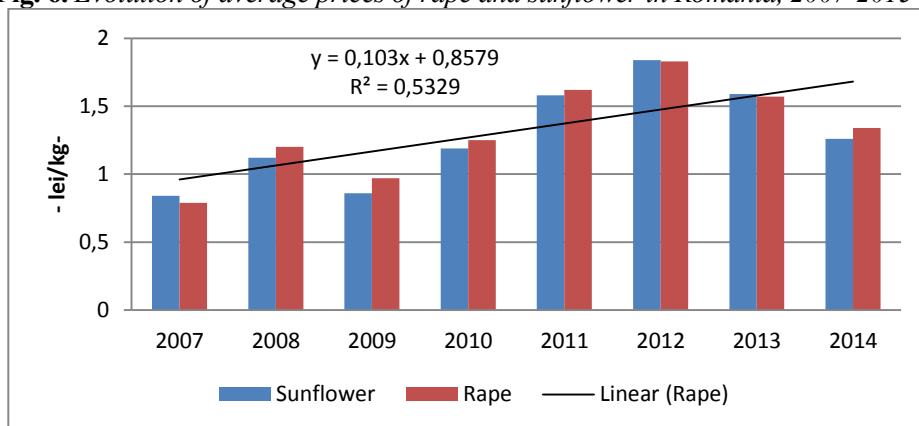

Source: authors based on MADR, 2016a,b

As can be seen from Fig.6 if evolution of average prices of rape and sunflower in Romania During 2007-2015, the trend is one of appreciation, reflecting increased interest and acquisition area of energy crops. If in 2007 the average price of sunflower was 0.84 lei / kg in 2015 which reached 1.26 lei / kg, the average increase of only 0.42 lei / kg. If rape evolution is 0.55 lei / kg, from 0.79 lei / kg in 2007 to 1.34 lei / kg in 2015. This evolution of prices can be understood and retrieved by the evolution of the trade balance in those two energy crops. In Table 4 shows the evolution of the Romanian energy balance during 2007-2015 commercial crops.

Table 4. *Romanian energy crop commercial balance, 2007-2015*

Year	Quantity IMP(to)		Quantity EXP (to)		Export /import Balance	
	Rape	Sunflower	Rape	Sunflower	Rape	Sunflower
2007	9703.6	66650.4	279125.5	382686.1	269421.9	316035.7
2008	76360.6	89576.4	564028.6	471391.2	487668	381814.8
2009	70466.9	141061.9	782186.4	564243.7	711719.5	423181.8
2010	241043.8	208284	1052366.2	557409.3	811322.4	349125.3
2011	70682.6	237374.8	577206.6	1182870.5	506524	945495.7
2012	59466.2	131205.8	68245.9	652464.1	8779.7	521258.3
2013	28841.2	93355.3	471927.1	1420169.6	443085.9	1326814.3
2014	38953	118928	989167.2	1321968.6	950214.2	1203040.6
2015	38333.5	189252.4	773494.9	1099348.7	735161.4	910096.3

Source: *authors based on MADR, 2016a,b*

The data presented in table 4 may determine the existence of a positive balance of trade balance in the case of sunflower and rape. The discreet game between import and export of rape and sunflower corrects imbalances in special light effects caused by the market. We appreciate the evolution of prices in those two products involved and the evolution of discrete volumes imported or exported. Evolution of areas planted with energy crops, at least where the two cultures analyzed in this paper, is determined by the existence and practice of the three major forms of support and incentive schemes, respectively direct payments, transitional national aid and state help for diesel used in agriculture. But the most important effects are generated by components of direct payment schemes which include the following five components (MARD 2016b):

- The single area payment scheme;
- Utiive pay ters;
- Payment for agricultural ters beneficial for the climate and the environment;
- Payment for young farmers;
- Simplified scheme for small farmers.

Given the tools mentioned above, we can say that the financial component plays an essential role in stimulating the achievement of these crops. Basically the evolution of the surfaces allocated to these crops is strictly determined by the evolution of tools and support schemes in the field. As (Ericsson et al., 2009) claims in his approach to calculate energy crop production costs in the EU, the opportunity cost of farmers selling agricultural determine the inclination of production and allocation of land to energy crops, in favor for the food production.

Conclusions

Analyzing the influence of renewable energies production of agricultural economy for the perspective on land use paradigm, agricultural prices and commerce in Romania represents an attempt to understand the figures, without understanding the influences complementary or insist on inherent transformation in the structure of the farmers' landscape agricultural areas or environmental influences. Growing energy plants caused a large national agricultural transformation paradigm.

Many farmers have used over the time, for introduction in culture, assimilated energy plants agricultural biofuels, dropping or decreasing as the case surfaces allocated for food crops. He insisted only more research on the evolution of production figures and farmland and less on agricultural paradigms. In this context it is essential in determining allocations of agricultural land for biofuel crops farmers to consider aspects such as:

- Ensuring the ecological footprint for energy crops so as to ensure sustainability of ecosystems
- Realization of land cultivation during an entire year observing crop rotation;
- Switching instruments of financial support for energy crops with demanding sustainability of agricultural landscapes;
- Implement practices that prevent depletion of organic land;

The analysis performed can be seen that if renewable energies production of agricultural economy forms a perspective on land use paradigm, agricultural prices and commerce in Romania, is synchronous with both the evolution of the European agricultural model, but especially reflects the financially support of tools' influences.

References

1. Andrei, J. V., & Popescu, G. H. (2014). Economy in Romania and the Need for Optimization of Agricultural Production Structures. *PL Acad. Research*.
2. Andrei, J.V., & Ungureanu, A. (2014). The importance of economic structure evolution in achieving performance-from agrarian economy to competitiveness in Romanian economy. *Ekonomika Poljoprivrede*, 61(4), 945.
3. Andrei, J.V., Panait, M., & Alecu, A. (2015). Transformations of European agricultural sector, market and model under the influence of Common Agricultural Policy (CAP). *Competitiveness of Agro-Food and Environmental Economy*, 137.
4. Badea, L., & Mieila, M. (2008). The economic efficiency of field crops cultivation in south Romania: trends and actions for improvement. *Annales Universitatis Apulensis Series Oeconomica*, 1(10):328-336.
5. Börjesson, P., & Tufvesson, L. M. (2011). Agricultural crop-based biofuels—resource efficiency and environmental performance including direct land use changes. *Journal of Cleaner Production*, 19(2), 108-120.
6. Chien, T., & Hu, J. L. (2007). Renewable energy and macroeconomic efficiency of OECD and non-OECD economies. *Energy Policy*, 35(7), 3606-3615.
7. Ciubota-Rosie, C., Gavrilesco, M., & Macoveanu, M. (2008). Biomass—an important renewable source of energy in Romania. *Environmental Engineering and Management Journal*, 7(5), 559-568.
8. De Fraiture, C., Giordano, M., & Liao, Y. (2008). Biofuels and implications for agricultural water use: blue impacts of green energy. *Water policy*, 10(S1), 67-81.
9. De Gorter, H., & Just, D. R. (2010). The social costs and benefits of biofuels: The intersection of environmental, energy and agricultural policy. *Applied Economic Perspectives and Policy*, 32(1), 4-32.

10. Dusmanescu, D., Andrei, J., Popescu, G. H., Nica, E., & Panait, M. (2016). Heuristic Methodology for Estimating the Liquid Biofuel Potential of a Region. *Energies*, 9(9), 703.
11. Ericsson, K., Rosenqvist, H., & Nilsson, L. J. (2009). Energy crop production costs in the EU. *Biomass and bioenergy*, 33(11), 1577-1586.
12. Krasuska, E., Cadórniga, C., Tenorio, J. L., Testa, G., & Scordia, D. (2010). Potential land availability for energy crops production in Europe. *Biofuels, Bioproducts and Biorefining*, 4(6), 658-673.
13. Lund, H. (2007). Renewable energy strategies for sustainable development. *Energy*, 32(6), 912-919.
14. Vasile, A. J., Andreea, I. R., Popescu, G. H., Elvira, N., & Marian, Z. (2016). Implications of agricultural bioenergy crop production and prices in changing the land use paradigm—the case of Romania. *Land Use Policy*, 50, 399-407.
15. Venturi, P., & Venturi, G. (2003). Analysis of energy comparison for crops in European agricultural systems. *Biomass and Bioenergy*, 25(3), 235-255.
16. Economic și Social European privind propunerea de directivă a Parlamentului European și a Consiliului privind promovarea utilizării energiei din surse regenerabile COM(2008) 19 final - 2008/0016 (COD), TEN/338 Utilizarea energiei din surse regenerabile, Bruxelles, 17 septembrie 2008.
17. Comitetul Economic și Social European,(2013), Avizul Comitetului Economic și Social European pe tema „Securitatea alimentară și bioenergia, NAT/595 Securitatea alimentară și bioenergia, Bruxelles, 18 septembrie 2013
18. European Commission (2008), Proposal for a Directive of the European Parliament and of the Council on the promotion of the use of energy from renewable sources, COM/2008/0019 final-COD 2008/0016, Brussels, 23.1.2008.

19. ***EUROSTAT (2016a), Primary production of renewable energy by type. Biodiesels, available at: <http://ec.europa.eu/eurostat/tgm/table.do?tab=table&init=1&plugin=1&language=en&pcode=ten00081>, retrieve: [20.10.2016].
20. ***EUROSTAT (2016b), Primary production of renewable energy by type. Biogasoline, available at: <http://ec.europa.eu/eurostat/tgm/table.do?tab=table&init=1&plugin=1&language=en&pcode=ten00081>, retrieve: [20.10.2016].
21. ***EUROSTAT (2016c), Share of energy from renewable sources [nrg_ind_335a], available at: http://appsso.eurostat.ec.europa.eu/nui/show.do?dataset=nrg_ind_335a&lang=en, retrieve: [20.10.2016].
22. ***EUROSTAT (2016d), Crop statistics (from 2000 onwards). Rape, turnip rape, sunflower seeds and soya, [apro_acs_a], available at: <http://appsso.eurostat.ec.europa.eu/nui/submitViewTableAction.do>, retrieve: [20.10.2016].
23. ***MADR, (2016a), Culturi de camp. Plante tehnice. Floarea soarelui. A Ministerului Agriculturii și Dezvoltării Rurale, available at: <http://www.madr.ro/culturi-de-camp/plante-tehnice/floarea-soarelui.html>, retrieve [12.09.2016].
24. ***MADR, (2016b), Culturi de camp. Plante tehnice. Rapita. Ministerului Agriculturii și Dezvoltării Rurale Available at: <http://www.madr.ro/culturi-de-camp/plante-tehnice/rapita-pentru-ulei.html>, retrieve [12.09.2016]
25. Comitetul Economic și Social European (2008), Avizul Comitetului

ROLE OF PUBLIC POLICY IN DEVELOPMENT AND APPLICATION OF CLEAN TECHNOLOGY IN THE POLISH AGRICULTURE

Barbara Wieliczko¹

Abstract

There is a need for public involvement in development and application of clean technologies in agriculture as market forces are not effective in conducting this task. The paper presents and assesses public policy instruments applied in Poland to support introduction of clean technologies. The research is based on literature review. For the analysis of the role of the public policy in development and application of agricultural innovations a division of policy instruments into two broad categories – direct and indirect policy instrument – was applied. The general conclusion is that there is still much room for improving effectiveness and efficiency of the state's involvement in environmental innovations in agriculture. The key issue is to catalyse links between farmers and other stakeholders in the innovation process.

Key words: *green and low-carbon agriculture, environmental innovation, public policy, innovation process.*

Introduction

With more and more visible climate changes making it a must to decouple economic growth from environmental impacts there is also a need to incorporate agriculture into the transition into a green economy. A key issue in this process is development and diffusion of environmental innovations mitigating adverse environmental outcomes and making more efficient use of natural resources. There are numerous policy areas that tackle different aspects of environmental issues. They are generally concentrated around environmental policy but they also include such policy areas as: research and innovation, sectoral policies (including

¹ Barbara Wieliczko, PhD, Assistant Professor, Institute of Agricultural and Food Economics – National Research Institute, Warsaw, Poland, phone: +48 22 505 4678, e-mail: Barbara.Wieliczko@ierigz.waw.pl

agricultural policy), education or fiscal policy. The role of public policy in the whole innovation process is inevitable. To be effective it must be well designed and fitted into specificity of the sectoral needs and potential. Moreover, it must offer a whole spectrum of instruments because the research conducted by Johnstone et al. suggests that “integrated approaches to environmental innovation are more likely to bring about efficiency improvements than end-of-pipe technologies” (Johnstone et al., 2016, p. 7). A careful design is also needed to avoid “unintended consequences such as favouring incumbent firms, encouraging small firms to undertake less efficient activities, or creating arbitrage and rent-seeking activity” (Neubig et al., 2016, p. 5).

Public policy is only part of the whole environment in which innovations are developed and diffused. Innovation system in agriculture is more complex than in other sectors (Factors Fostering the Effectiveness and Performance of Agricultural Research, 2016, p. 1) which is probably the result of the fact that innovations in agriculture are not developed “naturally” (Mirkowska, 2010, p. 131), that is there is hardly any research and development activity conducted by farmers which is the case in other sectors of the economy. The innovation process is shaped by three spheres that are interlinked (see fig. 1). An agricultural innovation to be diffused must have market access that can lead to adoption of this innovation and some institutional backing that can involve some financial support and/or approval of application of this newly developed innovation.

The aim of the paper is to present the role of public policy in Poland in development and application of clean technologies in the agriculture and to assess whether the current shape of public policy is optimal for transforming Polish agriculture into green and low-carbon one. Naturally the key focus is on the agricultural policy as the one that is the one the most concentrated on agricultural sector. However, also numerous other areas of public policy play a vital part in shaping conditions and incentives or disincentives for turning the agriculture into an element of green economy. In this paper the term “clean technology” is understood broadly, that is, it applies to technologies, techniques and practices that result in more efficient use of natural resources or produce less negative externalities than the ones applies so far. This understanding is similar to the broad definition of environmental innovations presented by Kemp and Pearson (2007) stating that such innovations are “the production, assimilation or exploitation of a product, production process, service or

management or business method that is novel to the organisation (developing or adopting it) and which results, throughout its life cycle, in a reduction of environmental risk, pollution and other negative impacts of resources use (including energy use) compared to relevant alternatives” (p. 7).

Figure 1. *Interlinks between innovation process and institutional, market and technical sphere*

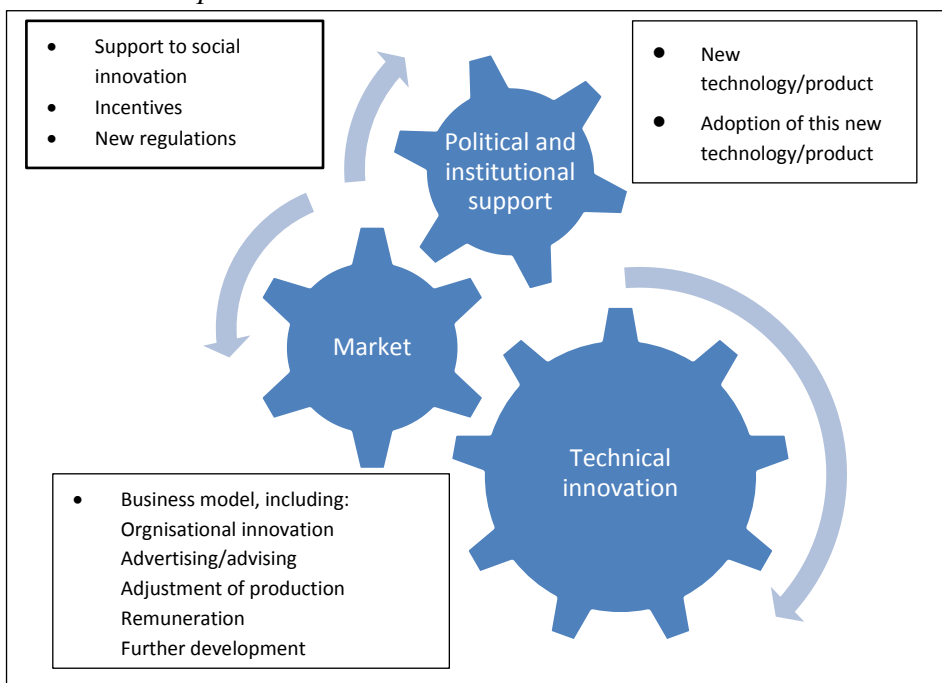

Source: *Factors Fostering the Effectiveness and Performance of Agricultural Research (2016) Impresa Policy Brief – WP3, Fig. 1.*

The impact of a given public policy on economic entities is crucial when analysing the role of policy instruments. Public policy aimed at low-carbon economy adapted to climate change can have diverse influence of strategies of economic entities that are subject to such policy. As the research related to environmental policy conducted by Mazzanti et al (2016) shows there are different paths of behaviour companies subject to a given environmental policy can adapt which leads to differences in their performance and thus in the type and scale of policy impact. Firms’ strategies towards a given public policy differ also in terms of their short- and long strategies. First of the possible strategies towards environmental policy is a defensive one. It involves development of environmental

innovations that would make the firm comply with the requirements of the new policy. This strategy can in a long-term bring not only environmental benefits but also economic ones. The second strategy is a proactive one. It is based on undertaking actions complementary to actual environmental innovations that can involve some organisational activities or human resource strategies. This strategy in a long-term can result in economic benefits. The third strategy is the mix of both defensive and proactive undertakings leading to redefinition of company's objectives. In short- and medium-term this strategy can have either both economic and environmental benefits as well as lead to a trade-off between these benefits².

Figure 2. *Policy and firm strategies in short and long period*

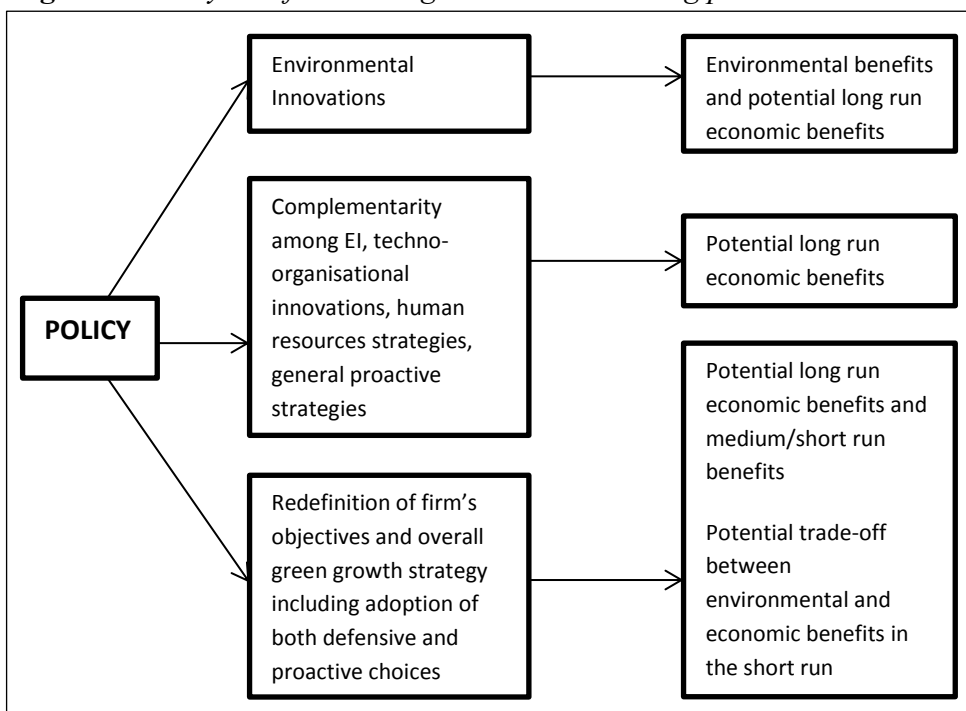

Source: *Mazzanti, et al., 2016, fig. 1.*

Naturally both development and application of innovations are extremely important, yet it seems that agricultural policy should focus on application end of the process, while closely cooperating with general research and innovation policy on the development of agriculturally and

² Naturally the results of these strategies can also be not beneficial.

environmentally useful innovations. As the research conducted by Józwiak et al. (2012) shows that the key for development of the agricultural sector in Poland is the diffusion of innovations, therefore this should be basic afford of the public policy in the case of clean technologies.

The issue of risk is vital for application of innovations. Two sets of key preconditions shaping the willingness to implement innovations can be named. The first of them is the most obvious one. It involves economic and financial conditions. The second set is less clear and less predictable. It involves behavioural predispositions.

Behavioural economics has identified some behavioural aspects that impede the adaptation process. They include, among others (Wieliczko, 2016):

- loss aversion – prescribing higher value to losses than to gains;
- risk aversion – reluctance to accept a project with higher gains but also higher risk;
- ambiguity aversion – preference for known risks over unknown risks;
- status quo bias/default bias – preference not to change anything and to select the default option where available;
- choice overload – availability of too many possible options resulting in difficulty in making a decision.

It is important to underline that the interdependencies between economic and behavioural aspects influencing decisions on adopting innovations are of complex nature and are not linear as the increase in the level of incomes is not always accompanied with the rise of propensity to introducing innovations (Józwiak et al., 2012, p. 17).

The paper is divided into sections based on the approach applied in the research presented. This approach is based on the division of the role of public policy in the innovation process into two main roles – direct and indirect. Direct role applies to two key phases in the innovation process: development of innovations and their application. Policy instruments used to have a direct impact on innovation process include, among others, fiscal incentives, grants and loans. Indirect role is played using legal regulations and instruments relating to all forms of education and information.

Direct role of public policy in development and adoption of innovations

One of the basic policy instruments for R&D and innovations are fiscal incentives. Poland does not offer much in this field for any sector of the economy. In the case of agriculture its tax system also lack incentives to undertake any investment as farmers do not pay income tax as other entrepreneurs which would allow them to reduce the taxable income by presenting investment costs in their accounts. The current tax paid by farmers does not take into account the actual situation of the farm as it is based on the size of the land owned³.

In Poland most policy tools, especially in the field related to agriculture, are based on the EU policies. In the case of facilitating co-operation and networking among stakeholder from the agri-food sector and R&D sector the only actual policy instruments are the once offered within the EU policies. Thus, their implementation has just started. Within the current Polish Rural Development Programme 2014-2020 (RDP 2014-2020) a measure “Cooperation” is introduced. The inclusion of this measure is important as the links between different stakeholders of agricultural knowledge innovation system (AKIS)⁴ are generally weak in Poland. As stated by Kania (2014) based on his research strong linkages can be identified only between extension services advisors and farmers, extension services and research as well as farmers and input sellers and purchasers of agricultural products. “Cooperation” is a new EU rural development policy instrument. This measure is aimed at supporting foundation and activities of operational groups for innovations within the European Innovation Partnership. Members of such operational groups can be farmers, research institutions, NGOs, forest owners and extension services. The supported groups are supposed to create innovations related to new products, practices, technologies, processes, methods of organisations and marketing. The maximum level of support is app. EUR 2,500 thousand with the support period of up to 3 years (Rural Development Programme 2014-2020, 2016, p. 230).

³ The issue of tax system in the Polish agriculture is presented, among other, by J. Pawłowska-Tyszko (red.) (2013), *Systemy podatkowe w krajach Unii Europejskiej*, IERiGŻ-PIB, Warszawa.

⁴ More about the concept of AKIS can be found in: EU SCAR (2012) and Floriańczyk et al. (2014).

Poland also supports process of innovation within plant production at the level of seed production and plant cultivation. For many years this support has been part of Polish agricultural policy. Yet, the actual impact on agriculture seems to be insignificant. Moreover, the level of funds allocated for these tasks have been steadily declining contributing to decreasing impact of this measures. The low of effectiveness of this aspect of the public policy is also shown by the low level of use of qualified seed material. For example, in the case of rape it is only 16% (Józwiak et al., 2012, p. 9). This part of the Polish national agricultural policy should be reshaped to make the funds more efficiently used. Possible solution for improvement is the introduction of grant system where research institutions – both public and private – could compete for funds. Yet, the system must be offer stable financing and rules of functioning.

As application of innovations we can see the implementation of the measure “Agri-environment-climate” (M10)⁵ of the RDP 2014-2020. This measure is supposed to encourage farmers to introduce agricultural practices that are beneficial to environment protection and sustainable land management. The encouragement is needed as these practices are not obligatory for farmers so to implement them farmers need to be remunerated for the cost of applying them.

Another measure of the Polish RDP 2014-2020 partially involves support for introducing clean technologies in agriculture is “Investment in fixed assets” (M04). The supported investment should be aimed at improvement of competitiveness or environmental effects. This measures includes three sub-measures. First of them envisages modernisation of farms. As stated in the RDP 2014-2020 “part of the realised operations can lead to achieving economic goals through investment related to rationalisation of the use of natural resources (such as: water, energy, use of renewable energy sources) or including different aspects of adjustment to climate change and reduction of burden to the environment” (Ministerstwo Rolnictwa i Rozwoju Wsi 2016, p. 105). Also in the case of investment in agri-food processing within one of the other sub-measure the environmental innovations are envisaged. Yet, the projects prepared

⁵ Code of the measure according to the Regulation (EU) No 1305/2013 Of The European Parliament and of the Council of 17 December 2013 on support for rural development by the European Agricultural Fund for Rural Development (EAFRD) and repealing Council Regulation (EC) No 1698/2005.

by entities applying for support will be assessed based on their planned change in the gross value added not on their impact on environment.

Indirect role of public policy in development and application of environmental innovation

There are two key elements of indirect impact of public policy on development and adaptation of innovations. First of them is introducing specific regulations forcing entities subject to them to undertake some steps to observe them or somehow evade them. Second of them is broadly understood education. It includes, among others, training, support of extension services and information activities.

Public regulation plays a crucial role in the process of application of clean technologies. It sets compulsory compliance obligations. Regulations can encompass following types of obligations: input bans, technology-based standards (equipment used), performance-based standards (example emissions levels) or liability for environmental damages. Although traditionally environmental regulations were seen as a burden impeding the level of competitiveness, they can even lead to its improvement depending on the actions of entities that have to observe these regulations (Kulawik 2016, p. 18). There are two distinctive strategies agricultural holdings can adapt faced in environmental regulations: proactive and defensive⁶. Yet, within the agriculture there is little room for far-reaching defensive activities. The key possibility is to cut investment or production. In the case of the proactive strategy the actions concentrate on rearranging the operations of the farm to comply with the new regulations. This can require application of some clean technologies. There is a number of environmental regulations that have to be taken into account by farmers on Poland. They stem from both Polish national law and the EU legislative process. In the case of the Polish law the key of them include:

- Act of 16th April 2004 on nature protection.
- Act of 10th June 2007 on fertilizers and fertilizing.
- Act of 18th December 2003 on plant protection.
- Act of 8th March 2013 on plant production products.

⁶ As mentioned before, there is also a mixed strategy, but it is not commented here for the purpose of clarity as the mixed strategy means a combination of the costs and benefits of the two presented strategies. Its actual outcome depends on the balance between the proactive and defensive choices made.

In the case of the EU regulations the most important ones relate to establishing of obligations concerning the so-called greening of direct payments and application of cross-compliance⁷. The greening of direct payments involves introduction of payments for agricultural practices beneficial for the climate and the environment. It is a new element of direct payment system introduced with the CAP reform of 2013⁸. The obligations enabling receiving green payments by the beneficiaries of direct payments include:

- crop diversification,
- maintenance of permanent grassland,
- maintenance of ecological focus areas (EFA).

Crop diversification is seen as a tool for maintaining biodiversity accompanied by benefits for soil quality. EFA is applied to strengthen farm biodiversity, while maintenance of permanent grassland is supposed to bring such environmental benefits as carbon sequestration, and protection of environmentally sensitive grassland.

Yet, these obligations are not applied homogeneously to all farmers. Subject to crop diversification are only farmers with farms larger than 10 hectares of arable land. Details of how this obligation operates in practice vary depending on the actual farm size:

- 10-30 hectares of arable land – at least two different crops⁹ and the main crop cannot occupy more than 75% of the land;
- more than 30 hectares of arable land – a minimum of three crops, the main crop cannot occupy more than 75% of the land and two main crops combined cannot occupy more than 95% of the arable land.

⁷ Examples of other binding legislation include, inter alia: Directive 2009/147/EC of the European Parliament and of the Council of 30 November 2009 on the conservation of wild birds (so-called Bird Directive); Directive 2000/60/EC of the European Parliament and of the Council of 23 October 2000 establishing a framework for Community action in the field of water policy (Water Framework Directive); Council Directive 92/43/EEC of 21 May 1992 on the conservation of natural habitats and of wild fauna and flora, as amended (Habitats Directive); Council Directive 91/676/EEC of 12 December 1991 concerning the protection of waters against pollution caused by nitrates from agricultural sources, as amended (Nitrates Directive).

⁸ The rules on implementation of greening are stipulated in the Regulation (EU) No 1307/2013 of the European Parliament and of the Council of 17 December 2013 establishing rules for direct payments to farmers under support schemes within the framework of the common agricultural policy and repealing Council Regulation (EC) No 637/2008 and Council Regulation (EC) No 73/2009.

⁹ The area of land set-aside is considered to be a land cultivated with a different crop.

However, there are farms with arable land larger than 10 ha of UAA that are exempted from the obligation to implement crop diversification. They include:

1. farms, of which more than 75% of the arable land is covered by grass or other herbaceous forage or is a set-aside or a combination of both of these categories, and the remaining area of arable land does not exceed 30 hectares;
2. farms, of which more than 50% of the arable land declared in a given year was not declared by the beneficiary in the previous year and on all arable land in a given year there are cultivated other crops than in the previous calendar year.

The obligation concerning ecological focus areas covering at least 5% of the arable land within a farm applies to farms with over 15 hectares of arable land. Exemptions from this requirement include farmers with farms where more than 75% of the arable land is grassland, other herbaceous forage, set-aside land, land used for cultivation of legumes, or a combination of these categories, and the remaining area of arable land does not exceed 30 hectares. Ecological focus areas include following landscape elements: set-aside land, elements of the landscape, buffer zones, strips of land eligible for direct payments along the borders of forests, short rotation coppice, afforested areas, intercrops and green cover, nitrogen-fixing crops.

It is only second year of functioning of the greening so it is hard to assess what long-term impact it can have on farmers' production strategies and whether it can lead to any important innovations in conducting agricultural activity. The greening is strongly criticised¹⁰ for its low environmental impact and further changes are expected to be introduced in the next reform of the common agricultural policy.

The implementation of greening in the first year of its functioning showed that under at least one greening requirement there were only 23% of farmers in Poland operating on a total of 11% of the Polish agricultural area (European Commission, 2016, tab. 2). Thus, the actual importance of this obligation can be seen as minor in terms of environmental impact. However, when we take into account the fact that these were the largest farms responsible for bulk of the Polish agricultural production some economic impact of these obligations is undeniable.

¹⁰ For example in the paper by Matthews (2016).

It must be also mentioned that both regulations themselves as well as the whole institutional setting are also important for trust building among innovation stakeholders, especially in the cooperation on development of innovations between different stakeholders. To make this cooperation work building trust is necessary. Institutions are part of this trust building as they can assure all side of their rights and possibility to seek legal solutions of the potential conflicts between sides to the cooperation agreement.

Education and promotion of environmental innovations is another aspect of indirect activities related to application of innovations in agriculture. Within this field there are also some activities conducted within the Polish public policy. First of such instruments is the measure “Knowledge transfer and information activities” (M01) implemented as part of the Polish RDP 2014-2020. This policy measure is aimed at expanding knowledge base and innovativeness in rural areas as well as strengthening links between agriculture, forestry and research. Moreover, it is to promote life-long learning. This measure includes two sub-measures:

- Support for professional training and acquiring new skills;
- Support for demonstrations and information activities.

In the case of both sub-measures direct beneficiaries can be research and educational institutions, public extension services, regional authorities, public administration bodies and other entities offering training services. Under the second sub-measure training will be offered to farmers and forest owners. They will concentrate on the issues related to conducting agricultural and forestry activities.

The second sub-measure is aimed at popularization of innovations and good practices. The key element of this instrument is the enabling the farmers to familiarize with the practical application of innovations. It is explicitly stated that demonstrations should include, among others, innovations relating to environmental protection and climate change including renewable energy sources.

The second measure of the Polish RDP 2014-2020 dealing with educational and promotional issues is the measure “Advisory services” (M02). The aim of this measure is strengthening the knowledge and innovation transfer through the use of advisory services. This measure includes two sub-measures:

- Support for users of advisory services users;
- Support for training of advisors.

Conclusions

Assessment of the role of the Polish public policy in development and application of clean technologies in the agriculture should involve specification of the actual impact on specific types of environmental innovations. Naturally, there are different ways to construct typologies of environmental innovations. Yet, for the purpose of this paper an approach presented by Kemp and Pearson (2007). They distinguish following types of environmental innovations¹¹:

1. Environmental technologies:
 - pollution control technologies including waste water treatment technologies;
 - cleaning technologies that treat pollution released into the environment;
 - cleaner process technologies: new manufacturing processes that are less polluting and/or more resource efficient than relevant alternatives;
 - waste management equipment;
 - environmental monitoring and instrumentation;
 - green energy technologies;
 - water supply;
 - noise and vibration control.
2. Organisational innovation for the environment: the introduction of organisational methods and management systems for dealing with environmental issues in production and products:
 - Pollution prevention schemes: aimed at prevention of pollution through input substitution, more efficient operation of processes and small changes to production plants;
 - Environmental management and auditing systems: formal systems of environmental management involving measurement, reporting and responsibilities for dealing with issues of material use, energy, water and waste (EMAS and ISO 14001 are examples);
 - Chain management: cooperation between companies so as to close material loops and to avoid environmental damage across the value chain.

¹¹ They use the term “eco-innovations”.

3. Product and service innovation offering environmental benefits new or environmentally improved products and environmentally beneficial services:
 - new or environmentally improved material products (goods) including eco-houses and buildings;
 - green financial products (such as eco-leases or climate mortgages);
 - environmental services: solid and hazardous waste management, water and waste water management, environmental consulting, testing and engineering, other testing and analytical services;
 - services that are less pollution and resource intensive.
4. Green system innovations – alternative systems of production and consumption that are more environmentally benign than existing systems.

The Polish public policy concerning environmental innovations in the agriculture is most active in the field of promotion and education. It seems to be the best way government can engage in the process of adopting innovations in the agriculture, a sector with numerous small entities hard to reach by new start-ups that are generally small companies offering innovation. Therefore, a well design system of constant learning process within extension services must be put in place, as well as effective knowledge diffusion system. A well-developed network of extension centres can be cited as a key strength. Although some, mostly indirect stimuli for adaptation of environmental innovations in the agriculture can be acknowledged, their range and quality are not sufficient to have a significant impact on the Polish agriculture. There is still much that can be done and should be done.

Table 1. *Role of public policy in Poland in development and adoption of clean technologies in agriculture*

Type of innovation	DIRECT		INDIRECT	
	Development of innovations	Adaptation of innovations	Regulation	Promotion and education
Environmental technologies		✓	✓	✓
Organisational innovation		✓		✓
Product and service innovation		✓		✓
Green system innovations		✓		✓

Source: *Own elaboration.*

Yet, it must be also stated that especially in the field of education and promotion of innovations private sector is increasingly active. This applies to companies offering such products. They directly operate through their sales force to inform farmers about the advantages of their products. However, this activity does not necessary in every case offer the optimal solution in terms of meeting the economic and environmental goal of both farmers and the whole society. This also leaves some room for public activities that should offer objective knowledge about the strengths and weakness of given innovations.

As it is widely accepted innovations are not only about new technologies but also about institutional change (Kilelu et al., 2013) that enables them to be created and get through becoming commonly adapted. Therefore, it is also important to assess the role of public policy in institution changes to verify whether it acts as a catalyst or a barrier to popularization of innovations. In this context it must be assessed whether public policy stimulates the process of co-innovation. Co-innovation is “the combination of collaborative, complementary and coordinated innovation” (Blitzer, Bijman, 2015, p. 2182).

Based on the analysis presented (tab. 1) it can be stated that Poland does not have a well-developed innovation policy mix. This naturally applies to the agriculture. To boost the application of clean technologies in the Polish agriculture tax incentives should be applied. Yet, the issue of introducing income tax for farmers has been too controversial for consecutive governments and in the foreseeable future we cannot expect an introduction of such tax. Thus, we also cannot expect any fiscal incentives for farmers to adapt innovative technologies. With the expected reduction of EU funds for farm investment support this can result in lower net investment the whole farming sector in Poland.

Although the involvement of the state in the promotion and education concerning adopting clean technologies in Poland can be seen as the most developed part of agricultural innovation policy mix, there is still much to be done to reinforce linkages between different participants of agricultural knowledge and innovation system (AKIS). The implementation of RDP “Cooperation” can be seen only as the first step in this process. There is still need for more research grants applying multidisciplinary attitude and involving farmers, agri-food industry and non-governmental organisations in order to develop sustainable practices. Moreover, Poland, not only in the case of agriculture, must develop tools encouraging collaboration

between public and private researchers and some forms of PPP in the field of R&D. There is one more field of activity that should be tackled by public policy. It is the problem of behavioural aspects related to application of innovations. This issue is still not much research into this field. Yet, what is already known is the fact that policy designers have to take into account the fact that the decision on adopting innovations is based not only on economic calculations but also on attitude towards taking risk under lack of full information.

The whole agricultural policy in Poland seems still not to offer a balance between supporting competitiveness and environmental issues within the agriculture. Yet, the EU policy constantly increases its demand for balancing these issues so it can be expected that it will be translated into the Polish approach and investment support will be more and more focused on taking into consideration environmental impact of planned investment projects. It seems that the role of public policy in the fields of agricultural investment is still a substitutability one with not much action undertaken by the sector itself. Hopefully, with the development of policy tools facilitating collaboration between both public and private research as well as other AKIS stakeholders the role of public policy can gradually become a complementary one. Summing up, the whole analysis of the role of public policy in the development and adoption of clean technologies in Poland we can state the recommendations concerning strengthening research and innovation policy developed as conclusions of the Impresa project can be also presented as recommendations for the improvement of the Polish public policy for clean technologies. Surely, these recommendations would be adequate also for numerous other countries. These recommendations are:

- “Integrate research and innovation support instruments: Overcome the gap between initial research and the commercialisation phase.
- Strengthen agricultural extension and advisory services as educators, knowledge hubs and innovation facilitators: Encourage researchers to get feedback from advisors (public and private); and ensure long-term perspective (essential for development of trust relationships with farmers).
- Coordinate and improve effectiveness of support instruments for capacity building, networking and funding of innovation brokers: Provision of tools for networking and brokerage; framework for interaction and networking.

- Coordinate innovation support instruments with agricultural policies: In particular with regional and Rural Development Programmes.
- Include stakeholders in research programming and evaluation: To be involved selectively and strategically in the initial phase.” (Factors Fostering the Effectiveness and Performance of Agricultural Research, 2016, p. 4).

Literature

1. Bitzer Verena, Bijman Jos (2015): *From innovation to co-innovation? An exploration of African agrifood chains*, British Food Journal vol. 117 issue 8, pp.2182-2199.
2. Council Directive 91/676/EEC of 12 December 1991 concerning the protection of waters against pollution caused by nitrates from agricultural sources (OJ EU L 375).
3. Council Directive 92/43/EEC of 21 May 1992 on the conservation of natural habitats and of wild fauna and flora (OJ EU L206).
4. Directive 2000/60/EC of the European Parliament and of the Council of 23 October 2000 establishing a framework for Community action in the field of water policy (OJ EU L327).
5. Directive 2009/147/EC of the European Parliament and of the Council of 30 November 2009 on the conservation of wild birds (OJ EU L 20).
6. European Commission (2016): *Commission Staff Working Document*:
7. *Review of greening after one year*, SWD(2016) 218 final, Part 3/6, Brussels.
8. EU SCAR (2012): *Agricultural knowledge and innovation systems in transition – a reflection paper*, Publications Office of the European Union, Brussels.
9. *Factors Fostering the Effectiveness and Performance of Agricultural Research* (2016) Impresa Policy Brief – WP3.
10. Floriańczyk Zbigniew, Szekely Erika, Fieldsend Andrew (2014): *Institutional preparations for the implementation of the European Innovation Partnership* [in:] Potori Norbert (ed.), Chmieliński Paweł

- (ed.), Fieldsend Andrew (ed.) Structural Changes in Polish and Hungarian Agriculture since EU Accession: Lessons Learned and Implications for the Design of Future Agricultural Policies, Research Institute of Agricultural Economics, Budapest.
11. Johnstone Nick, Managi Shunsuke, Cárdenas Rodríguez Miguel, Hašič Ivan, Fujii Hidemichi, Souchier Martin (2016): *Environmental Policy Design, Innovation and Efficiency Gains in Electricity Generation*, Environment Working Paper No. 104, OECD.
 12. Józwiak Wojciech, Kagan Adam, Mirkowska Zofia (2012): *Innowacje w polskich gospodarstwach rolnych, zakres ich wdrażania i znaczenie*, Zagadnienia Ekonomiki Rolnej, nr 3(332), pp.3-27.
 13. Kania Józef (2014): *System wiedzy i informacji rolniczej w rolnictwie polskim*, Research Papers of the Wrocław University of Economics, issue 360, p. 55-62.
 14. Kemp René, Pearson Peter (2007): *Final report of the MEI project measuring eco innovation*, UNU MERIT, Maastricht.
 15. Kilelu Cathrine, Klerkx Laurence, Leeuwis Cees (2013): *Unraveling the role of innovation platforms in supporting co-evolution of innovation: Contributions and tensions in a smallholder dairy development programme*, Agricultural Systems 118(0): 65-77.
 16. Kulawik Jacek (2016): *Environmental Regulations and Innovations versus Competitiveness*, Problems of Agricultural Economics, no. 1(346), pp. 3-21.
 17. Matthews Alan (2016): *The Future of Direct Payments [in:] Research For AGRI Committee – CAP Reform Post-2020 – Challenges in Agriculture*, European Parliament, Brussels.
 18. Mazzanti, Massimiliano, Antonioli Davide, Ghisetti Claudia, Nicolli Francesco (2016): *Firm Surveys relating Environmental Policies, Environmental Performance and Innovation: Design Challenges and insights from Empirical Application*, OECD Environment Working Papers, No. 103, OECD Publishing, Paris.
 19. Ministerstwo Rolnictwa i Rozwoju Wsi (2016): *Program Rozwoju Obszarów Wiejskich na lata 2014-2020 (PROW 2014-2020)*. Skrócona wersja programu, Ministerstwo Rolnictwa i Rozwoju Wsi, Warszawa.

20. Mirkowska Zofia (2010): *Innowacje i innowacyjna gospodarka a rolnictwo*, Zagadnienia Ekonomiki Rolnej, nr 4, p. 122-133.
21. Neubig Thomas, Galindo-Rueda Fernando, Appelt Silvia, Criscuolo Chiara, Bajgar Matej (2016): *Fiscal incentives for R&D and innovation in a diverse world*, OECD Taxation Working Papers, No. 27, OECD Publishing, Paris.
22. Pawłowska-Tyszko Joanna (red.) (2013): *Systemy podatkowe w krajach Unii Europejskiej*, IERiGŻ-PIB, Warszawa.
23. Regulation (EU) No 1305/2013 Of The European Parliament and of the Council of 17 December 2013 on support for rural development by the European Agricultural Fund for Rural Development (EAFRD) and repealing Council Regulation (EC) No 1698/2005, (OJ EU L 347).
24. Regulation (EU) No 1307/2013 of the European Parliament And Of The Council of 17 December 2013 establishing rules for direct payments to farmers under support schemes within the framework of the common agricultural policy and repealing Council Regulation (EC) No 637/2008 and Council Regulation (EC) No 73/2009, (OJ EU L347).
25. Ustawa z dnia 8 marca 2013 r. o środkach ochrony roślin (Dz.U. z 2013 r., poz. 455) [Act of 8th March 2013 on plant production products].
26. Ustawa z dnia 10 lipca 2007 r. o nawozach i nawożeniu [Act of th June 2007 on fertilizers and fertilizing].
27. Ustawa z dnia 16 kwietnia 2004 r. o ochronie przyrody (Dz.U. z 2013 r., poz. 627, z późn. zm.) [Act of 16th April 2004 on nature protection].
28. Ustawa z dnia 18 grudnia 2003 r. o ochronie roślin (Dz.U. z 2008 r., Nr 133, poz. 849, z późn. zm.) [Act of 18th December 2003 on plant protection].
29. Wieliczko Barbara (2016): *It is all about the risk – how to create an enabling environment for agricultural innovation within the CAP?* Presentation at the 14th European Rural Development Network, Budapest, 3-5 October 2016.

ECONOMIC EFFECTS OF THE SOLAR AND WIND ENERGY USE IN IRRIGATION OF VEGETABLE CULTURES¹

Jonel Subić², Marko Jeločnik³

Abstract

Available climate and natural resources are allowing the successful vegetable production at wider territory of the Republic of Serbia. Production lines are organized at open field or in protected areas (greenhouses), and usually involve the use of agro technical measure of irrigation. Technological-technical complexity and much higher requirements for production intensity, more often contribute to a higher competitiveness of agricultural holdings dominantly oriented to the production of vegetables. In paper are presented the comparative results of field researches carried out in September and October 2015, and during the period August - November 2016. In last research, besides mobile robotic solar generator, in real terms was partially tested the use of mobile wind generator. Also, during the research are processed the data collected from the members of family agricultural holdings focused to the vegetable production, located in the Glogonj village at territory of the Pančevo city (within the wider area of the Upper Danube Basin) and in the Veliko Selo village at the territory of the Belgrade city (within the area of the Middle Danube Basin). For the research purposes, in accordance with the previously made agreement with holdings' members, observed holdings are marked with A and B. On the holding A, in the structure of variable costs, costs of irrigation are quite an equable (in the open field: from 357,72 to 364,29 EUR/ha, or in a greenhouse: from 378,50 to 554,00 EUR/ha). On the holding B, in the structure of variable costs, depending the production area costs of irrigation are visibly different (in the open field: from 85,00 to 341,50 EUR/ha, or in a greenhouse: from 2.550,00 to 3.278,00 EUR/ha). In order to

¹ Paper is a part of the research at the project III-46006, funded by the Ministry of Education, Science and Technological Development of the Republic of Serbia, as well as project no. 680-00-0031/2016-02, funded by the Ministry of Agriculture and Environmental Protection of the Republic of Serbia.

² Jonel Subić, Ph.D., Associate Professor, Senior Research Associate, Institute of Agricultural Economics, 15 Volgina Street, 11060 Belgrade, Republic of Serbia, Phone: +381-11-697-28-58, E-mail: jonel_s@iep.bg.ac.rs

³ Marko Jeločnik, M.A., Research Assistant, Institute of Agricultural Economics, 15 Volgina Street, 11060 Belgrade, Republic of Serbia, Phone: +381-11-697-28-52, E-mail: marko_j@iep.bg.ac.rs

increase economic effects in vegetable production, there is a possibility of used energy conversion (gasoline, diesel and electric power) into the cheaper and environmentally more acceptable solution (solar and wind energy).

Key words: *economic effects, solar energy, energy of wind, vegetable production, ecology.*

Introduction

On the territory of Republic of Serbia, a relatively large number of family agricultural holdings are involved in the production of vegetables. Accordingly, the economic effects in using solar and wind energy for operation of pumping systems in the process of irrigation could be of great importance for all farmers who deal with vegetables within the production structure.

Vegetable growing is the sector of agriculture, which expect from a farmer timely and adequate technical-technological and economic decisions, adjusted to planned production results (Jeločnik et al., 2015). It is well-known that farmers have a negligible effect on selling prices, but for that reason, falling into unwanted situations can compensate by proportionally large impact on the costs control (cost price) of their products and services (Vasiljević, Subić, 2010/b).

This research refers to the extension of field activities (previously done during the period September – October 2015)⁴, which had realized in the period August – November 2016. Besides a mobile robotized electrical generator, there was also tested the work of a mobile wind power generator in real conditions. Research was also implied collecting data by interviewing members of selected family agricultural holdings (dominantly oriented to vegetable production). Surveyed holdings are specific by the applied production technology and approach in purchasing inputs and sale of manufactured vegetables. Cooperation in the implementation of field activities is continued with two holdings, located in the village Glogonj (territory of the city of Belgrade – narrow area of Middle Danube Region) and Veliko Selo (territory of the city of Belgrade - narrow area of Middle Danube Region). The research work was primarily focused to those vegetable crops in which production cycle (the process of irrigation) was already tested the mobile

⁴ In the beginning of 2015, a mobile robotized solar electric generator at the Institute „Mihajlo Pupin“ was developed, the leading national research institution in the field of information-communication technologies. It is energy efficient ecological device for the production of electrical energy by using solar energy (Subić, Jeločnik, 2016).

robotized solar electrical generator, during the years 2015 and 2016 (cabbage production in open field and tomato in protected areas – greenhouses).

Material and method of work

The assumption is that irrigation costs have the character of variable costs, and they mean the costs of fuel and lubricant (i.e. covering the costs of used energy and variable costs of irrigation system) and costs of defined compensation for irrigation. Initial expectations are to exceed the increase of variable costs by increasing the holdings' income by using irrigation. Although the irrigation costs have relatively small share in the structure of total variable costs, there was considered, from economic-ecological point of view, the possibility of used energy substitution (pump unit) with ecologically and economically acceptable alternative, energy produced from a solar electrical generator or wind power generator.

In accordance to their production structure, every agricultural holding should calculate the value of production and incurred costs (by simple, clear and easily applicable model of analysis) for every production line, whereby should be marked all lines of a higher profitability level (Jeločnik et al., 2015). Methodological simplicity and high level of practicality favours the analytical calculation based on variable costs in the process of business decision-making (Vasiljević, Subić, 2010/b), since it ensures a current economic analysis of current production, i.e. the sustainability evaluation of adopted production technology and achieved results (Subić et al., 2015).

Calculation of contribution margin (gross financial result) brings face to face the market value of realized production and the variable production costs of manufactured products in a holding. Character of variable costs in plant production (including vegetable growing) has: seed and planting material, fertilizers, pesticides, energy (fuel) and lubricants, external services of agricultural mechanization, engaged labour, packaging, etc. The contribution margin is defined as difference between total production values (value of the main product increased for value of the by-products and incentives) and the proportional variable costs (Vasiljević, Subić, 2010/a).

In vegetable production, the calculation of contribution margin can contribute to the comparison of two different lines (or phases) in vegetable production in terms of equal fixed costs, or comparison of two or more intensity levels of the same line of phase of vegetable production. Depending on utilized production areas, units of measurement adjust to every individual subject (m², are, hectare), but the obtained results of contribution margin adjust to hectares due

to make an easier comparison, whether it is about the production in open field or in a protected area.

In accordance to production specificities, decision-making in agriculture is often related to uncertainty and complex task to mitigate the risk of a potentially bad decision (Subić, 2010). Therefore, for the evaluation of production results in terms of uncertainty can be used also an analytical method of determining the critical price, critical yield and critical variable costs of some production line (values at which the contribution margin equates with zero), (Nastić et al., 2014).

All calculations were done based on the production value and variable costs realised on the actual production area in the observed holdings, and after all values were brought down to the area of 1 ha, owing to easier comparison. All variable costs and values of production were expressed in RSD and EUR.

From the methodology point of view, the calculation of these items in determined vegetable crops is identical, except in case if there are certain specificities in calculating the production values (products classification) or certain variable costs. All indicators were shown in tables, previously passing through a standard mathematically-statistical analysis, in order to accentuate in detail the arithmetical operation and the structure of calculation of contribution margin based on variable costs. As in the year before, the primary intention was to mark the amount of costs of consumed energy for the process of irrigation in the production of selected vegetable cultures, which would potentially substitute (reduce) by using renewable energy.

Considering the character of selected vegetable crops and applied technological approach in their production:

1. Comparative analytical calculations based on variable costs for selected holdings and selected vegetable crops for the years 2015 and 2016 were done,
2. In detail structure of generated variable costs is shown,
3. Critical values for every production line (price, yield and variable costs) are determined.

Theoretical and material basis is taken over from the available scientific and professional literature focused on a studied problem, and also from the in-depth interviews organized with members of selected family agricultural holdings in the villages Glogonj and Veliko Selo. Most of taken over data is directly connected to production cycles in 2015 and 2016, while some data are reflection of assessment of interviewee or generally accepted standard for

specific line of vegetable production. For justified reasons, after consultations with holding members, in research both farms are marked with A and B.

Research results with discussion

Field research (experiment), previously carried out in the year 2015, have been prolonged in 2016 in the same family agricultural holdings (villages Glogonj and Veliko Selo) and on same vegetable crops (tomato and cabbage) grown in the system with irrigation in the protected area (greenhouse) and in open field.

In the observed period, the selected family agricultural holdings haven't changed the technological approach in vegetable production. As in 2015, during the year 2016, the mobile robotized solar electrical generator has been tested (this time together with the mobile wind power generator) within the production of vegetables in the system which had included irrigation, since this system of production had significantly affected the stability and amount of realised yields. It is assumed that incomes from the cultivated vegetables sale cover all production costs, i.e. provide sufficient financial resources for payment of investments in purchase/construction of the irrigation system and making profit.

According to realised results in the *production of cabbage in open field*, along with the application of agro-technical measures of irrigation in 2015 and 2016 (*Tables 1-4*), in the holding A can be noticed:

- In both production years was realised a positive contribution margin (4,137.39 EUR/ha in 2015, i.e. 5,811.83 EUR/ha in 2016). Since the technological approach in cabbage production hasn't changed, the difference among the realized contribution margins in amount of 1,674.44 EUR/ha has been a direct consequence of yield and a final product price, as well as the price of used inputs and the exchange rate of national currency in relation to euro,
- Taking into consideration the year 2015, the realised income in the production of cabbage are 1.7 times higher than the generated variable costs of production, while in the year 2016 were 2.1 times higher,
- In the structure of variable costs, the engaged labour costs dominate in both years. Seedlings costs and machining operation costs have the significant share. There can be noticed the considerable increase in the seedlings costs share, by focusing on 2016,

- In the structure of variable costs, the costs of energy (diesel), necessary for the process of irrigation, in both observed years, have a uniform and relatively modest share (6.38%, i.e. 6.77%),
- Critical values of production (where the contribution margin equates with zero) have the following values:
 - Critical price amounts 10.43 RSD/kg, or 9.63 RSD/kg;
 - Critical yield amounts 34,238.16 kg/ha, or 29,560.08 kg/ha;
 - Critical variable costs are 1,312,500.00 RSD/ha, or 1,485,000.00 RSD/ha.

Table 1. *Baseline (cabbage production in the open field)*

Region: Continental – South Banat District (Glogonj village)	Type of soil: Good
Period: Comparison of production results from two production cycles (2015. and 2016.)	Production area: 0.56 ha
2015.: 1.00 EUR = 120.00 RSD 2016.: 1.00 EUR = 123.00 RSD	Planting density: 60 x 45 cm

Source: IAE, 2015; IAE, 2016.

Table 2. *Contribution margin in cabbage production in the open field*

Element	Quantity	UM	Price/UM (in RSD)	Total RSD/0.56 ha	Total EUR/0.56 ha	Total EUR/ha
A-1 Incomes – 2015.						
Cabbage	36,750.00	kg	-	-	-	-
I class (90%)	33,075.00	kg	20.00	661,500.00	5,512.50	-
Spoilage (10%)	3,675.00	kg	-	-	-	-
Subsidies	-	-	-	-	-	-
Total A-1				661,500.00	5,512.50	9,843.75
A-2 Incomes – 2016.						
Cabbage	37,800.00	kg	-	-	-	-
I class (92%)	34,750.00	kg	22.00	764,500.00		
Spoilage (8%)	3,050.00	kg	-	-	-	-
Subsidies	-	-	-	-	-	-
Total A-2				764,500.00	6,215.40	11,099.00
Difference (A-2 – A-1)				103,000.00	702.90	1,255.25
B-1 Variable costs – 2015.						
Total B-1				383,646.50	3,195.55	5,706.36
B-2 Variable costs – 2016.						
Total B-2				364,180.00	2,960.83	5,287.17
Difference (B-2 – B-1)				-19,466.50	-234.72	-419.19
I Contribution margin – 2015. (A-1 – B-1)				277,853.50	2,316.95	4,137.39
II Contribution margin – 2016. (A-2 – B-2)				400,320.00	3,254.57	5,811.83
III Difference (II – I)				122,466.50	937.62	1,674.44

Source: IAE, 2015; IAE, 2016.

Table 3. Structure of variable costs (VC) in cabbage production in the open field

Element	Total RSD/ha (2015.)	Share in total VC (%)	Total RSD/ha (2016.)	Share in total VC (%)
Seedlings	131,250.00	19.17	149,999.70	23.07
Fertilizers	67,767.60	9.90	68,748.40	10.56
Pesticides	26,828.40	3.92	27,232.20	4.18
Packaging material	23,571.60	3.44	25,670.10	3.95
Mechanized operations	123,700.80	18.06	132,931.00	20.44
Costs of energy (irrigation)	43,714.80	6.38	43,999.60	6.77
Engaged labour	188,216.40	27.49	185,402.80	28.51
Other costs	79,713.60	11.64	16,338.00	2.52
Variable costs (total)	684,763.20	100.00	650,321.80	100.00

Source: IAE, 2015; IAE, 2016.

Table 4. Critical values in cabbage production in the open field

Element	RSD(kg)/ha - 2015.	RSD(kg)/ha - 2016.
Expected yield (EY)	65,625.00	67,500.00
Expected price (EP)	20.00	22.00
Subsidies (S)	-	-
Variable costs (VC)	684,763.20	650,321.80
Critical price: CP = (VC - S) / EY	10.43	9.63
Critical yield: CY = (VC - S) / EP	34,238.16	29,560.08
Critical variable costs: CVC = (EY x EP) + S	1,312,500.00	1,485,000.00

Source: IAE, 2015; IAE, 2016.

From everything above mentioned results the reasonable assurance that the contribution margin has left in both years enough space to cover fixed costs and realize a positive financial result, after the coverage of variable costs. The current year, 2016, was relatively better for the observed manufacturer (family agricultural holding A).

Despite of the fact that in the variable costs structure, the costs of irrigation (used energy – diesel) have very small and uniform value (364.29 EUR/ha in 2015, i.e. 357.72 EUR/ha in 2016), point out to possibility of their additional reduction by the conversion of used energy into cheaper and ecologically more acceptable solution (solar and wind energy), which will contribute to further improvement of realized economic results in a holding.

With direct comparison of realised results in the *production of tomato in protected area (greenhouse), in the holding A*, along with the use of agro-technical irrigation measures (Tables 5-8), can be noticed:

- The production line contributes to the realisation of the positive contribution margin (10,162.50 EUR/ha in 2015, or 11,955.50 EUR/ha in 2016). The growth of the contribution margin in amount of 1,792.00 EUR/ha is primarily the consequence of increase in prices of products in green market in the year 2016,
- realized incomes were 1.2 times higher than the generated variable costs of production in 2015, i.e. 1.3 times higher than in 2016,
- Reflection of the applied technological procedure on the structure of variable costs shows the ascendancy of relatively uniform share of engaged labour costs (22.37% in 2015, or 24.32% in 2016). In both observed years, the costs of seedlings, fertilizers and utilised equipment have relatively high share,
- Although the holding uses electrical energy from the public grid as a fuel for the irrigation system, the costs of energy have a humble share in the structure of total variable costs (1.27% in 2015, i.e. 0.82% in 2016),
- achieved critical values of production (balance of values and variable costs of production) show next results:
 - Critical price amounted 26.15 RSD/kg in 2015, i.e. 29.21 RSD/kg in 2016,
 - Critical yield was ranged from 154,064.80 kg/ha in 2015 to 151,886.60 kg/ha in 2016;
 - Critical variable costs were amounted 6,790,000.00 RSD/ha in 2015, or 7,312,500.00 RSD/ha in 2016.

Table 5. *Baseline (tomatoes production in greenhouse)*

Region: Continental – South Banat District (Glogonj village)	Type of soil: Good
Period: Comparison of production results from two 5 months production cycles (2015. and 2016.)	Size of greenhouse: 200 m ²
2015.: 1.00 EUR = 120.00 RSD 2016.: 1.00 EUR = 123.00 RSD	Planting density: 2.5 plants per m ² (4 rows x 35m)

Source: *IAE, 2015; IAE, 2016.*

Table 6. Contribution margin in tomatoes production in greenhouse

Element	Quantity	UM	Price per UM (in RSD)	Total RSD/ 200 m ²	Total EUR/ 200 m ²	Total EUR/ha
A-1 Incomes – 2015.						
Tomatoes	4,000.00	kg	-	-	-	-
I class (75%)	3,000.00	kg	35.00	105,000.00	875.00	-
II class (20%)	800.00	kg	30.00	24,000.00	200.00	-
Spoilage(5%)	200.00	kg	-	-	-	-
Subsidies	-	-	-	-	-	-
Total A-1				129,000.00	1,075.00	53,750.00
A-2 Incomes – 2016.						
Tomatoes	3,900.00	kg	-	-	-	-
I class (70%)	2,730.00	kg	40.00	109,200.00	887.80	
II class (25%)	975.00	kg	35.00	34,125.00	277.44	
Spoilage(5%)	195.00	kg	-	-	-	-
Subsidies	-	-	-	-	-	-
Total A-2				143,325.00	1,165.24	58,262.00
Difference (A-2 – A-1)				14,325.00	90.24	4,512.00
B-1 Variable costs – 2015.						
Total B-1				104,607.68	871.75	43,587.50
B-2 Variable costs – 2016.						
Total B-2				113,915.21	926.14	46,307.50
Difference (B-2 – B-1)				9,307.53	54.39	2,719.00
I Contribution margin – 2015. (A-1 – B-1)				24,392.32	203.25	10,162.50
II Contribution margin – 2016. (A-2 – B-2)				29,409.79	239.10	11,955.50
III Difference (II – I)				5,017.47	35.85	1,792.00

Source: IAE, 2015; IAE, 2016.

Table 7. Structure of variable costs (VC) in tomatoes production in greenhouse

Element	Total RSD/ha (2015.)	Share in total VC (%)	Total RSD/ha (2016.)	Share in total VC (%)
Seedlings	874,980.00	16.73	937,499.85	16.46
Fertilizers	844,980.00	16.15	874,999.86	15.36
Pesticides	232,800.00	4.45	237,499.47	4.17
Packaging material	300,000.00	5.73	350,000.19	6.14
Mechanized operations	400,020.00	7.65	492,500.61	8.65
Equipment	948,660.00	18.14	956,748.12	16.80
Costs of energy (irrigation)	66,480.00	1.27	46,555.50	0.82
Engaged labour	1,170,060.00	22.37	1,384,998.45	24.32
Other costs	392,520.00	7.51	414,946.65	7.28
Variable costs (total)	5,230,500.00	100.00	5,695,748.70	100.00

Source: IAE, 2015; IAE, 2016.

Table 8. *Critical values in tomatoes production in greenhouse*

Element	RSD(kg)/ha - 2015.	RSD(kg)/ha - 2016.
Expected yield (EY)	200,000.00	195,000.00
Expected price (EP)	33.95	37.50
Subsidies (S)	-	-
Variable costs (VC)	5,230,500.00	5,695,748.70
Critical price: $CP = (VC - S) / EY$	26.15	29.21
Critical yield: $CY = (VC - S) / EP$	154,064.80	151,886.60
Critical variable costs: $CVC = (EY \times EP) + S$	6,790,000.00	7,312,500.00

Source: IAE, 2015; IAE, 2016.

The amount of achieved contribution margins in the production of tomato in protected area (greenhouse), in the holding A, provides a significant financial reserve for the coverage of fixed costs and making profit.

Similar to the prior production line, although the costs of irrigation (used power generating energy is electrical energy from the public grid) have relatively low share in the structure of variable costs, absolutely expressed (554.00 EUR/ha in 2015, i.e. 378.50 EUR/ha in 2016) leave enough space for finding cheaper and environmentally cleaner alternatives (such as the use of renewable energy).

According to the achieved results in the family agricultural holding B, the *production of tomato in greenhouse* with the use of agro technical measures of irrigation in 2015 and 2016 (Tables 9-12), can be noticed:

- In both production years was achieved the positive contribution margin (8,450.26 EUR/ha (in 2015), i.e. 5,895.41 EUR/ha (in 2016). Since technological approach in the production of tomato hasn't been changed, the difference among the achieved contribution margins in amount of 2,554.85 EUR/ha has been a direct consequence of decrease in yield, changes in prices of used inputs and exchange rate of a national currency in relation to euro. As the holding has long-term contracted production of tomato for a known buyer, it wasn't possible to take advantage of the growth in price of final product in the year 2016,
- achieved incomes in the production of tomato are 1.25 times higher than the generated variable costs of production in 2015, i.e. 1.16 times higher than in 2016,
- The costs of engaged labour (36.48%, i.e. 39.15%) dominate in the structure of variable costs in both observed years. The costs of seedlings and equipment also have a high share,
- in the structure of total variable costs, the costs of energy (petrol), necessary for the process of irrigation (drop irrigation) take part with 7.31% (in 2015), i.e. with 9.05% (in 2016). Type and condition of an irrigation pump, number and duration of an irrigation cycle, as well as a price of used energy have affected their amount,
- critical production values, in which the contribution margin equates zero, reflect the following status:
 - Critical price of tomato was amounted 22.34 RSD/kg in 2015, or 24.07 RSD/ha in 2016;
 - Critical yield was amounted 143,391.74 kg/ha in 2015, i.e. 152,460.16 kg/ha in 2016;
 - Critical variable costs were amounted 5,476,875.00 RSD/ha in 2015, i.e. 5,403,850.00 RSD/ha in 2016.

Table 9. *Baseline (tomatoes production in greenhouse)*

Region: Continental - Belgrade (Veliko selo)	Type of soil: Good
Period: Comparison of production results from two 5 months production cycles (2015. and 2016.)	Size of greenhouse: 500 m ² (10 x50m)
2015.: 1.00 EUR = 120.00 RSD 2016.: 1.00 EUR = 123.00 RSD	Planting density: 2.5 plants per m ² (12 rows x 50m)

Source: *IAE, 2015; IAE, 2016.*

Table 10. Contribution margin in tomatoes production in greenhouse

Element	Quantity	UM	Price per UM (in RSD)	Total RSD/500 m ²	Total EUR/500 m ²	Total EUR/ha
A-1 Incomes – 2015.						
Tomatoes	9,375.00	kg	-	-	-	-
I class (80%)	7,500.00	kg	30.00	225,000.00	1,875.00	-
II class (15%)	1,405.00	kg	25.00	35,125.00	292.70	-
Spoilage (5%)	470.00	kg	-	-	-	-
Subsidies	-	-	-	-	-	-
Total A-1				260,125.00	2,167.70	43,354.20
A-2 Incomes – 2016.						
Tomatoes	9,250.00	kg	-	-	-	-
I class (85%)	7,860.00	kg	30.00	235,800.00	1,917.10	-
II class (10%)	925.00	kg	25.00	23,125.00	188.00	-
Spoilage (5%)	465.00	kg	-	-	-	-
Subsidies	-	-	-	-	-	-
Total A-2				258,925.00	2,105.10	42,101.60
Difference (A-2 – A-1)				-1,200.00	-62.60	-1,252.60
B-1 Variable costs – 2015.						
Total B-1				209,422.70	1,745.20	34,903.94
B-2 Variable costs – 2016.						
Total B-2				222,593.30	1,810.32	36,206.19
Difference (B-2 – B-1)				13,170.60	65.12	1,302.25
I Contribution margin – 2015. (A-1 – B-1)				50,702.30	422.50	8,450.26
II Contribution margin – 2016. (A-2 – B-2)				36,331.70	294.78	5,895.41
Difference (II – I)				-14,370.60	-127.72	-2,554.85

Source: IAE, 2015; IAE, 2016.

Table 11. Structure of variable costs (VC) in tomatoes production in greenhouse

Element	Total RSD/ha (2015.)	Share in total VC (%)	Total RSD/ha (2016.)	Share in total VC (%)
Seedlings	1,000,000.80	23.87	937,499.80	21.05
Fertilizers	130,728.00	3.12	134,999.90	3.03
Pesticides	197,280.00	4.71	201,000.50	4.51
Packaging material	60,000.00	1.43	61,500.00	1.38
Mechanized operations	123,408.00	2.95	124,498.10	2.80
Equipment	820,080.00	19.58	823,669.50	18.49
Costs of energy (irrigation)	306,000.00	7.31	403,194.00	9.05
Engaged labour	1,527,984.00	36.48	1,742,999.80	39.15
Other costs	22,992.00	0.55	23,999.80	0.54
Variable costs (total)	4,188,472.80	100.00	4,453,361.40	100.00

Source: IAE, 2015; IAE, 2016.

Table 12. Critical values in tomatoes production in greenhouse

Element	RSD(kg)/ha - 2015.	RSD(kg)/ha - 2016.
Expected yield (EY)	187,500.00	185,000.00
Expected price (EP)	29.21	29.21
Subsidies (S)	-	-
Variable costs (VC)	4,188,472.80	4,453,361.40
Critical price: CP = (VC - S) / EY	22.34	24.07
Critical yield: CY = (VC - S) / EP	143,391.74	152,460.16
Critical variable costs: CVC = (EY x EP) + S	5,476,875.00	5,403,850.00

Source: IAE, 2015; IAE, 2016.

The realized contribution margins in the production of tomato in greenhouse should be sufficient, in both years, for covering fixed costs and positive business operations. The costs of irrigation (consumed energy – petrol) have, as relatively high share in the structure of variable costs, as well as absolutely high amount (2,550.00 EUR/ha in 2015, i.e. 3,278.00 EUR/ha in 2016). Accordingly, with high probability, a holding could make a higher profit, if it performs an energy transfer towards ecologically and cost-friendly alternative (wind and solar energy).

Presented results in the *production of cabbage in open field*, along with the use of agro-technical measures of irrigation, in the holding B, in 2015 and 2016 (Tables 13-16), point out to:

- In both observed years, the holding was realised the positive contribution margin in amount of 6,349.73 EUR/ha in 2015, or 7,493.95 EUR/ha in 2016. The difference of 1,144.22 EUR/ha is primary the consequence of better price of cabbage in 2016;
- Realised incomes in the production of cabbage are 2.65 times (in the year 2015) i.e. 2.75 times (in 2016) higher than the incurred variable costs of production,
- Costs of engaged labour (33.72% in 2015, i.e. 34.59%) dominate in the structure of variable costs. The costs of seedlings are also pretty high,
- costs of energy (diesel fuel), necessary for the process of irrigation (sprinklers), have a significant share in the structure of variable costs (2.25% in 2015, i.e. 7.93% in 2016);
- Critical values of production, the values in which make equal total value and total variable costs, point out to the following results:
 - Critical price amounts 6.04 RSD/kg in 2015, or 7.06 RSD/kg in 2016;

- Critical yield amounts 25,168.50 kg/ha in 2015, i.e. 24,627.70 kg/ha in 2016;
- Critical variable costs amount 1,350,000.00 RSD/ha in 2015, i.e. 1,612,500.00 RSD/ha in 2016.

Table 13. *Baseline (cabbage production in the open field)*

Region: Continental – Belgrade (Veliko selo)	Type of soil: Good
Period: Comparison of production results from two production cycles (2015. and 2016.)	Production area: 80 are (2015.) and 16 are (2016.)
2015.: 1.00 EUR = 120.00 RSD 2016.: 1.00 EUR = 123.00 RSD	Planting density: 60 x 45 cm

Source: IAE, 2015; IAE, 2016.

Table 14. *Contribution margin in cabbage production in the open field*

Element	Quantity	UM	Price per UM (in RSD)	Total RSD/80 are	Total EUR/80 are	Total EUR/ha
A-1 Incomes – 2015.						
Cabbage	60,000.00	kg	-	-	-	-
I class (90%)	54,000.00	kg	18.00	972,000.00	8,100.00	-
Spoilage(10%)	6,000.00	kg	-	-	-	-
Subsidies	-	-	-	-	-	-
Total A-1				972,000.00	8,100.00	10,125.00
B-1 Variable costs – 2015.						
Total B-1				362,425.20	3,020.21	3,775.27
I Contribution margin – 2015. (A-1 – B-1)				609,574.80	5,079.79	6,349.73
Element	Quantity	UM	Price per UM (in RSD)	Total RSD/16 are	Total EUR/16 are	Total EUR/ha
A-2 Incomes – 2016.						
Cabbage	12,000.00	kg	-	-	-	-
I class (90%)	10,800.00	kg	21.50	232,200.00	1,887.80	-
Spoilage(10%)	1,200.00	kg	-	-	-	-
Subsidies	-	-	-	-	-	-
Total A-2				232,200.00	1,887.80	11,798.80
B-1 Variable costs – 2016.						
Total B-2				84,715.00	688.78	4,304.85
II Contribution margin – 2016. (A-2 – B-2)				147,485.00	1,199.02	7,493.95
Difference (A-2 – A-1)						1,673.80
Difference (B-2 – B-1)						529.58
III Difference (II – I)						1,144.22

Source: IAE, 2015; IAE, 2016.

Table 15. *Structure of variable costs (VC) in cabbage production in the open field*

Element	Total RSD/ha (2015.)	Share in total VC (%)	Total RSD/ha (2016.)	Share in total VC (%)
Seedlings	131,250.00	28.97	140,625.90	26.56
Fertilizers	65,650.80	14.49	67,188.80	12.69
Pesticides	28,320.00	6.25	29,064.90	5.49
Mechanized operations	62,550.00	13.81	65,288.40	12.33
Costs of energy (irrigation)	10,200.00	2.25	42,004.50	7.93
Engaged labour	152,749.20	33.72	183,134.70	34.59
Other costs	2,312.40	0.51	2,189.40	0.41
Variable costs (total)	453,032.40	100.00	529,496.60	100.00

Source: IAE, 2015; IAE, 2016.

Table 16. *Critical values in cabbage production in the open field*

Element	RSD(kg)/ha - 2015.	RSD(kg)/ha - 2016.
Expected yield (EY)	75,000.00	75,000.00
Expected price (EP)	18.00	21.50
Subsidies (S)	-	-
Variable costs (VC)	453,032.40	529,496.60
Critical price: CP = (VC - S) / EY	6.04	7.06
Critical yield: CY = (VC - S) / EP	25,168.50	24,627.70
Critical variable costs: CVC = (EY x EP) + S	1,350,000.00	1,612,500.00

Source: IAE, 2015; IAE, 2016.

The amount of realized contribution margins in the production of cabbage in the holding B, in both years, should cover the fixed costs and the realization of positive financial result (profit). Costs of energy used during the process of irrigation (diesel fuel), expressed per hectare of production area, differ significantly in the observed years (85.00 EUR/ha in 2015, i.e. 341.50 EUR/ha in 2016), which is predominantly the consequence of a type, power and condition of used generators for running the irrigation system, number and duration of an irrigation cycle, as well as a price of used energy. Potential conversion of used energy by the environmentally preferable alternative (solar and wind energy), would surely reflect to higher profitability of a described production line.

Conclusion

Energy demand of large number of activities within modern, multifunctional agriculture can be satisfied by renewable energy (such as solar and wind energy), which could replace widely used fossil fuels. Goals defined by project

„Socio-economic and ecological aspects of RE application in agricultural production of the Republic of Serbia” are in accordance with the entire actual national legislation regarding promotion and support of increasing use of RE in the sector of agriculture.

Vegetable growing in open space or within a protected area, from the aspect of technological competitiveness, must satisfy basic conditions of profitability and food safety. On the other hand, considering the pressure of climate change in our production conditions, modern vegetable production requires application of agro-technical measures such as irrigation (sprinkler systems and drop irrigation prevail) where there is a general practice to apply irrigation as a basic production measure.

Analysis of field testing results of a mobile robotic solar electrical generator and a mobile wind generator in vegetable production (cabbage and tomato) in open space and within the protected area at agricultural farms in villages Glogonj and Veliko Selo during 2015 and 2016, with simultaneously applied irrigation of crops, showed positive results in the observed vegetable production lines, based on the contribution margin calculation.

It is noticeable that in the structure of variable costs, the costs of irrigation, i.e. the costs of consumed energy (diesel fuel, petrol or electricity) depending on a type, power and condition of power generating unit, frequency and length of a cycle of irrigation and used energy, have relatively low/modest share:

- *For electrical energy* from 0.8% to 1.3%,
- *For petrol* from 7.3% to 9%,
- *For diesel* from 2.3% to 7.9%.

On the other hand, an absolutely expressed value of these costs per hectare of production area under vegetable crops was ranged:

- *For electrical energy* from 379 to 554 EUR;
- *For petrol* from 2,550 to 3,280 EUR;
- *For diesel* from 85 to 364 EUR.

Everything above shown indicates that some farms in certain vegetable production lines must find cheaper (needless dissipation of inputs) and ecologically more acceptable solutions, such as solar energy (mobile robotic solar electric generator) or wind energy (mobile wind generator).

Analysis of the research results indicates that, during moderate irrigation, the mobile robotic solar electric generator (basic or improved types of devices) or mobile wind generator are several times more cost-effective and ecologically very acceptable. Limitation can be the operations autonomy of devices:

- *for basic version of the mobile robotic solar electric generator* (mono-phase device with maximum power of 3 KW) about 2 working hours (with battery discharge till the level of repletion 30%);
- *for improved version of the mobile robotic solar electric generator* (three-phase device with frequent regulator of 4 KW maximum power and stronger batteries) about 4 working hours (with battery discharge till the level of repletion 30-40%);
- *for mobile wind generator* (power of around 1,5 KW) about 4 working hours.

This means that, in all possible cases, in spite of cheap energy, it is possible to irrigate daily up to $\frac{1}{4}$ hectares (25 are) of production area, after which work of device depends on connecting to the electrical network or by mutual complementing of solar or wind energy devices.

On the other hand, one can assume the following:

a) *Holding disposes with 1 or 2ha of production area under vegetables* (open field and green house) with the possibility of organizing two production cycles of a vegetable culture during one year (spring and summer planting); Average collective costs for all production lines and irrigation systems for one production cycle was about 988 EUR (approximately 1,000 EUR). The Ministry of Agriculture and Environmental Protection gives incentives for agricultural mechanization and equipment in amount of 40% of their purchasing value (50% in marginal regions). Lifetime of a device is minimum 20 years which is guaranteed by the production specification.

b) *For basic version of robotic solar electric generator*, expected price of device for basic package would be about 7,000 EUR (i.e. 4.200 EUR with incentives of 40%). So, it can be reliably said that investment return, through energy savings, could be slightly above two exploitation years (if it would operate on large farms with 2 ha of production areas or in the case of two production cycles of vegetables during one calendar year).

v) *For the improved version of the mobile robotic solar electric generator*, the estimated price of the device would be about 10,000 EUR (i.e. 6,000 EUR with incentives of 40%). So, one can reliably said that investment return of this device type, through energy savings, would be in three years of exploitation (if it would operate on large farms with 2 ha of production areas or in the case of two production cycles of vegetables during one calendar year).

g) *For the mobile wind generator*, the estimated price of device would be about 3,000 EUR (i.e. 1,800 EUR with incentives of 40%). So, it can be

reliably said that investment return of this device, through energy savings, in the best case scenario, would be slightly more than one year of exploitation of the device (if it would operate on large farms with 2 ha of production areas or in the case of two production cycles of vegetables during one calendar year).

d) *Symbiosis of the improved version of the mobile robotic solar electrical generator and the mobile wind generator* is offered as the most advisable solution, with estimated price of the device of 12,600 EUR (i.e. 7,560 EUR with subventions of 40%). So, with high reliability, one can expect investment return, through energy savings, in the best case scenario, for incomplete four years of exploitation of the device (if it would operate on large farms with 2 ha of production areas or in the case of two production cycles of vegetables during one calendar year).

Literature

1. IAE (2015): *Set of data needed for development of the contribution margin in vegetable production*, internal documentation, field research data related to the project: Techno-economic aspects of renewable energy and mobile robotic solar electric generators use in agriculture, Institute of agricultural economics, Belgrade.
2. IAE (2016): *Set of data needed for development of the contribution margin in vegetable production*, internal documentation, field research data related to the project: Socio-economic and ecological aspects of RES in agricultural production of Republic of Serbia, Institute of agricultural economics, Belgrade.
3. Jeločnik, M., Nastić, L., Subić, J. (2015): *Analiza pokrića varijabilnih troškova u proizvodnji šećerne repe*, Zbornik naučnih radova Instituta PKB Agroekonomik, vol. 21, br. 1-2, str. 201-208.
4. Nastić, L., Jeločnik, M., Subić, J. (2014): *Analysis of calla lily and cucumber production in greenhouse*, Ekonomika Niš, vol. 60, br. 4, pp. 209-217.
5. Subić Jonel, Jeločnik Marko (2016): *Economic effects of new technologies application in vegetable production*, invited paper, in: Proceedings of 152nd EAAE Seminar: Emerging technologies and the development of agriculture, SAAE, Belgrade, IAE, Belgrade, Faculty of Economics, University of Subotica, Serbia, pp. 15-35.
6. Subić, J. (2010): *Specifičnosti procesa investiranja u poljoprivredi*, Monografija, Institut za ekonomiku poljoprivrede, Beograd.

7. Subić, J., Jeločnik, M., Zubović, J. (2015): *Primena navodnjavanja kao agrotehničke mere - analiza marže pokrića u proizvodnji kukuruza*, *Ecologica*, vol. 22, br. 78, str. 245-251.
8. Subić, J., Vasiljević, Z., Rajić, Z. (2010): *Ekonomska analiza poslovanja poljoprivrednog gazdinstva*, *Agroznanje*, vol. 11, br. 2, str. 121-132.
9. Vasiljević, Z., Subić, J. (2010/a): *Upravljanje troškovima u agroprivredi Srbije – činilac povećanja konkurentnosti*, Predavanje po pozivu, Tematski zbornik *Agroprivreda Srbije i evropske integracije – (ne)prilagođenost obostranoj primeni Prelaznog trgovinskog sporazuma*, DAES, Beograd, str. 77-94.
10. Vasiljević, Z., Subić, J. (2010/b): *Importance of the costs calculation at the family farms in Serbia*, Chapter V, International Monograph „Agriculture in late transition – Experience of Serbia“, AAES (DAES), Belgrade, pp. 123-138.
11. Zadrudni savez Vojvodine (2013): *Cenovnik mašinskih usluga 2013*, ZSV, Novi Sad.

NITRATE PERSISTENCE IN FERRARA (IT) AGRICULTURAL LANDS, PAST ACHIEVEMENTS AND NEW PERSPECTIVES

Nicolò Colombani, Giuseppe Castaldelli¹

Abstract

This study focuses on the factors affecting nitrate removal and persistence in agricultural soils and shallow groundwater. In particular, the quantity and quality of dissolved organic carbon was assessed as possible electron donor for heterotrophic denitrification. To assess the relationship among dissolved organic carbon, nitrate and low molecular weight organic acids (acetate and formate), grids of ceramic suction cups and soil cores were established in two representative and contrasting soil types of the lower Po River floodplain. By comparing dissolved organic carbon and acetate versus nitrate concentration revealed that acetate can be used as a better proxy for denitrification in the field with respect to dissolved organic carbon. In addition, numerical simulations using HYDRUS-1D allowed to quantify the water fluxes and nitrate disappearance and persistence at both sites. Following these results, a new project will monitor the addition of organic carbon supplied by urban compost combined with minimum tillage techniques.

Key words: *denitrification, soil organic matter, compost, minimum tillage, field monitoring.*

Introduction

The recent international concern about the adverse effects of fertilizer-derived nitrate (NO_3^-) on environmental quality and public health has newly drawn attention to the research on the mechanisms and factors promoting NO_3^- removal via denitrification in agricultural soils (Galloway et al. 2008; Barnes and Raymond 2010; Castaldelli et al. 2013). In agricultural soils and aquifers, the organic matter availability for

¹ Dr. Nicolò Colombani, Research Institute for Hydrogeological Protection, National Research Council. Tel. +393291131785, E-mail: clo@unife.it
Prof. Giuseppe Castaldelli, Dept. of Biology and Evolution, University of Ferrara. Tel. +390532455737, E-mail: ctg@unife.it

denitrifying bacteria that use organic carbon as the electron donor has been identified as the most important factor limiting denitrification (Rivett et al. 2008). In most of the studies, the rate of denitrification is related to dissolved organic carbon (DOC) concentrations rather than the amount of total organic carbon and this has been motivated in reason of the higher biodegradability of the low molecular weight organic acids (LMWOA) which may account for a significant portion of DOC.

In agricultural soils cultivated with maize the incorporation of crop residues is a traditional farming practice for enhancing soil nutrient availability and productivity (Spedding et al. 2004). In soils receiving synthetic fertilizers, the annual crop residues are often the only input of organic carbon (C_{org}), buried within the top soil and slowly converted into monomers by the soil microbial community (van de Perk 2006). At present, two main synergic causes are responsible for nitrogen pollution: the large surplus of this element, particularly in highly productive agricultural areas (Thompson et al., 2007); and the simplification of the landscape, which makes nitrogenous species, in particular nitrate, even more mobile among compartments (Aschonitis et al., 2012). Intensive agricultural systems and improper agricultural practices are usually regarded as the major source of nitrate pollution (Rivett et al. 2008; Aschonitis et al., 2016).

Excessive application of nitrogen fertilizers has been demonstrated to have the potential to pollute not only soil but also groundwater (Mastrocicco et al., 2009). In order to counteract the degradation of water quality, efforts to reduce loading from watersheds are ongoing through the definition of best management practices (BMP) in agriculture (Ashonitis et al. 2013). Regulations have not become fully effective yet, partly due to the high intrinsic complexity of a soil matrix and furthermore for site specificity, which is determined by several terms as climate, cropping, fertilization type and timing. A basic example is given by the difficulty to discriminate between the relative contribution of leaching and the surface runoff, on the loss of nutrients from agricultural land (Böhlke et al., 2002; Mastrocicco et al., 2012). LMWOA, like acetate and formate, originate from plant litter breakdown, root exudation and C_{org} decomposition in anaerobic micropores of agricultural soils and can be used further by soil microbes as a C_{org} source when oxic conditions prevail (van Hees et al. 2003). In fact, they are converted to carbon dioxide or methane after a short residence time, but can also accumulate because of absorption to clay minerals and hydroxides (Strobel 2001).

Laboratory experiments have demonstrated that 70% of glucose is degraded in soluble metabolites, where acetate is the most important early LMWOA (Kusel and Drake 1995). Acetate, undergoes a rapid turnover, which can also be linked to denitrification when electron acceptors like NO_3^- are present and sub-oxic conditions prevail (Blume et al. 2002). Thus, the flux of DOC is usually considered a limiting factor for denitrification (Taylor and Townsend 2010).

NO_3^- concentrations are frequently found spatially and temporally variable in aquifers (Böhlke et al., 2002; Mastrocicco et al., 2011a), this is usually related to variations in groundwater flow direction and nitrate attenuation (Mastrocicco et al., 2011b). In Italy, the Po River valley is the largest and more intensively farmed alluvial plain and is heavily impacted by NO_3^- groundwater contamination (Mastrocicco et al., 2011a; Onorati et al., 2006; Cinnirella et al., 2005).

However, in agricultural practices, the types of soils and soil tillage, different crops and irrigation techniques and different nitrogen fertilizers, form a variety of terms emphasizing site specificity of nitrogen load and subsequent denitrification (Mastrocicco et al., 2011c;). A generally well understood and quantified process of nitrogen attenuation from surface and groundwater systems is the heterotrophic denitrification, this process uses NO_3^- as electron acceptor and a carbon source as electron donor, producing nitrogen gases (Coyne, 2008; Mastrocicco et al., 2011c). Moreover, soil compaction due to heavy machine loads tend to reduce the soil permeability and increase soil compaction (Aschonitis et al., 2015), which in turn affects the water percolation rates (Mastrocicco et al., 2010). Thus, to minimize soil carbon losses and improve denitrification new practices are still needed, such as the combination of minimum tillage and compost amendments.

The purpose of this research was to investigate the fluxes of NO_3^- from the top soil to the groundwater in cultivated plots and to determine if the soil organic carbon was able to diminish the NO_3^- concentration in shallow groundwater bodies. This was tested in two different sites with the same fertilization rates but with different soil textures, sandy and silty loamy. Following the results gained by long term experience of the fields, a new project has been established to monitor the addition of organic carbon supplied by urban compost combined with minimum tillage techniques.

Materials and methods

Field sites

The entire Po delta area is an intensively farmed region due to its flat topography and abundance of surface water for irrigation; the primary agricultural land use is maize cropping. In the study area, located in Ferrara province (Italy) at an altitude ranging from 5.0 to -3.0 m above sea level (a.s.l.), two sites (named CCR and MON) were selected to monitor the water and nitrogen transport in the unsaturated/saturated zone. Both the sites are cultivated under a rotation of cereals, mainly maize and wheat, using urea as nitrogen fertilizer at an average rate of 300 kg-N/ha/y.

The surface area of the plot in each site was 1.0 ha, its slope was less than 0.5% (and mostly less than 0.05%). For this reason, it was assumed surface runoff has been minimal and water movement in the unsaturated zone has been dominantly vertical. Meteorological stations recording rainfall, wind speed, solar radiation, temperature and humidity are located from 0.5 to 5 km far from the field sites.

Table 1. *Average meteorological parameters for the two field sites during the two monitored years.*

	Rainfall (mm/y)	Air Temp. (°C)	Solar Rad. (MJ/m ² /d)	Humidity (%)	Wind (Km/d)
CCR	813	13.2	1.60E ⁻⁰⁴	76	5.5
MON	699	13.6	1.66E ⁻⁰⁴	72	8.6

The predominant soil textures in Ferrara province are silty loam and silty clay (68% of the territory), while sandy soils are less common (11% of the territory). The CCR soils are in general moderately alkaline, with the upper horizons characterized by silty clay loam texture and moderate carbonates content; the lower horizons exhibit silty loam texture and are highly calcareous (Tab. 2).

Briefly, the hydrogeological units present in the CCR site are the unconfined aquifer composed of recent fluvial sandy deposits with clay and silt lenses, from 0 to around 4 m below ground level (b.g.l.), and the underlying aquiclude constituted of fluvial clay and silty sediments, from 4 to almost 14 m b.g.l..

Table 2. *Soil characterization for the two field sites*

	Pedological classification	Sedimentological environment	Textural classification
CCR	Haplic Calcisols	fluvial	silty loam
MON	Calcaric Arenosols	coastal plain	sand

The representative MON soil profile shows upper horizons of approximately 40-60 cm thickness characterized by fine sand texture, with moderate carbonates content and slightly alkaline pH; while the lower horizons exhibit alkaline pH and medium sand texture (Tab. 2). The hydrogeological units present in the MON site are the unconfined aquifer composed of coastal plain medium and fine sandy deposits, from 0 to around 12 m (b.g.l.), and the underlying aquiclude constituted of prodelta silt and clay sediments, from 12 to almost 15 m b.g.l. (Di Giuseppe et al., 2014).

Analytical and field methods

To better define the site stratigraphy triplicates core logs were drilled manually with an Ejielkamp Agrisearch auger equipment down to 2 m (b.g.l.). The soil stratification was divided in two distinct layers: the upper one stressed by tillage, roots growth and weathering and the lower undisturbed one (Tab. 3). In CCR site the upper layer was 0.75 m thick and in MON was 0.65 m, while the lower layer extended until 2 m b.g.l. at both sites. From collected core samples at 0.25, 0.50, 0.75, 1 and 2 m b.g.l., particle size curves were obtained using a settling tube for the sandy fraction and an X-ray Micromeritics Sedigraph 5100 for the finer one. Organic matter content was measured by loss of ignition method, while bulk density was determined gravimetrically.

Table 3. *Average grain size distribution, bulk density and organic matter content, measured for the upper and lower layers.*

Parameter	CCR	CCR	MON	MON
	Upper Layer	Lower Layer	Upper Layer	Lower Layer
Sand (%)	7.7	23.9	95.6	98.1
Silt (%)	63.2	58.1	3.0	1.9
Clay (%)	29.1	18.0	1.4	0.0
Bd (g/cm ³)	1.5	1.6	1.4	1.7
OM (%)	2.3	1.3	2.0	1.1

Two arrays of Watermark soil moisture probes were vertically inserted into augered holes, at the same depths of 0.25, 0.50, 0.75 and 1 m b.g.l. in each field site. Watermark soil moisture probes were used to monitor the soil water potential (measurement range 0-250 cbar). A copper-constantan thermocouple was inserted adjacent to each soil moisture probe to compensate for soil temperature. Standard Irrrometer tensiometers (measurement range 0-80 cbar) were installed at 0.25 and 0.50 m depths to monitor and correct any deviance of soil moisture probes readings.

A series of nested piezometer (2.5 cm inner diameter) screened from 1.5 to 4 m a.s.l., were installed near the soil moisture arrays to monitor the level and quality of groundwater. Monitoring started on 27 March 2008 and is still going on. LTC M10 Levellogger Solinst dataloggers were placed in piezometers to monitor hourly groundwater level, electrical conductivity and temperature. All the piezometers were sampled at variable intervals, via low flow purging, for major ions and TOC/TIC determination. Two arrays of soil solution suction samplers were installed at 0.25, 0.50, 0.75 and 1 m b.g.l. in each site to analyze soil water in the unsaturated zone. In addition to suction sampler, the unsaturated zone was sampled every four months by means of auger coring (from 0 to 2 m b.g.l.), and sediments were analyzed for major anions and cations.

Unsaturated zone sediment analysis consisted of a batch with a sediment/water ratio of 1:10, using 10 g of air dried sample dispersed in 100 ml of Milly-Q water (Millipore, US). A biological inhibitor (1 g/l phenylmercuric acetate) was added to prevent microbial activity and the solution was stirred for 1 hour and then allowed to stand for one day. The insoluble residue was removed by filtration and analyzed for major cations and anions.

In-well parameters were determined with the HANNA Multi 340i instrument which includes a HIcell-31 pH combined electrode with a built-in temperature sensor for pH measurements, a Cellox 325 galvanic oxygen sensor for DO measurements, a combined AgCl-Pt electrode for Eh measurement and a HIcell-21 electrode conductivity cell for EC measurements. The major cations, anions and oxianions (acetate and formate) were determined with isocratic dual pump ion chromatography ICS-1000 Dionex, equipped with an AS9-HC 4 x 250 mm high capacity column and an ASRS-ULTRA 4mm self-suppressor for anions, and a CS12A 4 x 250 mm high capacity column and a CSRS-ULTRA 4mm self-suppressor for cations.

Samples were filtered through 0.22 μm Dionex vial caps. An AS-40 Dionex auto-sampler was employed to run the analyses, Quality Control (QC) samples were run every 10 samples. The standard deviation for all QC samples run was better than 4%. Charge balance errors in all analyses were less than 5% and predominantly less than 3%. Total organic carbon (TOC) and total inorganic carbon (TIC) were determined with a carbon analyzer (Carbon Analyzer Shimadzu TOC-V-CSM) after acidification with one drop of 2 M HCl to remove dissolved carbonate.

Numerical modelling

The flow and transport processes were quantified by inverse modeling with the finite element numerical code HYDRUS-1D (Šimunek et al., 2009). The numerical grid was discretized in 200 nodes of 0.01 m each to form a regular grid 2 m long and a surface area of 1 m².

The grid was subdivided into two regions representing the upper and the lower soil horizons, initial water content conditions of collected soil cores (every 0.25 m) at each site, were measured via gravimetric methods and linearly interpolated along the vertical axis. At the soil surface, an atmospheric boundary condition with a maximum surface layer of 0.01 m was selected. As lower boundary condition variable pressure heads were specified in every model using groundwater levels.

The transport boundary condition at the surface was a prescribed concentration and at the lower boundary was a zero concentration gradient (free drainage) condition. Input concentrations of Br^- and NO_3^- were gained from soil extracts collected at the soil surface (0-5 cm) throughout the monitoring period. Volatilization of ammonia was quantified in batch experiments using an acid trap to recover the ammonia produced.

Results and discussion

Field monitoring

Since the most intense recharge occurs during spring time, Figure 3 shows a series of NO_3^- profile collected in CCR and in MON sites in April 2009 and 2010 before the fertilization. In CCR the NO_3^- concentration observed in April 2009 showed a peak at 3 m a.s.l. in

correspondence of the water table, while in the saturated zone NO_3^- decreased rapidly to concentrations below 50 mg/l.

Figure 1. NO_3^- depth profiles at CCR (on the left) and at MON (on the right) collected in April 2009 and April.

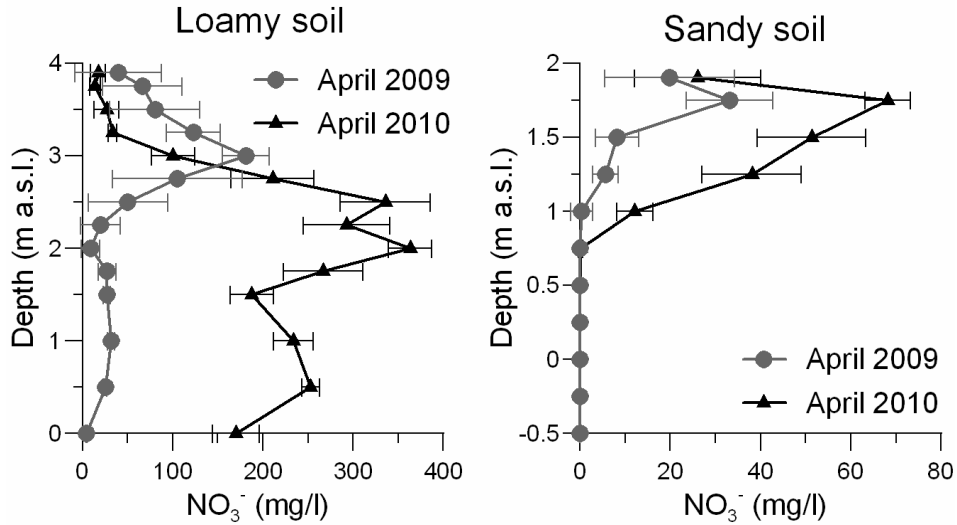

In April 2010 the observed NO_3^- profile showed very high concentration with a maximum peak below the water table. The elevated NO_3^- concentration was due to a combination of factors: (i) the water table was higher than in 2009, (ii) the temperature was lower than in 2009 and (iii) precipitation was less intense. The higher water table suggests that more NO_3^- trapped in the vadose zone can be dissolved in groundwater, the lower temperature may decrease denitrification rate and lower rainfall contributes to concentrate NO_3^- . The same trend is visible for the MON site, although NO_3^- concentrations were about five times lower and the profile appears quite different from CCR. In fact, NO_3^- was found only in the upper part of the profile, while below 1.0 m a.s.l. NO_3^- was always below detection limits. Nitrate disappearance below 1 m a.s.l. was attributed to denitrification supported by the addition of chicken manure, in April 2008, which provided labile organic matter used as an electron donor. The process is microbially catalyzed and can be written as an overall reaction:



The process involves also nitrite as intermediate compounds that are transiently produced and then reduced to nitrogen gas. When

denitrification is not limited by organic substrate, nitrite remains at low concentration. Otherwise, when organic substrates become limiting nitrite tends to accumulate. In fact, in MON site nitrite remained at very low level, always below 1 mg/l, while in CCR site concentrations up to 100 mg/l were occasionally recorded in suction cups. This provided an evidence of incomplete denitrification due to a lack of organic substrate. Ammonium was always observed below 2 mg/l and thus not shown.

In accordance, Figure 4 shows the TOC, acetate and TIC in both sites collected in April 2009 and April 2010. The TOC observed in CCR site was always lower than the TOC in MON site, this can be directly linked to chicken manure addition at MON site. Acetate concentration followed the same trend of TOC in both sites: in fact, TOC decreased with depth and also acetate, but the latter became exhausted at shallower depths since this organic acid is readily available as carbon source (Mastrocicco et al., 2011a). Acetate is one of the most reactive organic acids, produced as intermediate during organic matter degradation and thus is a good proxy to evaluate the reactivity of organic matter (Strobel, 2001). The elevated abundance of TOC after the addition of chicken manure in MON is another evidence of the excess of electron donors compared to nitrate, this led to a full nitrate reduction within the first meter of soil. On the contrary, at CCR site the TOC and acetate concentrations were not sufficient to support denitrification, leading to accumulation of nitrite. This conceptual model was also supported by the measured dissolved oxygen at MON and CCR sites in the piezometers: at MON oxygen was always below detection limits, while in CCR oxygen was present between 3 to 5 mg/l. Finally, the TIC vertical distribution supports the postulated denitrification reaction, because in MON the TIC concentration was elevated in the vadose zone, where the NO_3^- was consumed. While, in CCR the TIC increased towards the bottom of the aquifer, simply following the accumulation trend of total dissolved species (not shown).

Saturated zone monitoring

Figure 2 shows a variable groundwater table with large seasonal variations in the loamy soil, where the groundwater flow is linked with canals level. In particular, the sharp peak recorded the 21/06/2010 was due to a flood event that increased the level of the nearby canal of 2.5 m, but the soil moisture sensor placed at 1.0 m b.g.l. was not in saturation condition. This proves that the peak was due to groundwater fluctuation induced by the canal and not by recharge.

Figure 2. Groundwater level fluctuations of NO_3^- and EC trends in groundwater at CCR (loamy soil) throughout the monitoring period.

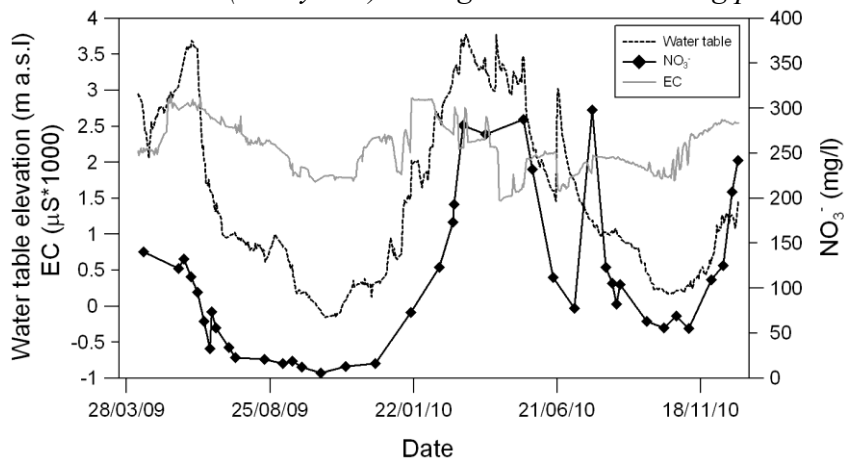

At the CCR site NO_3^- mass transfer to the unconfined aquifer was slow as shown in Figure 2 and concentrated at the end of the winter season, when the water table rose and brought in solution the available NO_3^- . For comparison with NO_3^- in Figure 2 is plotted also the EC, but is evident that there is not a direct relation between these two parameters. EC was generally increasing when the water table was rising, since the latter dissolved the salts accumulated in the vadose zone. While during the summer seasons EC decreased because groundwater was replaced by canal water that had a lower EC.

Figure 3. Groundwater level fluctuations of NO_3^- and EC trends in groundwater at MON site (sandy soil) throughout the monitoring period.

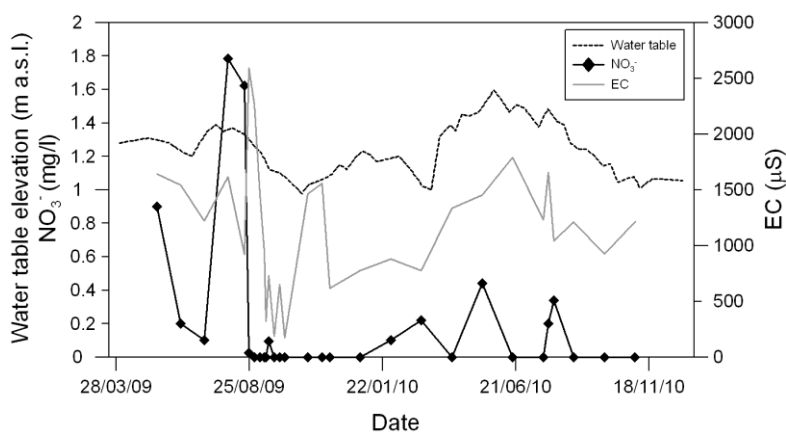

Figure 3 shows that in the MON site groundwater fluctuations were less pronounced than in CCR, since MON site is located near the coast and the water table fluctuations are smoothed. At the MON site, despite the fast

transfer of mass induced by the elevated permeability of the soil, NO_3^- concentration was very low. In fact, NO_3^- concentration never exceeded 2 mg/l confirming that the denitrification process efficiently removed all the NO_3^- . The EC monitoring was less continuous due to malfunction of the EC probe, thus only the EC measured during sampling campaigns is shown. In general, the EC seems to be related to the rainfall, exhibiting decreasing values after prolonged rainy periods although it is not possible to infer clear trends with these sparse data. Like for the CCR site, the EC trend can not be directly related to NO_3^- concentration in groundwater.

Numerical modelling

A good model fit of water content and head pressure at various depth was achieved in each site. A robust estimation of cumulative infiltration and evapotranspiration has been derived and the obtained water balance is considered reliable (R^2 : 92% for the loamy soil and 84% for the sandy soil). In the loamy soil, NO_3^- and Br^- percolated downwards very slowly, with sharp peaks located approximately 0.3 m below ground level after the harvest (Fig.4). In the sandy soil NO_3^- disappeared within the first meter of soil, while the Br^- peak was recovered approximately 1.5 m below ground level (Fig.1). The fast migration of Br^- in the sandy site was due to the elevated hydraulic conductivity of the soil (Tab. 4), while the disappearance of NO_3^- was essentially due to root uptake and denitrification (Fig.5). A good match between calculated and observed bromide concentrations was obtained in both sites via the inverse modelling procedure encoded in HYDRUS-1D. A robust reconstruction of the field velocity and of the dispersion coefficient was achieved matching observed and calculated Br^- concentrations.

Table 4. Hydraulic and transport parameters used in the numerical models for the two soil horizons of each site.

Parameter	Loam (0-0.75 m)	Loam (0.75-2 m)	Sand (0-0.55 m)	Sand (0.55-2 m)
K_s (m/d)	0.02	0.053	8.1	15.4
θ_s (m^3/m^3)	0.41	0.38	0.36	0.31
θ_r (m^3/m^3)	0.05	0.06	0.039	0.025
α (1/m)	0.12	0.51	8.50	11.21
n (-)	1.45	1.53	2.21	2.42
<i>Disper.</i> (m)	0.01	0.001	0.002	0.001
<i>Diff.</i> (m^2/d)	1e^{-4}	1e^{-4}	1e^{-4}	1e^{-4}
μNO_3^- (1/d)	0.003	0.004	0.01	0.1

Very small vertical dispersivity values were obtained (Tab. 4) in both sites, to account for the sharp concentration gradients observed in both fields. Mass recovery of bromide was near 90% for sandy and loamy soils, suggesting that homogeneous transport processes were present at the field scale. Results for the nitrogen mass balance are in good accordance with concentrations measured in the field for the same nitrogen species at the same sampling time.

Figure 4. Observed and calculated Br^- and NO_3^- concentrations along the soil profile in the loamy and sandy site after 120 day from the fertilization.

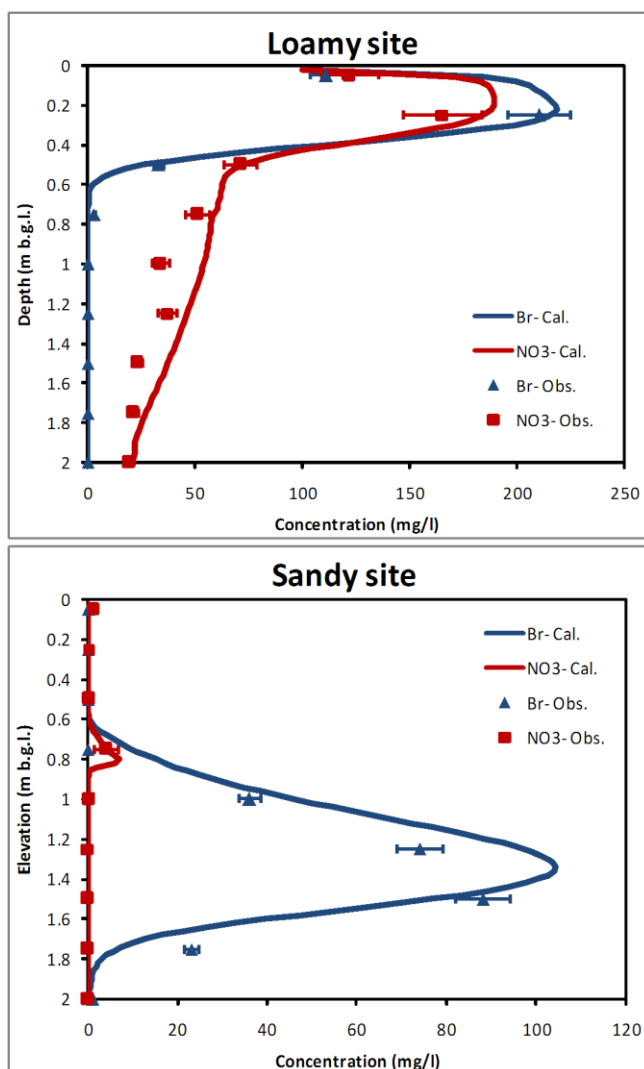
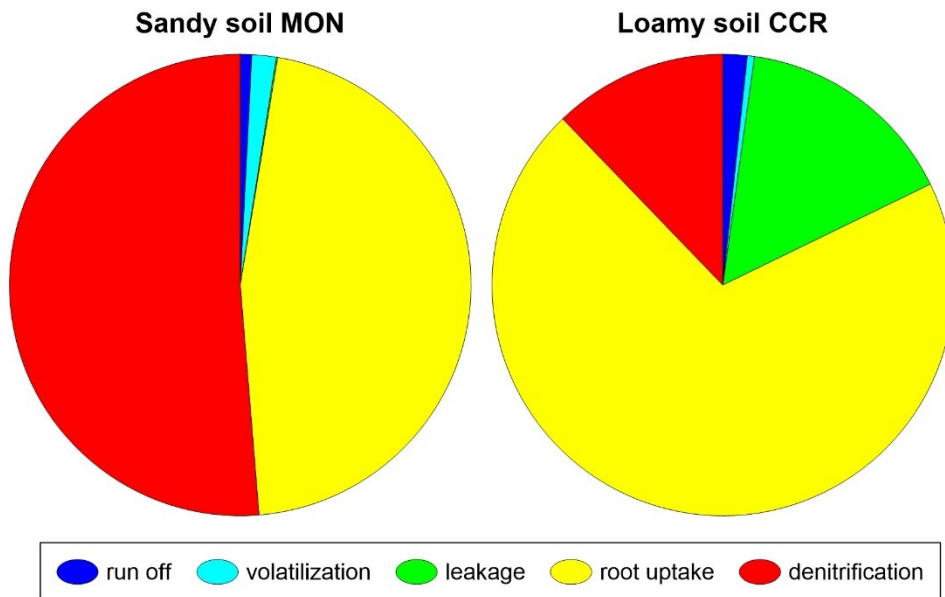

Figure 5. NO_3^- balance cake plot for: a) loamy soil; b) sandy soil.



NO_3^- leaching was observed in the loamy soil where the redox conditions remained oxidizing throughout the year, while in the sandy soil residual content of organic matter from fertilization with manure in the previous year (fraction of organic carbon: 0.042 and acetate: 34 mg/l) very likely decreased the redox potential to reducing conditions and favoured excess nitrate removal via denitrification preventing its migration towards the saturated zone (Fig. 5).

New experimental sites

The new sites for the new best management practices, were selected in silty loamy soils with different organic matter contents. Here a series of agricultural practices will be monitored for 4 years, starting from 2016. In each site, three parcels will be ploughed without compost to gain a standard deviation of the actual typical crops rotation, while three parcels will be ploughed with urban compost at 30 t/ha. Additionally, three parcels will be ploughed using minimum tillage techniques with compost at 30 t/ha. For the minimum tillage, a grubber disc with harrows will be used. Finally, three parcels will not be ploughed, but they will be amended with compost at 30 t/ha. The site have been already instrumented with the equipment described in the materials and methods sections, and each parcels in both sites will be modelled with HYDUS-1D

to the fate and transport of NO_3^- in different agricultural practices, including the field crop productivity as a term of comparison between different experimental parcels. The aim is to find the best compromise between productivity and environmental impact.

Conclusions

Results highlight the reliability of the use of field water monitoring, conservative tracers and numerical modelling jointly, to understand nitrate mass transfer rate and mass balance. For the practical interest of WFD application, this approach has evidenced that in the sandy soil, more permeable and intrinsically more vulnerable, the relatively low amount of organic matter lasting from manure use in the previous year, was sufficient to prevent nitrate leaking, by removing the excess via denitrification. This result highlights the need to pay attention to the kind of organic amendments used and to the relative degradation kinetics, which may also be heavily affected by farming type, organic or industrial. The results of the ongoing project will support to public bodies in territorial planning, land-use management in rural areas and promotion of low environmental-impact agriculture, supporting the implementation of EU regulations on integrated water management.

References

1. Aschonitis, V. G., Castaldelli, G., Colombani, N., Mastrocicco, M. (2016) *A combined methodology to assess the intrinsic vulnerability of aquifers to pollution from agrochemicals*. Arabian Journal of Geosciences, 9(7), 1-10.
2. Aschonitis, V. G., Salemi, E., Colombani, N., Mastrocicco, M. (2015) *Comparison of Different "S-index" Expressions to Evaluate the State of Physical Soil Properties*. Geotechnical and Geological Engineering, 33(4), 1055-1066.
3. Aschonitis, V. G., Salemi, E., Colombani, N., Castaldelli, G., Mastrocicco, M. (2013) *Formulation of indices to describe intrinsic nitrogen transformation rates for the implementation of best management practices in agricultural lands*. Water, Air, & Soil Pollution, 224(3), 1-14.

4. Aschonitis, V. G., Mastrocicco, M., Colombani, N., Salemi, E., Kazakis, N., Voudouris, K., Castaldelli, G. (2012) *Assessment of the intrinsic vulnerability of agricultural land to water and nitrogen losses via deterministic approach and regression analysis*. *Water, Air, & Soil Pollution*, 223(4), 1605-1614.
5. Barnes, R. T. and Raymond, P. A. (2010) *Land-use controls on sources and processing of nitrate in small watersheds: insights from dual isotopic analysis*. *Ecological Applications*, 20(7), 1961-1978.
6. Böhlke J.K., Wanty R., Tuttle M., Delin G., Landon M. (2002) *Denitrification in the recharge area and discharge area of a transient agricultural nitrate plume in a glacial outwash sand aquifer, Minnesota*. *Water Resources Research*, 38(7): 10.1–10.26.
7. Castaldelli, G., Colombani, N., Vincenzi, F., Mastrocicco, M. (2013) *Linking dissolved organic carbon, acetate and denitrification in agricultural soils*. *Environmental earth sciences*, 68(4), 939-945.
8. Cinnirella S., G. Buttafuoco, N. Pirronea (2005) *Stochastic analysis to assess the spatial distribution of groundwater NO₃⁻ concentrations in the Po catchment (Italy)*. *Environmental Pollution*, 133, 569–580.
9. Coyne, M.S. (2008) *Biological denitrification*. In: Schepers, J.S., Raun, W. (Eds.), *Nitrogen in Agricultural Systems*. ASA-CSSA-SSSA Agronomy Monograph 49, Madison, WI, pp. 197–249.
10. Di Giuseppe, D., Faccini, B., Mastrocicco, M., Colombani, N., Coltorti, M. (2014) *Reclamation influence and background geochemistry of neutral saline soils in the Po River Delta Plain (Northern Italy)*. *Environmental Earth Sciences*, 72(7), 2457-2473.
11. Galloway, J., N., Townsend, A., R., Erisman, J., W., Bekunda, M., Cai, Z., Freney, J., R., Martinelli, L., A., Seitzinger, S., P., Sutton, M., A. (2008) *Transformation of the nitrogen cycle: recent trends, questions, and potential solutions*. *Science*, 320, 889-892.

12. Kusel K. and Drake H.L. (1995) *Effect of environmental parameters on the formation and turnover of acetate by forest soils*. Applied Environmental Microbiology, 61: 3667–3675.
13. Liu X., Herbert S.J., Hashemi A.M., Zhang X., Ding G., (2006) *Effects of agricultural management on soil organic matter and carbon transformation – a review*. Plant Soil Environment, 52(12): 531–543.
14. Mastrocicco, M., Colombani, N., Palpacelli, S. (2009) *Fertilizers mobilization in alluvial aquifer: laboratory experiments*. Environ. Geol. 56(7), 1371–1381.
15. Mastrocicco M, Colombani N, Salemi E, Castaldelli G (2010) *Numerical assessment of effective evapotranspiration from maize plots to estimate groundwater recharge in lowlands*. Agricult. Wat. Manag. 97(9): 1389-1398.
16. Mastrocicco, M., Colombani, N., Castaldelli, G., Jovanovic, N. (2011a) *Monitoring and modeling nitrate persistence in a shallow aquifer*. Water Air & Soil Poll., 217 (1-4): 83-93.
17. Mastrocicco M, Colombani N, Palpacelli S, Castaldelli G. (2011b) *Large tank experiment on nitrate fate and transport: the role of permeability distribution*. Environ. Earth Sci. 63 (5): 903-914.
18. Mastrocicco M, Colombani N, Salemi E, Castaldelli G (2011c) *Reactive modeling of denitrification in soils with natural and depleted organic matter*. Water Air & Soil Poll. 222 (1-4): 205-215.
19. Mastrocicco M, Colombani N, Salemi E, Vincenzi F, Castaldelli G (2012) *The role of the unsaturated zone in determining nitrate leaching to groundwater* In “Groundwater Quality Sustainability” edited by A. Zuber, P. Maloszewski, S. Witczak and G. Malina, CRC Press ISBN: 9780415698412.
20. Onorati, G., Di Meo, T., Bussettini, M., Fabiani, C., Farrace, M., G., Fava, A., Ferronato, A., Mion, F., Marchetti, G., Martinelli, A. and Mazzoni, M. (2006) *Groundwater quality monitoring in Italy for the implementation of the EU water framework directive*. Physic and Chemistry of the Earth, 31, 1004–1014.

21. Rivett, M., O., Buss, S., R., Morgan, P., Smith, J., W., N., Bemment, C., D. (2008) *Nitrate attenuation in groundwater: A review of biogeochemical controlling processes*. Water Research, 42, 421-4232.
22. Šimunek J, Šejna M, Saito H, Sakai M, van Genuchten M Th, 2009. *The HYDRUS-1D Software Package for Simulating the Movement of Water, Heat, and Multiple Solutes in Variably Saturated Media*, Version 4.0, Dep. of Environ. Scie., Univ. of California Riverside, Riverside, California, USA, p. 315.
23. Spedding T., Hamel C., Mehuys G., Madramootoo C.A. (2004) *Soil microbial dynamics in maize growing soil under different tillage and residue management systems*. Soil Biology and Biochemistry, 36: 499–512.
24. Strobel B.W. (2001) *Influence of vegetation on low molecular weight carboxylic acids in soil solution—a review*. Geoderma, 99: 169–198.
25. Taylor P.G. and Townsend A.R. (2010) *Stoichiometric control of organic carbon–nitrate relationships from soils to the sea*. Nature, 464: 1178–1181.
26. Thompson, R.B. Martinez-Gaitan, C., Gallardo, M., Gimenez, C. Fernandez, M.D., (2007) *Identification of irrigation and N management practices that contribute to nitrate leaching loss from an intensive vegetable production system by use of a comprehensive survey*. Agric. Water Manage. 89, 261–274.
27. van de Perk M (2006) *Soil and water contamination: from molecular to catchment scale*, Taylor and Francis Group, London.
28. van Hees P.A.W., Vinogradoff S.I., Edwards A.C., Godbold D.L., Jones D.L. (2003) *Low molecular weight organic acid adsorption in forest soils: effects on soil solution concentrations and biodegradation rates*. Soil Biology and Biochemistry, 35: 1015–1026.

INFLUENCES OF INTERNATIONAL TRADE ON FOOD SECURITY

Raluca Andreea Ion¹, Dorel Dusmanescu²

Abstract

The paper investigates the role of international trade in ensuring food security in different regions of the world. Its objective is to identify the correlation between food security and agricultural trade, trying to answer the question whether food security is influenced by imports and exports with agricultural products and if so, to what extent. In answering this question, statistical data regarding the main food security indicator, namely dietary energy supply in different regions, and imports and exports of cereals are gathered and analyzed and indices of correlation between these indicators are calculated. The results show that strong correlations have been found for Africa, whose food security depends on cereal imports. Special references have been made to Romania and Serbia, when referring to cereals trade, which emphasizes the fact that both countries are net exporters and their cereal import dependency ratios are negative.

Key words: *food security, cereal import dependency, dietary energy supply*

Introduction

Trade in agricultural products is one of the oldest and most important activities in world history. It provides varied food consumption for people worldwide, but also plays an important role in the economy of all countries of the world. Trade is also important for its role in ensuring food security for countries which do not have natural resources of land and livestock, but they own other resources or develop other economic activities related to industry or services and they export the output of

¹ Associate Professor Raluca Andreea Ion, PhD., The Bucharest University of Economic Studies, Department of Agro-food and Environmental Economics, 6, Piata Romana, Bucharest, Romania, raluca-ion@eam.ase.ro

² Professor Dorel Dusmanescu, PhD., Petroleum and Gas University of Ploiesti, Department of Cybernetics, Economic Informatics, Finance and Accountancy, 39, Bd.Bucuresti, 100680, Ploiesti, Romania, doreld@upg-ploiesti.ro

these activities in order to import food and to ensure, as such, food security. The hypothesis tested in this piece of research can be expressed as “regions with scarce natural resources, such as Africa, Central America, part of Asia, generally developing market economies, are dependent on international trade for ensuring food security of their people”. Thus, statistical data about trade in agricultural products by region and food security are analyzed, trying to answer the question whether food security is influenced by imports and exports with agricultural products and if so, to what extent and for which regions.

As mentioned before, trade plays an important role in world economy. In order to ensure a fair and equitable trade for all countries, by the end of the Second World War, the United Nations used to have the initiative of setting up World Trade Organization. In 1947, it was firstly named The General Agreement on Tariffs and Trade (GATT), which entered into force on January 1, 1948. The main objective of the General Agreement on Tariffs and Trade was to create favourable conditions for conducting trade between countries. Member States undertake to respect the principles and rules on trade, such as to reduce, eliminate or consolidate tariffs and remove quantitative restrictions or other barriers to mutual trade liberalization.

Since the signing of the General Agreement on Tariffs and Trade (1947) and until 1967, six rounds of trade negotiations were held under GATT, which, overall, have led to important results on the theme of creating conditions for the development of international trade. During these rounds, a large number of tariff concessions were negotiated in the form of elimination, reduction or consolidation of import duties on a wide range of industrial products and certain agricultural products (Marinescu, 2011).

Uruguay Round (1986-1994) has special significance, because it establishes the World Trade Organization, instead of General Agreement on Tariffs and Trade. This round of negotiations is the most complex and largest among previous trade rounds, because trade in agricultural products is put under discussion for its liberalization. High protectionism in developed countries' agriculture is criticized because it drives to unfair international trade as long as agricultural products from developed countries reach international markets at lower prices, compared to agricultural output from developing countries, due to subsidies and interventionism instruments. This issue coupled with disparity in

resources distribution around the world between developed and developing countries drive to widening the gaps in ensuring food security in different regions. Countries from areas with scarce natural resources need to participate to international merchandise exchanges for buying food for their citizen. This paper investigates the countries' dependency on cereals imports and its contribution to food security.

Materials and methods

Food and Agricultural Organization of the United Nation uses several indicators for assessing food security in countries and regions. Among them, dietary energy supply is one of the most important. It shows the consumption expressed in calories per capita per day. In table 5, statistical data of dietary energy supply in developed and developing countries is illustrated and will be discussed later.

Another indicator of food security is cereal import dependency ratio. It shows how much of the available domestic food supply of cereals has been imported and how much comes from the country's own production. It results from formula:

$$CIDR = \frac{CI - CE}{CP + CI - CE} \cdot 100, \text{ where:}$$

CIDR= cereal import dependency ratio

CI= cereal imports

CE=cereal exports

CP= cereal production

It can be noticed that the denominator expresses the market supply and the numerator shows the reverse of trade balance. The indicator can be considered as the share of the remaining difference between cereal imports and exports in total supply of a market. Given this formula, the indicator assumes only values ≤ 100 . Negative values indicate that the country is a net exporter of cereals. In table 1, the cereal import dependency ratio is illustrated for different regions, countries and groups of countries.

Countries from Africa, Asia, Latin America and the Caribbean and Oceania, and generally the developing countries, have positive ratio of cereal import dependency, meaning they are net importers. The highest share registered in Oceania, followed by Africa. In developed countries

the cereal import dependency ratio is negative, showing that these countries are net exporters.

Table 1. *Cereal import dependency ratio (%)*

Regions/ Subregions/ Countries	1990- 92	1995- 97	2000- 02	2005- 07	2006- 08	2007- 09	2008- 10	2009- 11
Africa	25.2	23.0	29.5	28.7	28.8	29.2	28.8	29.4
Asia	6.2	7.0	5.1	5.0	5.1	5.3	6.0	6.0
Latin America and the Caribbean	10.7	11.3	11.9	9.3	7.8	6.4	5.7	4.7
Oceania	94.4	95.6	95.5	95.2	95.6	95.5	95.7	95.4
Developing countries	8.9	9.5	9.3	9.0	8.9	9.0	9.4	9.3
Developed countries	-12.8	-16.6	-15.7	-16.8	-16.1	-15.7	-17.1	-18.2
Romania	8.6	-4.8	0.5	-1.0	-4.0	-9.5	-20.7	-22.6
Serbia	-28.1	-1.7	-4.8	-20.9	-17.8	-20.4	-24.6	-31.8

Source: *FAO Food security indicators, 2016*

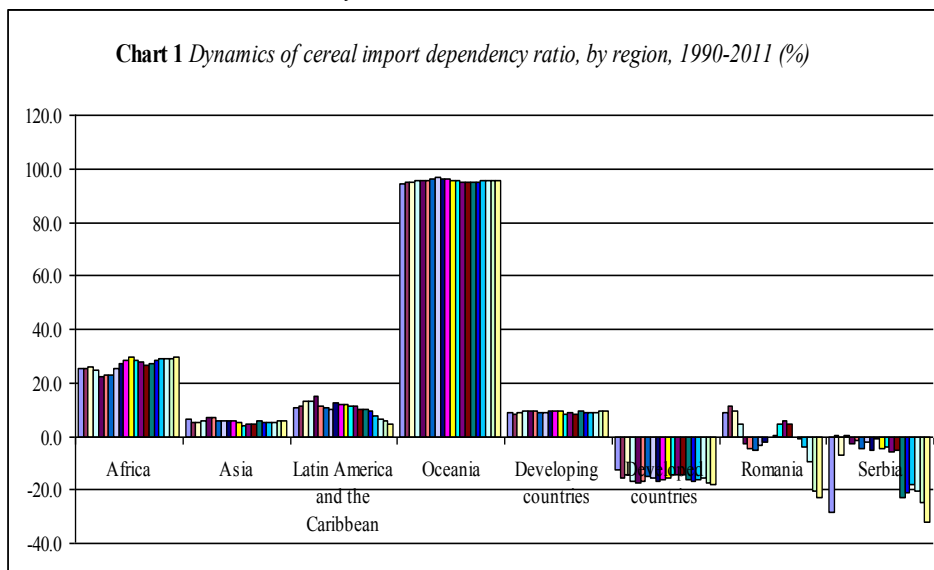

Source: *FAO Food security indicators, 2016*

As regards Romania and Serbia, both countries have negative ratio, except Romania in the period 1990-1992, at the start of the transition to market economy, when economical, social and political environment was unstable and countries consumed national strategic reserve of cereals.

In dynamics (Chart 1), oscillating trends of cereal import dependency ratio can be noticed in Africa, around the positive value of 25 per cent. In Asia, the level of dependency is much lower, between 5 and 7 per cent, but still positive, for the whole period.

In Latin America and the Caribbean, the cereal dependency ratio decreased from 10.7 per cent in the period 1990-1992, to 4.7 per cent in the period 2009-2011; but again, positive values, indicating that countries are net importers of cereals.

Developing countries have a cereal dependency ratio around the positive value of 9 per cent; developed countries increased their cereal imports independency from -12.8 per cent in the period 1990-1992 to -18.2 per cent in the period 2009-2011.

Romania performed an increasing independency of cereal import, in present it registered -22.6 per cent, a little lower than Serbia's value of ratio of -31.8 per cent. It can be noticed a growth in cereal import dependency in Serbia in the period 1995-2002, when political instability has driven to economical incertitude, as well.

Because the imports dependency ratio for cereals have been discussed above, we consider important to analyze the international trade with these products. In Table 2, imports, exports and trade balance of cereals are illustrated, by region and groups of countries, in the period 2011-2015.

It can be noticed that countries from Africa and Asia, and, generally, developing countries, have negative trade balance, for the whole period 2011-2015. Still, in Africa, the negative balance went to -24,385,409 USD, in 2014, and then it went to -16,700,679 USD, in 2015.

In Asia, the negative balance is around -30,000,000 UDS. In groups of developing countries, the negative balance was around -39,000,000 USD in 2011 and 2014, due to African countries high negative balance, and then it stabilized to -31,543,359 USD.

Developed countries have positive balance of cereals, which varies between 25,177,272 USD and 32,277,511 USD in the period 2011-2015. The highest values of positive balance in developed countries registered in 2011 and 2014, the years when the lowest negative balance registered in developing countries.

In Europe, trade balance reached a pick of 16,402,678 USD, in 2014, and then it stabilized around 14 million USD. The trade balance of cereals in America is higher than in Europe. It decreased from 30,179,895 USD, in 2011, to 21,854,595 USD, in 2015. Countries from Oceania have positive balance of cereals around 6 million USD. Both America and Oceania use cereals for sustaining livestock sector, which is developed in these regions of the world.

Table 2. *Imports, exports and trade balance of cereals, by region, 2011-2015, US Dollars*

Region	Item	2011	2012	2013	2014	2015
Africa	Imports	27,342,949	25,380,935	23,059,183	25,753,737	17,555,578
	Exports	1,730,289	1,602,829	1,854,193	1,368,328	854,899
	Trade balance	-25,612,660	-23,778,106	-21,204,990	-24,385,409	-16,700,679
America	Imports	19,955,027	21,159,494	22,211,351	20,174,300	17,405,696
	Exports	50,134,922	47,601,330	46,988,030	44,462,348	39,260,291
	Trade balance	30,179,895	26,441,836	24,776,679	24,288,048	21,854,595
Asia	Imports	48,869,067	53,493,036	55,445,002	55,262,808	48,803,728
	Exports	20,743,881	22,627,055	24,399,156	23,689,787	18,042,282
	Trade balance	-28,125,186	-30,865,981	-31,045,846	-31,573,021	-30,761,446
Europe	Imports	25,990,278	25,501,963	27,092,943	25,957,376	21,915,139
	Exports	35,469,243	39,711,936	41,647,994	42,360,054	36,761,348
	Trade balance	9,478,965	14,209,973	14,555,051	16,402,678	14,846,209
Oceania	Imports	818,484	827,274	706,042	790,663	660,445
	Exports	8,122,952	8,676,349	8,205,538	7,517,113	6,530,611
	Trade balance	7,304,468	7,849,075	7,499,496	6,726,450	5,870,166
Developing countries	Imports	85,062,345	89,095,814	88,843,460	91,691,174	75,388,558
	Exports	45,987,546	57,755,915	56,770,987	52,469,157	43,845,199
	Trade balance	-39,074,799	-31,339,899	-32,072,473	-39,222,017	-31,543,359
Developed countries	Imports	37,936,377	37,286,890	39,686,325	36,248,971	30,953,336
	Exports	70,213,888	62,464,162	66,324,291	66,928,479	57,604,232
	Trade balance	32,277,511	25,177,272	26,637,966	30,679,508	26,650,896

Source: *International Trade Statistic of International Trade Center*

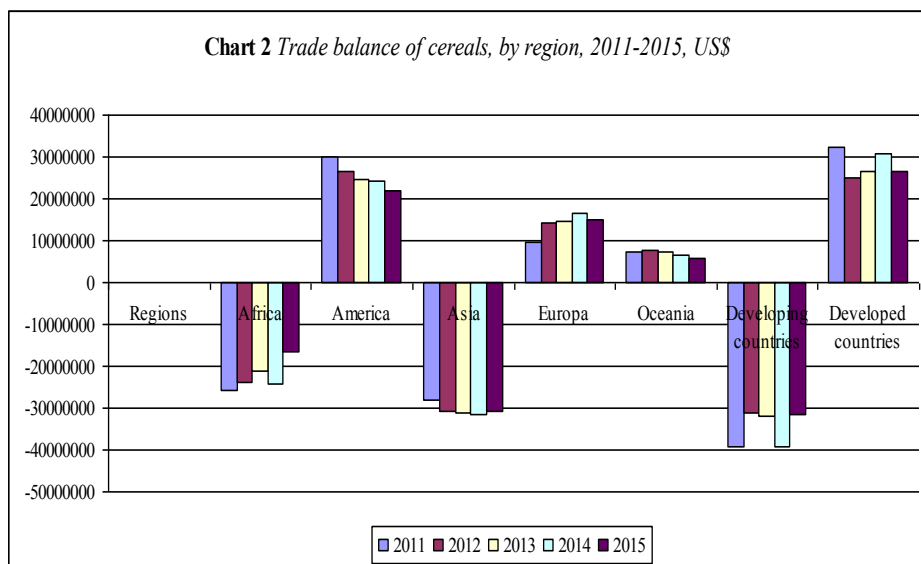

Source: *International Trade Statistic of International Trade Center*

Chart 2 clearly illustrates that developing countries, Africa and Asia have negative trade balance of cereals and developed countries, America, Europe and Oceania have positive trade balance of cereals.

Data in Table 3 show the imports, exports and trade balance for cereals in Romania and Serbia. Both countries have positive trade balance. In dynamics, imports increased from 449,728 USD to 596,809 USD in the period 2011-2015 in Romania, and significantly decreased from 30,209 USD to 5,772 USD in Serbia. The gap between exports and imports is much higher in Serbia than it is in Romania. Exports are 84 times higher than imports, in Serbia, and 3.7 times in Romania.

Table 3. *Imports, exports and trade balance of cereals, for Romania and Serbia, 2011-2015, US Dollars*

Region	Item	2011	2012	2013	2014	2015
Romania	Imports	449,728	480,154	434,868	391,249	596,809
	Exports	1,467,417	1,714,358	2,651,043	2,638,730	2,225,882
	Trade balance	1,017,689	1,234,204	2,216,175	2,247,481	1,629,073
Serbia	Imports	30,209	12,792	5,373	6,114	5,772
	Exports	557,065	667,911	486,789	605,084	485,120
	Trade balance	526,856	655,119	481,416	598,970	479,348

Source: *International Trade Statistic of International Trade Center*

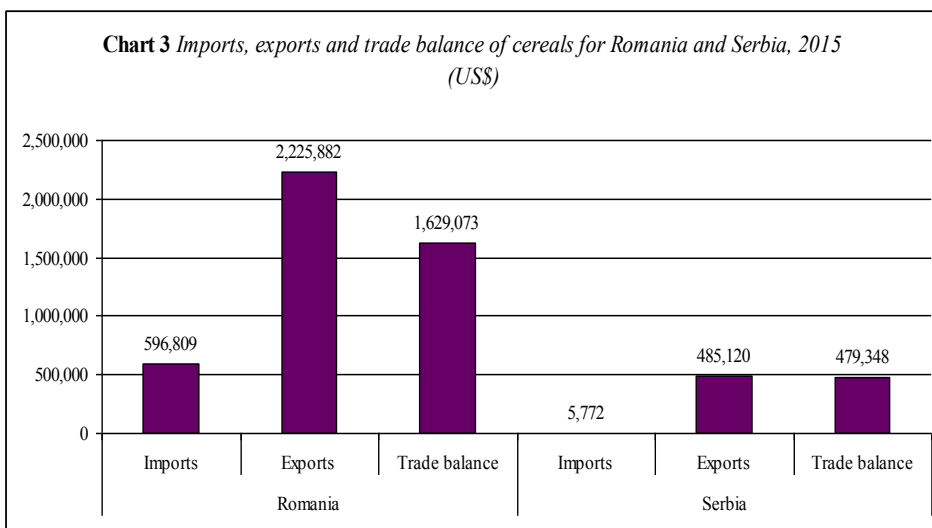

Source: *International Trade Statistic of International Trade Center*

As seen in Chart 3, the trade balance is positive, meaning that exports exceed imports with 1,629,073 USD, in Romania, and with 479,348 USD, in Serbia, in 2015.

Another indicator used by FAO to assess food security level in one country or region is the value of food imports over total merchandise exports. This indicator provides a measure of vulnerability and captures the adequacy of foreign exchange reserves to pay for food imports, which has implications for national food security depending on production and trade patterns.

The indicator show whether a country which has scare agricultural resources and which is forced, like this, to import food, has enough resources or products to export in order to get hold foreign currency for buying food from international markets.

The formula of this indicator is expressed as:

$$VFI = \frac{FI}{E_t} \cdot 100, \text{ where:}$$

VFI= value of food imports over total exports

FI= food imports

E_t= total exports

Expressed like this, the indicators show the share of food imports in total value of exports, pointing out whether the country have enough foreign exchange to buy food from international markets.

Table 4. *Value of food imports over total merchandise exports (%)*

Regions/ Subregions/ Countries	1990 -92	1995 -97	2000 -02	2005 -07	2006 -08	2007 -09	2008 -10	2009 -11	2010- 12	2011- 13
Africa	13	14	12	9	9	10	10	11	11	12
Asia	6	5	4	3	3	4	4	4	4	4
Latin America and the Caribbean	9	10	8	6	6	6	6	6	6	6
Oceania	20	17	18	16	16	17	18	18	17	19
Developing countries	7	7	5	4	4	5	5	5	5	5
Developed countries	7	6	5	5	5	5	6	6	5	6
Romania	16	6	6	7	8	9	9	8	7	7
Serbia	9	17	15	8	8	8	8	7	7	7

Source: *FAO Food security indicators, 2016*

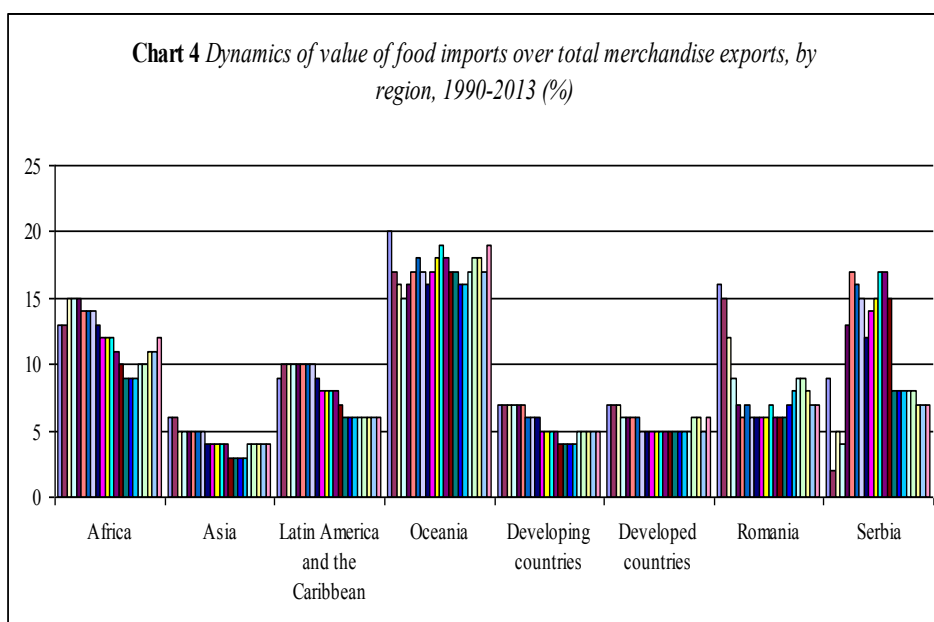

Source: *FAO Food security indicators, 2016*

Data in Table 4 show that the value of food imports over total merchandise exports is almost the same, on average, in developing countries compared to developed countries. Asia has the lowest values, between 3 and 6 per cent. In Africa, food imports account for 9 per cent to 14 per cent in total merchandise exports. The value of food imports over total merchandise exports is around 6 per cent in Latin America and the Caribbean.

In Romania and Serbia, the share of food imports in total merchandise exports used to have high values in the period 1990-2002, and then it stabilized to 7-9 per cent in the last ten years. Chart 4 show the values of food imports over total merchandise exports in dynamics, per regions, groups of countries, Serbia and Romania.

Dietary Energy Supply is an indicator of food security level of a country or region, showing the average consumption of food expressed in calories per person per day.

The Food and Agricultural Organization of the United Nation and World Health Organization recommend an average dietary energy supply of 3000 calories per person per day. In some countries, usually from developing market economies, the dietary energy supply are under this level, as seen in Table 5. This is the case of Africa, Asia, and Oceania and, generally, the developing countries. In developed countries, people consume over 3400 calories, more than what Food and Agricultural Organization of the United Nation and World Health Organization recommend.

The availabilities of food in calories and protein have a growing trend in the last 10 years in all regions of the world. However, the disparities between the developed countries in North America, Europe and Oceania and the developing and underdeveloped countries in South America, Africa and Asia are evident, both in terms of consumption of calories and protein (Ion, Popescu, 2013). In dynamics (Table 5 and Chart 5), in all regions, except Oceania, the dietary energy supply increased in the period 1990-2016. In Africa, the dietary energy supply is 2581 kcal/cap/day, in Asia 2813 kcal/cap/day, in Latin America and the Caribbean 3069 kcal/cap/day, in Oceania 2542 kcal/cap/day. Generally, the average consumption of calories is 2796 kcal/cap/day in developing countries and 3408 kcal/cap/day in developed countries.

Table 5. Dietary Energy Supply (kcal/caput/day)

Regions/Su bregions/C ountries	1990- 92	1995- 97	2000- 02	2005- 07	2010- 12	2011- 13	2012- 14	2013- 15	2014- 16
Africa	2320	2367	2412	2487	2555	2568	2571	2576	2581
Asia	2398	2525	2569	2625	2753	2768	2780	2796	2813
Latin America and the Caribbean	2669	2728	2802	2891	2976	2999	3017	3046	3069
Oceania	2454	2480	2438	2511	2544	2544	2543	2543	2542
Developing countries	2415	2522	2569	2630	2741	2756	2766	2781	2796
Developed countries	3257	3249	3345	3406	3377	3390	3401	3405	3408

Source: FAO Food security indicators, 2016

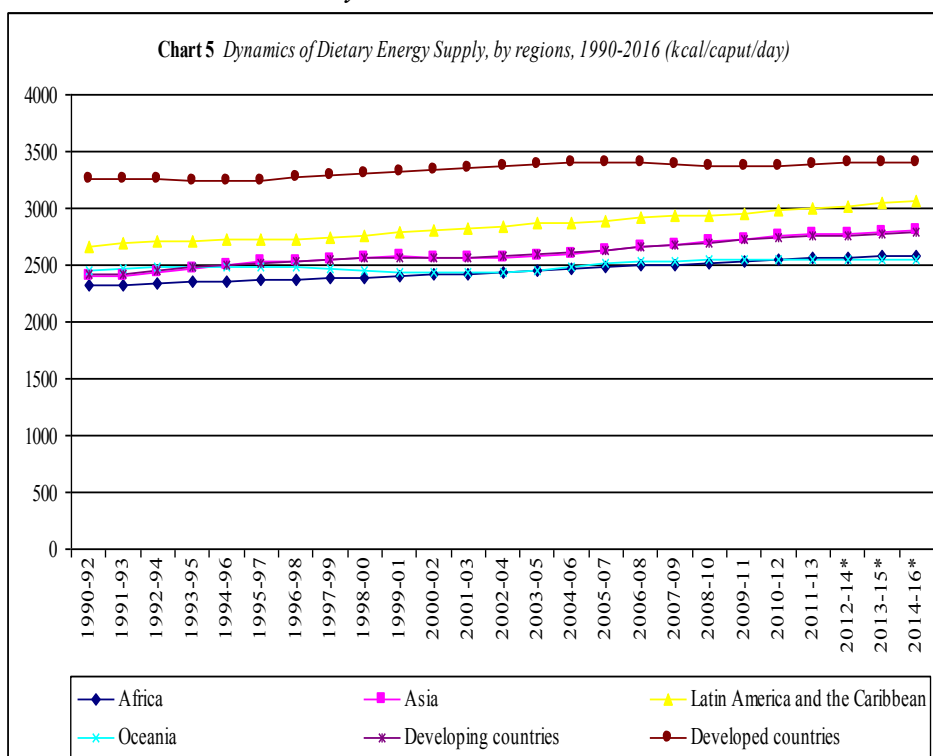

Source: FAO Food security indicators, 2016

As shown in other research (Ion, Popescu, 2013), gaps regarding the consumption of vegetal and animal calories remain the same, the share of calories of vegetal origin in total calories intake is lower in developed countries, compared to the regions of developing or underdeveloped countries: 73% in North America, 72% in Europe, 77% in South America, 70.5% in Oceania, 84% in Asia and 92% in Africa. Worldwide, the structure of daily food ration is 82% vegetal calories and 18% animal calories.

Results and discussions

This piece of research tries to answer the question whether food security is influenced by international trade with agricultural products, especially cereals, because the main part of diets is hold by these products. In developing countries from Africa, Asia and Central and South America, cereals hold over 50 per cent of total energy supply, expressed in calories. This lead to the hypothesis that there is a correlation between food security and cereals trade, in regions where agricultural resources are scare and countries must import food, especially cereals as main dish, in order to supply markets, satisfy consumption and ensure food security overall.

In Table 6, correlations between dietary energy supply and cereal import dependency are estimated, for regions in which food security is not ensured to levels recommended by Food and Agricultural Organization of the United Nation and World Health Organization (Africa, Asia, Oceania and, generally, developing countries).

Table 6. *Correlations between dietary energy supply and cereal import dependency*

Regions/ Groups of countries	Correlation index
Africa	0.7489
Asia	-0.1487
Latin America and the Caribbean	-0.7969
Oceania	0.004
Developing countries	0.2179
Developed countries	-0.1201

Source: *authors calculations based on statistical data*

The results show strong correlations in Africa, where the index is over 0.7, and weak correlations in Asia, Oceania, developing and developed countries, where the indices are -0.14, 0.004, 0.21 and -0.12.

In Africa, the daily diet is based on cereals, as seen in Table 7, the consumption of cereals, 151 kilograms per person per year, is the highest among other products. In addition, Africa is a region with scarce agricultural resources, which depends on cereals imports, as the high level of cereal import dependency ratio of 29.4 per cent shows (Table 1).

Table 7. Consumption of main agricultural products, by region, 2011 (kilograms per person per year)

Product	Africa	Asia	North America	South America	Europe	Oceania
Cereals	151	155	109	118	131	98
Fruits	62	64	113	103	92	103
Vegetables	65	161	122	52	122	99
Meat	18	31	117	73	76	105
Cow milk	44	54	250	130	219	178

Chart 6 Consumption of main agricultural products, by region, 2011 (kg/cap/year)

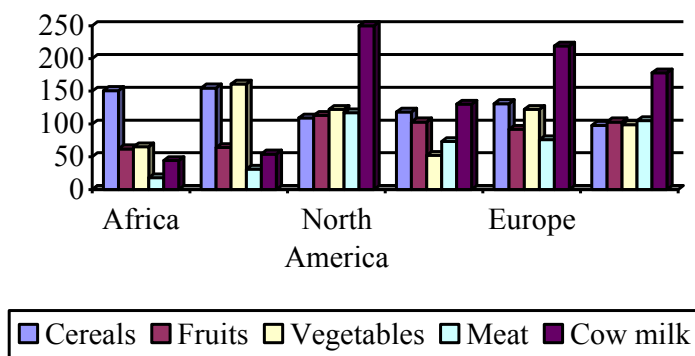

Source: FAOSTAT, 2016

Asia is a region with diverse natural endowments. What differentiates it from Africa is the fact that the daily diet is based on vegetables, as seen in Table 7, the consumption of vegetables, 161 kilograms per person, is the highest among other products. Asia is, also, the main producers of vegetables, so countries do not depend on international trade with vegetables for ensuring the daily dietary requirements.

In Table 8, correlations between dietary energy supply and value of food imports over total merchandise exports are estimated. The results show strong and negative correlations for Africa, Latin America and the Caribbean and, generally, developing countries, where coefficients are over 0.7, but in a negative correlation, meaning that the consumption of calories is inversely to the share of value of food imports in total merchandise exports.

The results can be interpreted in the way that, in countries from Africa and Latin America and the Caribbean, and, generally, from developing countries, when the share of food imports in total merchandise exports increases, the dietary energy supply decreases, and the other way around.

Table 8. *Correlations between dietary energy supply and value of food imports over total merchandise exports*

Regions/ Groups of countries	Correlation index
Africa	-0.7487
Asia	-0.6718
Latin America and the Caribbean	-0.9396
Oceania	-0.0748
Developing countries	-0.7287
Developed countries	-0.6418

Source: *authors calculations based on statistical data*

Conclusions

This piece of research investigated the role of international trade in ensuring food security, by analyzing the main indicators of the latter, correlated to imports and exports of cereals, in different regions and for groups of countries. Cereals have been chosen, because they are the daily diet for most people of the planet. In developed countries, the share of dietary energy supply derived from cereals, roots and tubers accounts for 32 per cent and in developing countries it reaches 56 per cent of total dietary energy supply.

The main findings are that international trade with cereals influences food security in regions where agricultural resources are scarce and daily diet is based, mainly, on cereals. It is the case of countries from Africa, where people consume mostly cereals, but where land, biological and technical resources for agriculture are scarce.

In other developing countries, correlations between international trade in cereals and food security are weak, mostly because these countries have a pattern of consumption based on vegetables, in the case of Asia, and on meat and milk, in the case of Oceania.

Implication of international trade on food security is larger than it was discussed in this approach. Further research should investigate the implication of liberalization of international trade in agricultural products on food security, due to the fact that, in current form, international trade is criticized as being unfair for countries which do not sustain their agricultural production with subsidies and whose products reach world markets at higher prices.

Literature

1. Banu, I. (2007). *Politici si strategii globale de securitate alimentara*, Editura Galati University Press, Galati.
2. Bran M., (2012), *Agro-Biodiversity Between Abundance Of Products And Environment Quality*, Quality – access to success, vol 13, S1: 52 – 57.
3. Cioban,C. (2007). *Politici si strategii de siguranta si securitate alimentara*, Editura Eurostampa, Bucuresti.
4. Diamond, J., (2005), *Collapse: How Societies Choose to Fail or Survive*, Allen Lane.
5. Dobre, I., (2013), *Research on the performance of farms' management in French agriculture*, Supplement of “Quality-Access to Success” Journal ISSN 1582-2559 Vol. 14, S1, pp.338 -343.
6. FAO. (2016). Food security indicators.
7. FAO, WFP, IFAD. (2015). *The State of Food Insecurity in the World*.
8. FAO. (2015). *Regional Overview of Food Insecurity Africa*.
9. FAO. (2015). *Regional Overview of Food Insecurity Latin America and the Carribean*.

10. Ion, R.A., Popescu, D.C. (2013). *Population Versus Food In The Context Of Food Security Worldwide*, International scientific meeting: Sustainable agriculture and rural development in terms of Republic of Serbia strategic goals implementation within Danube Region, Thematic Proceedings, pp.557-572.
11. International Trade Center. (2016). International Trade Statistic.
12. Marinescu, D.C. (2011). *Organizația Mondială a Comerțului ca forum de negociere și de reglementare în comerțul internațional*, PhD.thesis, University of Craiova, Craiova, Romania.
13. Roberts, P., (2009), *Sfârșitul hranei*, Ed. Litera Internațional, București, pg.18.
14. The Economist (2014). Food security in focus: Central & South America 2014.
15. Zahiu, L., (1992), *Agricultura mondială și mecanismele pieței*, Editura Arta Grafică, București.
16. Wijkman, A., Rockstrom, J., (2013), *Falimentarea naturii: negarea limitelor planetei*, Compania, București.

INTRINSIC VULNERABILITY OF AGRICULTURAL LANDS TO WATER AND NITROGEN LOSSES

Vassilis Aschonitis¹, Micòl Mastrocicco²

Abstract

The aim of the study is to propose an integrated approach for vulnerability assessment combining the LOS indices and other indices (AVI, SINTACS) of low data requirements, which can describe the vulnerability to pollution from conservative pollutants and nitrogen species for a) the topsoil, b) the unsaturated zone and c) the aquifer system. The separate analysis and combination of the 3 compartments can provide a more robust and detailed description of the response of hydrogeological systems to pollution. This attempt aims to change the current perspective of the vulnerability maps from two-dimensional (latitude, longitude) to four-dimensional visualization by adding the dimensions of depth and time. This study is an integration of the methods developed in the context of the EU.WATER project (<http://www.eu-water.eu>). The Sarigkiol Basin in Greece, is presented here as case study.

Keywords: *intrinsic vulnerability, agricultural land, water losses, nitrogen losses, groundwater.*

Introduction

The use of nitrogen (N) fertilizers in agricultural fields represents one of the most important non-point sources of pollutants. Excess of N from agricultural soils is a function of the physico-chemical soil properties, topography, water supply from irrigation and precipitation, climate and agronomic practices and constitutes a serious threat for aquifers and surface water habitats, with alluvial plains being the most impacted zones (Mastrocicco et al., 2009; 2011a; Castaldelli et al., 2013). Nitrate (NO₃⁻)

¹ Dr. Vassilis Aschonitis, Dept. of Life Sciences and Biotechnology, University of Ferrara. Tel. +390532455737 E-mail: schvls@unife.it

² Prof. Micòl Mastrocicco, Dept. of Environmental, Biological and Pharmaceutical Sciences and Technologies, Second University of Naples. Tel. +390823274609 E-mail: micol.mastrocicco@unina2.it

concentrations are spatially and temporally variable in aquifers due to variations in groundwater flow direction, NO_3^- attenuation rate (Mastrocicco et al., 2011a, 2011b) and also due to the high variability in agricultural practices in combination with soil type and climate, which highlight the site specificity effects on N load and N balance (Mastrocicco et al., 2010; Mastrocicco et al., 2011c). Efforts to reduce N loads from agricultural lands are ongoing through the definition of best management practices (Ashonitis et al., 2013). Regulations have not become fully effective yet, due to the high intrinsic complexity of the soil matrix and of site specificity, which enhance the difficulty to discriminate between the relative contribution of leaching and surface runoff, on the loss of nutrients from agricultural land (Mastrocicco et al., 2012). This limitation led scientists to develop various tools for groundwater vulnerability assessment. Groundwater vulnerability is classified into intrinsic vulnerability and specific vulnerability: the former is the ease with which a contaminant introduced into the ground can reach and diffuse into groundwater, taking into account the inherent geological, hydrological and hydrogeological characteristics but being independent of the nature of contaminants; the latter defines the vulnerability of groundwater to particular contaminants from specific activities (Gogu and Dassargues, 2000). Existing methods to assess groundwater vulnerability include:

1. process based mathematical models dealing with the water movement and the transport and transformations of dissolved compounds through the soil profile, such as GLEAMS (Knisel and Davis, 2000) and HYDRUS (Šimůnek et al., 2008);
2. process-based models combined with GIS, such as NLEAP (Shaffer et al., 1991), DAISY-MIKE SHE (Refsgaard et al., 1999) and GIS NIT-1 (De Paz et al., 2009), which are used to predict the spatial and temporal distribution of NO_3^- leaching and to assess NO_3^- contamination in groundwater at regional scale, but are limited by the large number of data required to describe the groundwater properties;
3. overlay indices methods based on ratings and weights, such as AVI (Van Stempvoort et al., 1992) and SINTACS (Civita and De Maio, 1997), that can be easily applied at regional scale via GIS because they require few and more accessible climatic, topographical, soil and geological data;
4. probabilistic-stochastic methods (Neshat and Pradhan, 2015a) that recently have introduced analysis on the uncertainty in vulnerability and risk mapping;

5. combined methods, such as LOS indices (Aschonitis et al., 2012, 2013, 2014; 2016), which have been calibrated via regression analysis based on the results of the deterministic model GLEAMS.

In view of the aforesaid literature, there is still a need of easy to use (not requiring model calibration) and flexible methodologies to assess the intrinsic vulnerability of groundwater resources. The aim of the study is to propose an integrated approach for vulnerability assessment combining the LOS indices and other indices of low data requirements, describing the vulnerability of a) the topsoil, b) the unsaturated zone and c) the aquifer system. The separate analysis and combination of the three compartments can provide a more robust and detailed description for the response of hydrogeological systems to pollution. This attempt aims to change the current perspective of the vulnerability maps from two-dimensional (latitude, longitude) to four-dimensional visualization by adding the dimensions of depth and time. This study is an integration of the methods developed within the EU.WATER project (<http://www.eu-water.eu>). The Sarigkiol basin in Greece, is presented here as case study.

Materials and methods

Study area

Sarigkiol Basin (Western Macedonia, GR) covers an area of 469 km² with a semi-arid Mediterranean climate. The mean annual temperature in the region is 11.3 °C. The monthly variation of precipitation has a bimodal pattern (with peaks in autumn and spring) with a total annual value of 640 mm. The min, max and mean altitude of the basin are 640, 1796 and 952 m a.s.l. (Fig.1a) and the min, max and mean slope are 0, 116.5 and 18%, respectively. The alluvial deposits in the centre of the basin host an unconfined aquifer superimposed on confined or semi-confined aquifers, covering an area of 60 km². The depth of the water table ranges from 7 to 75 m b.g.l.. Despite the documented heterogeneities, the aquifer can be considered uniform at the watershed scale. The most important activities in the basin are lignite mining, agriculture in the lowland region and livestock-farming on the fringes of the mountains. The basin is covered by agricultural land (32.7%), forests and semi natural areas (56.9%) and urban or artificial surfaces (10.4%) (Fig.1b). Agricultural fields exhibit 3 main domains: non-irrigated arable land (9318.7 ha), permanently irrigated land (5207.0 ha) and pastures (804.9 ha) (Fig.1c). Irrigation takes place mainly via private drillings and sometimes by pumping from

the Soulou stream and the draining channels. The crop distribution is: 61.45% hard wheat, 6.56% soft wheat, 6.28% barley, 9.89% sugar beet, 8.96% maize, 1.25% potatoes, 0.38% oat and 5.25% pastures. Maps on the topographic, climatic, soil, and environmental parameters were developed using ArcGIS 9.3 ESRI software. Data are available in the GIS platform of the EU.WATER project website (<http://www.eu-water.eu>).

Figure 1. a) Altitude, b) Main land uses and c) Sub-categories of agricultural areas of Sarigkiol basin

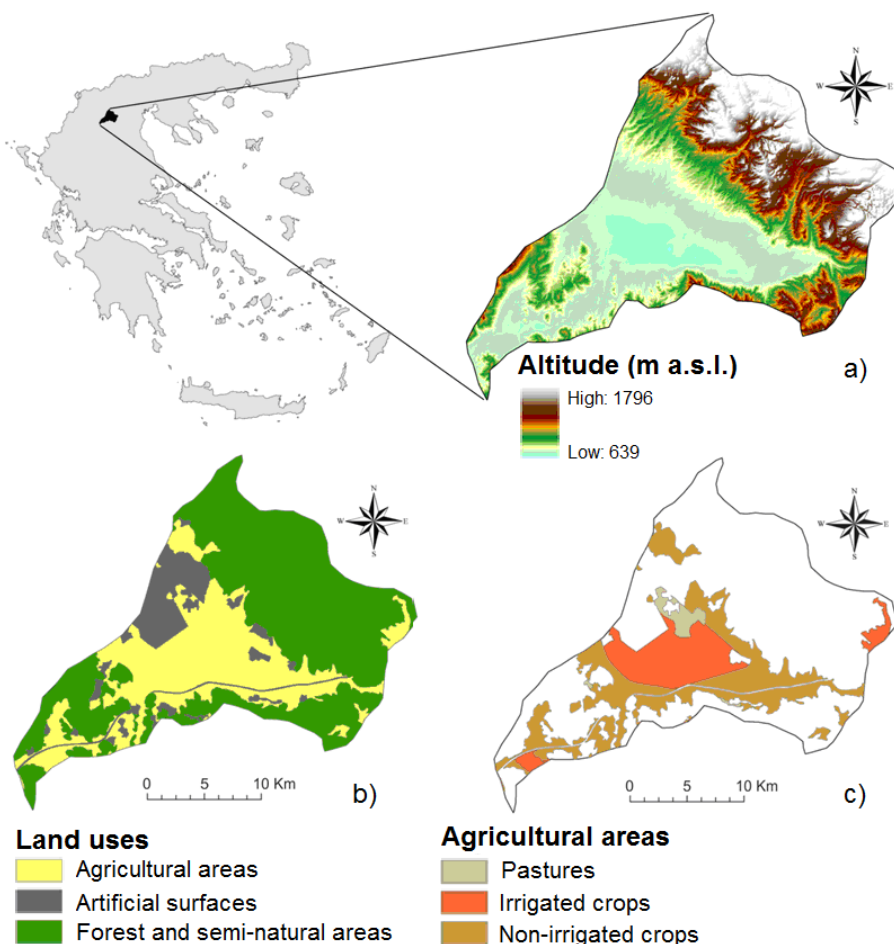

The general concept of LOS indices

LOS indices (Aschonitis et al., 2012; 2013; 2014; 2016) are divided in 2 sub-categories: LOSW and LOSN indices, which describe the theoretical

intrinsic annual rates of water and N cycle components, in agricultural soils covered by the reference crop used in Allen et al. (1998). The development–calibration of the indices was based on multiple regression analysis using as “observed values” the simulation results of the GLEAMS model (Knisel and Davis, 2000). Simulations were performed considering the top 30 cm of a square area of 1 ha with homogeneous soil profile, cropped with perennial grass (with extensive, uniform surface of dense actively growing coverage), using the assumption of Allen et al. (1998). The simulations concerned 384 scenarios covering all the possible combinations of the following parameters (Aschonitis et al., 2012):

1. Four cases of saturated hydraulic conductivity (21.6, 9, 1.8 and 0.18 cm h⁻¹), describing the mean characteristics of 4 hydrologic soil groups A, B, C and D according to the USDA SCS classification (USDA, 2007).
2. Three cases of organic matter (OM) (0.5, 2 and 5%) using the simplified chemical composition of OM adopted by Barry et al. (2002), leading to the minimum C/N ratios, to diminish the N immobilization effect and to maximize the mineralization potential calculated by the model. These assumptions were adopted to calculate the maximum rates of N release from manure application via GLEAMS model.
3. Four cases of soil surface slope (0, 1, 5 and 10%), linked to the curve number for grass surface using the equation of Getter et al. (2007).
4. Four cases of climatic conditions, representing the meteorological parameters of 4 stations in Sindos (Thessaloniki, Greece), Mirabello (Emilia-Romagna, Italy), Allardt (TN, USA) and Oakland (IA, USA).
5. Two cases for irrigation (irrigated and non-irrigated). Irrigation was adjusted automatically by the model to keep the soil moisture between 20 and 100 % of plant available water content in the soil profile. This range was introduced to give a realistic number of irrigation applications.
6. The fertilization rates for the reference crop were constant in all simulations and consisted in a total amount of 180 N kg ha⁻¹ and 90 P kg ha⁻¹ of a combined inorganic and organic fertilization. Fertilization was applied in 2 doses: (a) the first was 30 kg NO₃-N ha⁻¹, 30 kg NH₄-N ha⁻¹ and 40 kg P ha⁻¹ from inorganic fertilization and 60 kg N ha⁻¹ and 20 kg P ha⁻¹ from organic fertilization using 1.25 tn ha⁻¹ of dairy cattle manure (whose characteristics were obtained by Knisel and Davis, (2000)); (b) the second was 30 kg NO₃-N ha⁻¹, 30 kg NH₄-N ha⁻¹ and 30 kg P ha⁻¹ from inorganic fertilization.

The general form of LOS indices for water and N losses are:

$$\sqrt{LOS W - X_i} = a_1 \sqrt{K_{s_i}} + a_2 \sqrt{S_i} + a_3 \sqrt{PCP_i} + a_4 \sqrt{PE_i} + a_5 \sqrt{IR_i} \quad (1)$$

$$\sqrt{LOS\text{-}N - Y_i} = a_1\sqrt{OM_i} + a_2\sqrt{T_i} + a_3\sqrt{K_{s_i}} + a_4\sqrt{S_i} + a_5\sqrt{PCP_i} + a_6\sqrt{PE_i} + a_7\sqrt{IR_i} \quad (2)$$

where $LOS\text{-}X$ are the water losses (mm year^{-1}), $LOS\text{-}Y$ are the N losses ($\text{kg N ha}^{-1} \text{ year}^{-1}$), K_s is hydraulic conductivity (mm day^{-1}), S is surface slope (%), PCP is precipitation (mm year^{-1}), PE is potential or reference crop evapotranspiration (mm year^{-1}), IR is the irrigation required for covering the potential evapotranspiration deficit (mm year^{-1}), OM is organic matter (%), T is the mean annual temperature ($^{\circ}\text{C}$) and i is the location. In the case of water losses ($LOS\text{-}X$) (Eq.1), $-X$ denotes the general case, which becomes $-P$ for water losses from percolation and $-R$ for annual water losses from runoff. The $LOS\text{-}X$ indices can also be used to rank the losses of conservative pollutants. In the case of N losses ($LOS\text{-}N$) (Eq.2), $-Y$ denotes the general case, which becomes $-PN$, $-RN$, $-DEN$, $-MIN$, $-NIT$ for annual N losses from percolation, runoff, denitrification and annual rates of mineralization and nitrification. The coefficients of the models are given in Table 1. When the second term of Eqs.1 and 2 is ≤ 0 then $(LOS\text{-}X)^{1/2}$ and $(LOS\text{-}N)^{1/2}$ are set to 0. The models can be applied and mapped either directly using the square root or to square the results of $(LOS\text{-}X)^{1/2}$ and $(LOS\text{-}N)^{1/2}$ to derive values equivalent to (mm year^{-1}) and ($\text{kg N ha}^{-1} \text{ year}^{-1}$), respectively.

The description of ammonia (NH_3) volatilization is excluded from Eq.2 and its intrinsic annual rate ($\text{kg N ha}^{-1} \text{ year}^{-1}$) is calculated based on a modified version of the equation by Reddy et al. (1979):

$$LOS\text{-}VOLN_i = a_1 \left[1 - \exp(a_2 L) \right] \quad (3a)$$

$$L = 24 \left[\frac{60 + \{LOS\text{-}N - MIN\} - \{LOS\text{-}N - NIT\}}{60 + \{LOS\text{-}N - MIN\}} \right] \quad (3b)$$

where L is a term describing NH_3 availability for volatilization. When the term $L < 0$, then $L = 0$. The value of 24 in the term L describes the maximum potential amount of $\text{NH}_4\text{-N}$ in $\text{kg ha}^{-1} \text{ year}^{-1}$, which is available for NH_3 volatilization according to the amount and origin of NH_3 in the fertilizer application used in the GLEAMS scenarios ($60 \text{ kg ha}^{-1} \text{ year}^{-1}$ of $\text{NH}_4\text{-N}$ available from inorganic fertilization and $60 \text{ kg ha}^{-1} \text{ year}^{-1}$ of $\text{NH}_4\text{-N}$ from manure after mineralization). The maximum NH_3 volatilization potential was set to 5% for the inorganic fertilizers and to 35% for manure (Knisel et al., 1993), which correspond to 3 and 21 $\text{NH}_4\text{-N kg ha}^{-1} \text{ year}^{-1}$,

respectively. The ratio in the brackets of the term L describes the amount of $\text{NH}_4\text{-N}$ available for volatilization, considering the effects of nitrification and mineralization. The coefficients of Eq.3 are given in Table 1. The models of Eq.1 and 2 can be calculated with or without the term of irrigation IR (since GLEAMS scenarios also included non-irrigated simulations). The amount of annual irrigation for the reference crop can be calculated using the mean monthly values of PE_m and PCP_m :

$$IR = \sum_{m=1}^{12} IR_m \text{ where } IR_m = PE_m - PCP_m \text{ when } PE_m > PCP_m \text{ else } IR_m = 0 \quad (4)$$

where PE_m is the mean monthly potential evapotranspiration and PCP_m is the mean monthly precipitation of each month m . Another method for assessing the IR is the sum of positive differences between the monthly potential evapotranspiration and the real evapotranspiration estimated by simplified methods of water balance (Thornthwaite and Mather, 1957). The IR parameter is used to describe only irrigation cases from 0 to the maximum deficit of potential evapotranspiration, thus higher IR values to assess the effects of excessive irrigation are not recommended.

Table 1. Coefficients for calculating *LOSW* and *LOSN* models (Aschonitis et al., 2012; 2013)

Model \ Coefficient	a ₁	a ₂	a ₃	a ₄	a ₅	a ₆	a ₇
(<i>LOSW-P</i>) ^{1/2}	0.0941	-0.761	0.4185	-0.0487	0.0903	-	-
(<i>LOSW-R</i>) ^{1/2}	-0.0856	1.8573	0.9966	-0.5612	0.2384	-	-
(<i>LOSN-PN</i>) ^{1/2}	-0.1536	2.6981	0.0439	-0.2046	0.0471	-0.2515	-0.0116
(<i>LOSN-RN</i>) ^{1/2}	0.0121	-2.6559	-0.0228	0.3785	0.1298	0.2923	0.0047
(<i>LOSN-DEN</i>) ^{1/2}	0.32401	0.90274	-0.00569	-0.00784	-0.01198	-0.06962	-0.00067
(<i>LOSN-MIN</i>) ^{1/2}	0.03073	0.14438	-0.00151	0.00219	-0.00225	0.053	0.00071
(<i>LOSN-NIT</i>) ^{1/2}	0.01089	0.45989	-0.00044	-0.00268	-0.0042	0.02604	-0.00239
(<i>LOSN-VOLN</i>)	8.0978	-0.2049	-	-	-	-	-

Apart from the primary set of *LOSW* and *LOSN* indices, secondary combined indices can be derived as follow:

$$LOSW - PR = \{LOSW - P\} + \{LOSW - R\} \quad (5)$$

$$LOSN - PRN = \{LOSN - PN\} + \{LOSN - RN\} \quad (6)$$

$$LOSN - TN = \{LOSN - PN\} + \{LOSN - RN\} \\ + \{LOSN - DEN\} + \{LOSN - VOLN\} \quad (7)$$

where $LOSW-PR$ are the total water losses from both percolation and runoff (mm year^{-1}), $LOSN-PRN$ are the total N losses related to water losses from both percolation and runoff ($\text{kg N ha}^{-1} \text{ year}^{-1}$) and $LOSN-TN$ are the total N losses from all N outflow components (percolation, runoff, denitrification and NH_3 volatilization) ($\text{kg N ha}^{-1} \text{ year}^{-1}$). $LOSN-TN$ divided by the constant amount of applied N inorganic fertilizer ($120 \text{ kg N ha}^{-1} \text{ year}^{-1}$) used in the GLEAMS scenarios, plus the amount of N released from the mineralization described by $LOSN-MIN$, can be used to assess the fertilization failure index FFI of the reference field crop:

$$FFI\% = 100 \{ LOSN - TN \} / [120 + \{ LOSN - MIN \}] \quad (8)$$

The $FFI\%$ is of major significance because it relates inorganic N inflows originated directly by inorganic fertilizers and indirectly by mineralization versus the total N outflows, giving an integrated aspect about the intrinsic fertilization efficiency.

Additional indices were also performed combining both water and N losses to derive indicators on the quality of percolated and runoff waters:

$$CPW = 100 \frac{\{ LOSN - PN \}}{\{ LOSW - P \}} \quad (9)$$

$$CRW = 100 \frac{\{ LOSN - RN \}}{\{ LOSW - R \}} \quad (10)$$

where CPW is the relative N concentration of the percolated water under the root zone (mg N L^{-1}) and CRW is the relative N concentration of the runoff water (mg N L^{-1}). CPW and CRW are indicator values which do not consider mixing effects from other sources.

The organic/peat soils are an exception case in the LOS method since the GLEAMS simulations were performed for a range of OM up to 5%. Organic soils (with OM >10%) (Greve and Madsen, 1999) are excluded from the LOS analysis and set directly in the class of highest vulnerability for water and N losses due to the high permeability. Soils with OM in the range of 5-10% in transition zones close to soils with >10%, are also excluded and are accounted in the same vulnerability class with the organic soils. Soils with OM in the range of 5-10%, which are not close to natural organic soils can be included with caution in the LOS analysis.

Combination of LOS indices with other indices related to groundwater vulnerability

The LOS method provides a ranking of water and N fluxes in the top 30 cm of soil. A link of the LOS method with other indices and formulas related to the percolation and the saturated zones could provide a more integrated aspect about the vulnerability of groundwater to agrochemicals. Thus, methods such as SINTACS (Civita and De Maio, 2004) and AVI (Van Stempvoort et al., 1992) can be applied together with the LOS method. SINTACS was established for the analysis of hydrogeological and climatic impacts typical of the Mediterranean countries (Civita and De Maio, 2004). The acronym SINTACS stands for the 7 parameters included in the method: *Soggiacenza* (depth to water), *Infiltrazione efficace* (recharge), *Non saturo* (vadose zone), *Tipologia della copertura* (soil cover), *Acquifero* (aquifer), *Conducibilità idraulica* (hydraulic conductivity), *Superficie topografica* (slope of topographic surface). The rating assigned to each parameter must be multiplied by a weight to describe the environmental impact or the particular hydrogeological conditions. The SINTACS index is given by the following formula:

$$I_{SINTACS} = \sum_{J=1}^7 P_J W_J \quad (11)$$

where P_J is the rating of each parameter and W_J is the corresponding weight. The ratings and weights are given in Civita and De Maio (2004). Five type of weights are provided for “normal”, “severe”, “seepage”, “karst”, “fissure” and “nitrate” impact. The weights of “normal” impact were used in this study based on expert judgment.

AVI is a measure of groundwater vulnerability based on 2 physical parameters (Van Stempvoort et al., 1992): thickness of each sedimentary layer above the uppermost saturated aquifer surface (d_i) and estimated hydraulic conductivity (K_i) of each sedimentary layer. Based on d and K , the hydraulic resistance (AVI) is calculated. AVI is a theoretical factor describing the resistance of an aquitard to vertical flow and has the dimension of time, indicating the estimated travel time for water to move downward through the porous media above the uppermost saturated aquifer surface. Thus, the weighting of d and K for each sedimentary layer above the uppermost saturated aquifer surface, is not arbitrary but based on physical theory. The general AVI equation and the simplified version TT (relative transit time) for a unique layer are the following:

$$AVI = \sum_{l=1}^n \frac{d_l}{K_l} \rightarrow TT = \frac{Depth}{K_s} \quad (12a, b)$$

where n is the number of sedimentary units above the aquifer, AVI is the transit time of losses from the soil surface to reach the groundwater table (days), $depth$ is the distance of the groundwater table from the soil surface (m) and K_s is the hydraulic conductivity of the unsaturated zone ($m \text{ day}^{-1}$). LOS method was selected to assess the vulnerability to water (and conservative species) and N losses beneath the top 30 cm of the soil profile while AVI method was used to assess the vulnerability of the unsaturated zone. In both methods, the calculations are based on deterministic concepts and thus their results are not related to subjective expert judgement. For the aquifer vulnerability, SINTACS was analysed taking into account a) existing knowledge about the regional characteristics of the aquifer and b) the results of LOS and AVI which describe similar attributes of some parameters incorporated in SINTACS. At the end, LOS, AVI and SINTACS methods were combined to provide a more robust and detailed description of the response of the specific hydrogeological system to pollution, which creates a four-dimensional perspective of vulnerability, adding the depth and time (Fig. 2).

Figure 2. Conceptual model of integrated approach for vulnerability assessment (use of LOS for the 30 cm of the topsoil, use of AVI for the unsaturated zone and use of SINTACS for the aquifer, time is included in the units of LOS and AVI method)

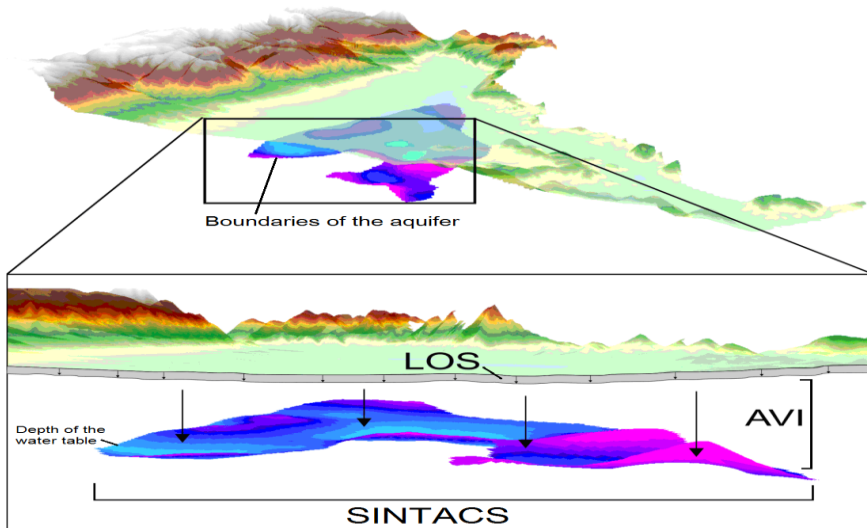

Results and discussion

The application of *LOSW* indices in Sarigkiol Basin showed that the water losses through percolation (*LOSW-P*) (Fig.3a) are lower in the center of the basin and increase towards the skirts, due to the transition from fine texture soils with low K_s to coarser soils with higher K_s , especially in the north-eastern region. The water losses through surface runoff (*LOSW-R*) are higher in the eastern region due to higher slopes while medium values are observed in the center of the region due to low K_s (Fig.3b). The total water losses (*LOSW-PR*) show that the most vulnerable zone to water losses is the north-eastern region of the basin (Fig.3c).

Figure 3. *LOSW* indices for water losses (mm year^{-1}) through a) percolation *LOSW-P*, b) runoff *LOSW-R* and c) percolation and runoff *LOSW-PR*.

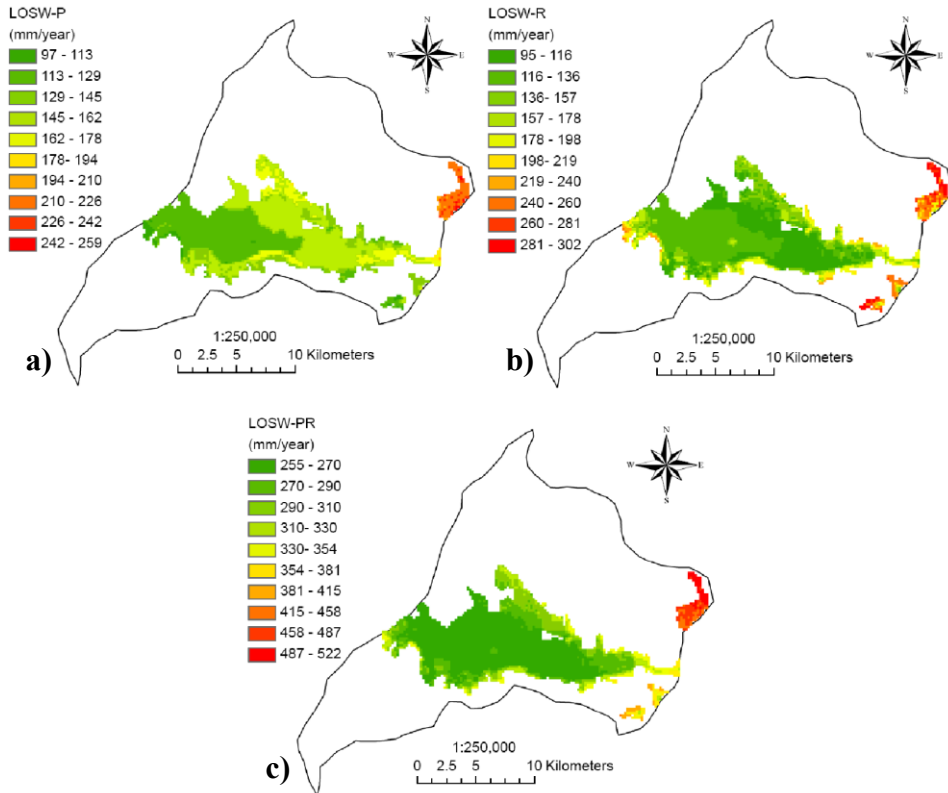

N losses through percolation (*LOS_N-P_N*) show a distribution analogous to *LOSW-P* (Fig.4a). N losses through surface runoff (*LOS_N-R_N*) (Fig.4b) show higher values in the eastern region due to higher slopes. The total N

losses (*LOSN-PRN*) (Fig.4c) show that the most vulnerable zone to N losses from percolation and runoff are the north-eastern region and the areas close to the aquifer boundaries. The intrinsic rates of denitrification (*LOSN-DEN*), mineralization (*LOSN-MIN*) and nitrification (*LOSN-NIT*) follow similar spatial patterns (Fig.5a, c, d) with higher values in lowland areas mainly due to the higher temperature. Another factor responsible for the higher values of *LOSN-MIN* in the lowlands is the higher *OM*. The *LOSN-DEN* is higher in these territories not only due to temperature but also due to the lower K_s and the higher availability of NO_3^- , due to the higher rates of nitrification. NH_3 volatilization (*LOSN-VOLN*) follows an opposite patterns (Fig.5b), with higher values at the upland colder north-eastern region, due to the low nitrification rates.

Figure 4. *LOSN* indices for N losses ($\text{kg N ha}^{-1} \text{ year}^{-1}$) through a) percolation *LOSN-PN*, b) runoff *LOSN-RN* and c) percolation and runoff *LOSN-PRN*

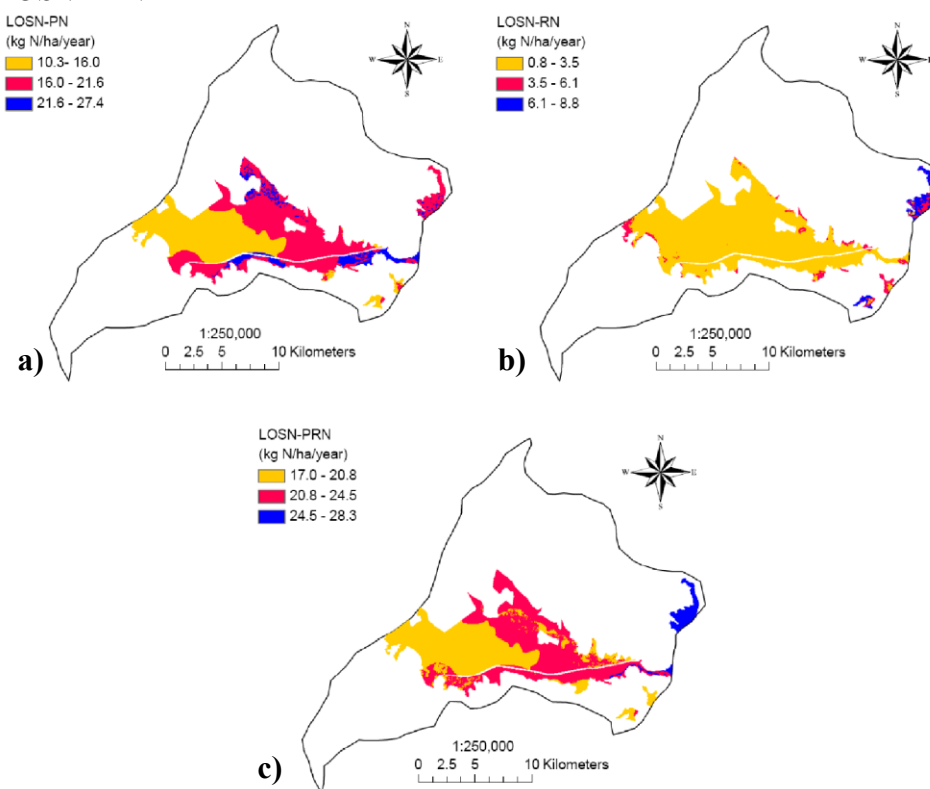

Very interesting is the comparison between the total N losses *LOSN-TN* (Fig.5e) and the *FFI%* (Fig.5f) which do not follow similar patterns.

LOSN-TN is higher in the lowlands and its values are gradually decreased from the lowland central-west part to the eastern upland region while *FFI%* is higher in the west upland regions, shows intermediate values in the central-west lowlands and low values in the transitional zones between lowlands and uplands. The difference between *LOSN-TN* and *FFI%* occurs because the mineralization rates in the west uplands is significantly lower (higher failure to mineralize organic fertilizers and natural OM) in comparison to the lowlands (difference of $\sim 30 \text{ kg N ha}^{-1} \text{ year}^{-1}$ in *LOSN-MIN*) (Fig.5c) while their difference in terms of total N losses *LOSN-TN* is $\sim 10 \text{ kg N ha}^{-1} \text{ year}^{-1}$ (Fig.5e). Thus, for the upland regions, the denominator of *FFI* equation (Eq.8) is reduced by $30 \text{ kg N ha}^{-1} \text{ year}^{-1}$ while the nominator is reduced by $\sim 10 \text{ kg N ha}^{-1} \text{ year}^{-1}$ leading to higher values of *FFI%* in comparison to the lowlands.

Figure 5. Intrinsic rates of a) denitrification *LOSN-DEN*, b) NH_3 volatilization *LOSN-VOLN*, c) mineralization *LOSN-MIN*, d) nitrification *LOSN-NIT*, e) total N losses *LONS-TN* and e) fertilization failure index *FFI%*

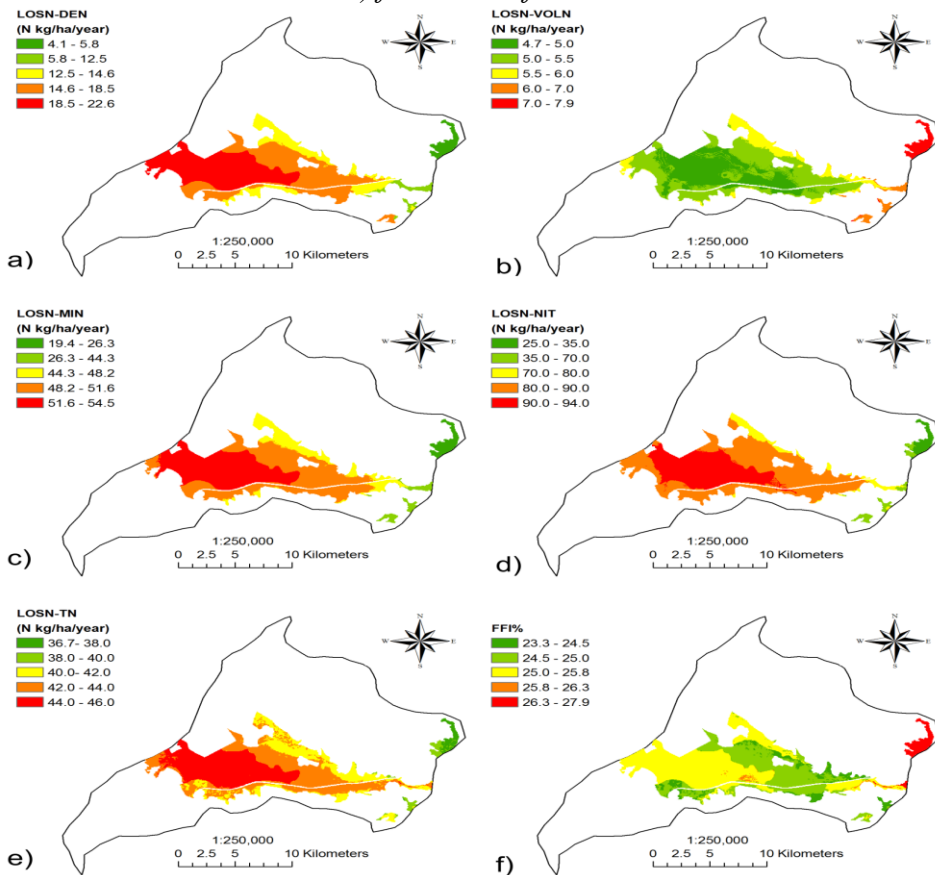

The higher relative N concentrations in the percolated water (*CPW*) (Fig.6a) are observed in the regions close to the edge of the aquifer, while the higher relative N concentrations in the runoff water (*CRW*) (Fig.6b) are observed in the north-eastern region of the basin. The relative transit time *TT* (*AVI*) map (Fig.6c) is restricted only in the region defined by the boundaries of the aquifer (Fig.2) and its values are gradually increased from the lowland central-west part to the eastern upland region. The *SINTACS* map (Fig.6d) shows that the northern and western zones of the aquifer are in the high vulnerable class because of the presence of old talus stones giving high values of infiltration rate. In the southern part, a high vulnerable stripe is present in correspondence with fractured limestone and dolomite outcrops. The central part of the aquifer (50% of the total surface examined) is classified as low vulnerable because of the presence of fine lacustrine and alluvial deposits with low K_s .

Figure 6. a) Relative N concentration for the percolated water *CPW*, b) Relative N concentration for the surface runoff water *CRW*, c) Relative transit time *TT* of the percolated water to reach the groundwater table (days) and d) groundwater vulnerability according to *SINTACS*

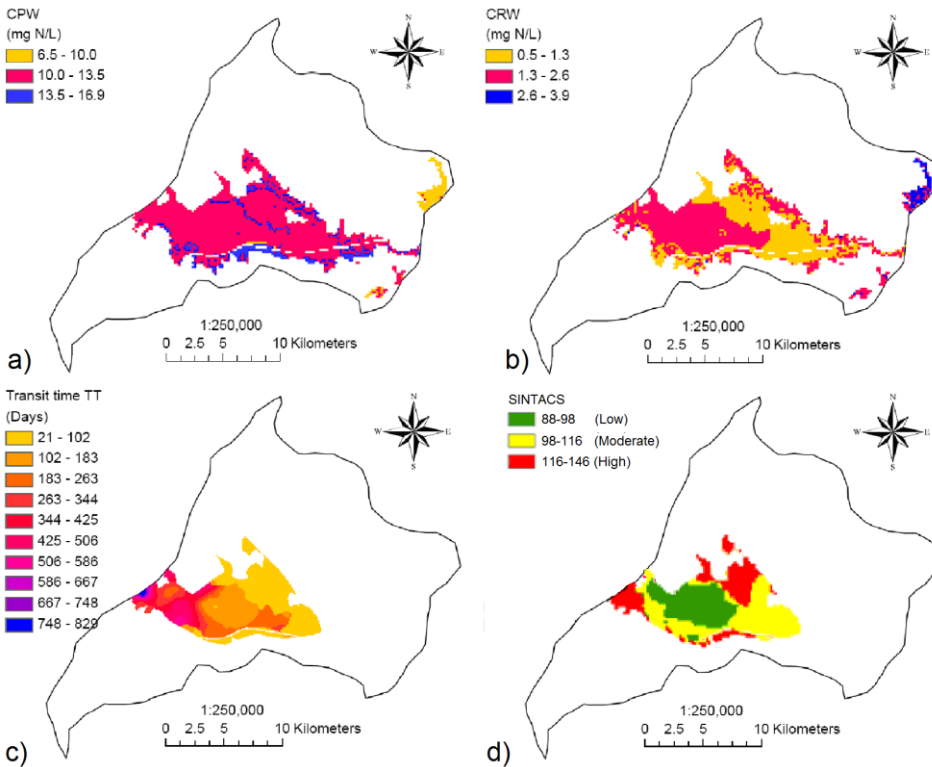

Conclusions

The application of different indices to assess the intrinsic vulnerability of the Sarigliol basin (Greece) showed that their combination could provide an overall view linked to the fate and transport of pollutants from the topsoil to the aquifer. The LOS method provided information about the intrinsic vulnerability of the topsoil (30 cm) to water and N losses, the AVI method described the vulnerability of the unsaturated zone to allow pollutants to reach the aquifer while the aquifer vulnerability was analyzed using SINTACS. The conceptual approach of combining all indices lead to a four-dimensional description of vulnerability by adding the dimensions of depth and time. The dimension of depth was described by the 3 layers of LOS-AVI-SINTACS, while the dimension of time was introduced by LOS and AVI methods which provide quantitative results in time. The use of LOS method also highlighted the limitation of the other methods in describing the potential contribution to pollution of areas (especially upland areas) which are out of the aquifer boundaries. The indices can be easily employed in large-scale applications with few data using GIS and they can efficiently help Decision Support Systems and cost-benefit analyses to improve the environmental and economic sustainability of agricultural systems. The combination of the aforementioned methods can be used as a robust tool to establish detailed monitoring programmes and measures to achieve the Water Framework Directive objectives of good groundwater status.

References

1. Allen, R. G., Pereira, L. S., Raes, D., Smith, M. (1998) *Crop evapotranspiration – Guidelines for computing crop water requirements*. Food and Agriculture Organization of the United Nations, FAO, Rome, Italy.
2. Aschonitis, V. G., Mastrocicco, M., Colombani, N., Salemi, E., Kazakis, N., Voudouris, K., Castaldelli, G. (2012) *Assessment of the intrinsic vulnerability of agricultural land to water and nitrogen losses via deterministic approach and regression analysis*. *Water, Air, & Soil Pollution*, 223(4), 1605-1614.
3. Aschonitis, V. G., Salemi, E., Colombani, N., Castaldelli, G., Mastrocicco, M. (2013) *Formulation of indices to describe intrinsic nitrogen transformation rates for the implementation of best management practices in agricultural lands*. *Water, Air, & Soil Pollution*, 224(3), 1-14.

4. Aschonitis, V. G., Mastrocicco, M., Colombani, N., Salemi, E., Castaldelli, G. (2014) *Assessment of the intrinsic vulnerability of agricultural land to water and nitrogen losses: Case studies in Italy and Greece*. IAHS-AISH Proceedings and Reports, 364, 14-19.
5. Aschonitis, V. G., Castaldelli, G., Colombani, N., Mastrocicco, M. (2016) *A combined methodology to assess the intrinsic vulnerability of aquifers to pollution from agrochemicals*. Arabian Journal of Geosciences, 9(7), 1-10.
6. Barry D. A., Prommer H., Miller C. T., Engesgaard P., Brun A., Zheng C. (2002) *Modelling the fate of oxidisable organic contaminants in groundwater*. Advances in Water Resources, 25, 945-983.
7. Castaldelli, G., Colombani, N., Vincenzi, F., Mastrocicco, M. (2013) *Linking dissolved organic carbon, acetate and denitrification in agricultural soils*. Environmental earth sciences, 68(4), 939-945.
8. De Paz, J. M., Delgado, J. A., Ramos, C., Shaffer, M. J., Barbarick, K. K. (2009) *Use of a new GIS nitrogen index assessment tool for evaluation of nitrate leaching across a Mediterranean region*. Journal of Hydrology, 365, 183-194.
9. Civita, M., De Maio, M. (2004) *Assessing and mapping groundwater vulnerability to contamination: the Italian "combined" approach*. Geofisica Internacional, 43(4), 513-532.
10. Getter, K. L., Rowe, D. B., Andresen, J. A. (2007) *Quantifying the effect of slope on extensive green roof stormwater retention*. Ecological Engineering, 31(4), 225-231.
11. Gogu, R., Dassargues, A. (2000) *Current trends and future challenges in groundwater vulnerability assessment using overlay and index methods*. Environmental Geology, 39(6), 549-559.
12. Greve M. H., Madsen, H. B. (1999). *Soil Mapping in Denmark*, European Soil Bureau-Report No.6.
13. Knisel, W. G., Leonard, R. A., Davis, F. M. (1993) *GLEAMS: groundwater loading effects of agricultural management system*. Athens: University of

Georgia, Coastal Plain Experiment Station. Bio. Agric. Eng. UGA CPES-BAED Publication No.5.

14. Knisel W. G., Davis F. M. (2000) *GLEAMS, Groundwater Loading Effects from Agricultural Management Systems V3.0*. Publ. No. SEWRL-WGK/FMD-050199, U.S.D.A., Tifton, Georgia.
15. Mastrocicco, M., Colombani, N., Palpacelli, S. (2009) *Fertilizers mobilization in alluvial aquifer: laboratory experiments*. Environmental Geology, 56(7), 1371–1381.
16. Mastrocicco, M., Colombani, N., Castaldelli, G., Jovanovic, N. (2011a) *Monitoring and modeling nitrate persistence in a shallow aquifer*. Water Air & Soil Pollution, 217(1-4): 83-93.
17. Mastrocicco, M., Colombani, N., Palpacelli, S., Castaldelli, G. (2011b) *Large tank experiment on nitrate fate and transport: the role of permeability distribution*. Environmental Earth Sciences, 63(5): 903-914.
18. Mastrocicco, M., Colombani, N., Salemi, E., Castaldelli, G. (2011c) *Reactive modeling of denitrification in soils with natural and depleted organic matter*. Water Air & Soil Pollution, 222(1-4): 205-215.
19. Mastrocicco, M., Colombani, N., Salemi, E., Vincenzi, F., Castaldelli, G. (2012) *The role of the unsaturated zone in determining nitrate leaching to groundwater* In “Groundwater Quality Sustainability” edited by A. Zuber, P. Maloszewski, S. Witczak and G. Malina, CRC Press ISBN: 9780415698412.
20. Mastrocicco, M., Colombani, N., Salemi, E., Castaldelli, G. (2010) *Numerical assessment of effective evapotranspiration from maize plots to estimate groundwater recharge in lowlands*. Agricultural Water Management, 97(9), 1389-1398.
21. Neshat, A., Pradhan, B. (2015) *An integrated DRASTIC model using probabilistic based frequency ratio and two new hybrid methods for groundwater vulnerability assessment*. Natural Hazards, 76(1), 543-563.

22. Reddy, K. R., Khaleel, R., Overcash, M. R., Westerman, P. W. (1979) *A nonpoint source model for land areas receiving animal wastes: II. Ammonia volatilization*. Transactions of ASAE, 22(6), 1398-1405.
23. Refsgaard, J. C., Thorsen, M., Jensen, J. B., Kleeschulte, S., Hansen, S. (1999) *Large scale modeling of groundwater contamination from nitrate leaching*. Journal of Hydrology, 221, 117-140.
24. Shaffer, M. J., Halvorson, A. D., Pierce, F. J. (1991) *Nitrate leaching and economic analysis package (NLEAP): Model description and application*. In Managing Nitrogen for Groundwater Quality and Farm Profitability, 285-322. Soil Science Society of America, Madison (WI).
25. Šimůnek, J., van Genuchten, M. Th., Šejna, M. (2008) *The HYDRUS-1D software package for simulating the one-dimensional movement of water, heat, and multiple solutes in variably-saturated media*. Version 4.0. HYDRUS Software Ser. 3. Dep. of Environmental Sciences, Univ. of California, Riverside.
26. Thornthwaite, C. W., Mather, J. R. (1957) *Instructions and tables for computing potential evapotranspiration and the water balance*. Climatology, 10(3), Centerton, N.J. Drexel Inst.
27. USDA (2007) *National Engineering Handbook. Hydrologic Soil Groups. Chapter 7*. (210–VI–NEH).
28. Van Stempvoort, D., Ewert, L., Wassenaar, L. (1992) *AVI: a method for groundwater protection mapping in the prairie provinces of Canada*. Prairie Provinces Water Board Report 1-14, Regina, SK.

POSSIBILITIES OF USING RENEWABLE ENERGY SOURCES IN AGRICULTURE OF THE REPUBLIC OF SERBIA

Željko Despotović¹, Miloš Jovanović¹, Ilija Stevanović¹

Abstract

In the paper it is presented the review and the possibilities of using renewable energy sources (RES) in Serbian agriculture. The features are conditioned by geographical factors. Status and perspectives of RES applications are conditioned by some specific features and factors, whereby it should be noted that location and climatic conditions are the most dominant factors. The solar, hydro and wind energy are in the main focus of the paper. Also, it will be presented the practical examples that are applied, or should be applied in Serbian agriculture. Some conclusions for further development are noted at the end of the paper.

Key words: *agriculture, crop production, livestock, renewable energy, solar power, wind power, hydro power*

Introduction

Historically speaking, the first serious contemplation about the possibility of using renewable energy sources (RES) dating as far back as 1916, and it is expressed in a comprehensive way by the famous engineer Thomas A. Edison: *"You see, we should make use of the forces of nature and should obtain all our power in this way. Sunshine is a form of energy, wind and sea currents are manifestations of this energy. Do we make use of them? Oh no! We burn forests and coal, like tenants burning down our front door for heating. We live like wild settlers and not as though these resources belong to us"* (Hubbard 2006). Starting from half of 19th century until today are predominantly present so-called "three waves of fossil years" as shown in Fig.1 (Staudt, 2009). Definitely, the future belongs to biomass, hydro, wind and other RES.

¹Mihajlo Pupin Institute, University of Belgrade, Robotics Laboratory, Volgina 15, Belgrade, Serbia, Corresponding author: Željko V. Despotović, PhD.E.E Associate Research Professor, zeljko.despotovic@pupin.rs, +381-11-6771024, +381-63-331645

Fig. 1. *Three waves of fossil years relate to actual trend of RES using*

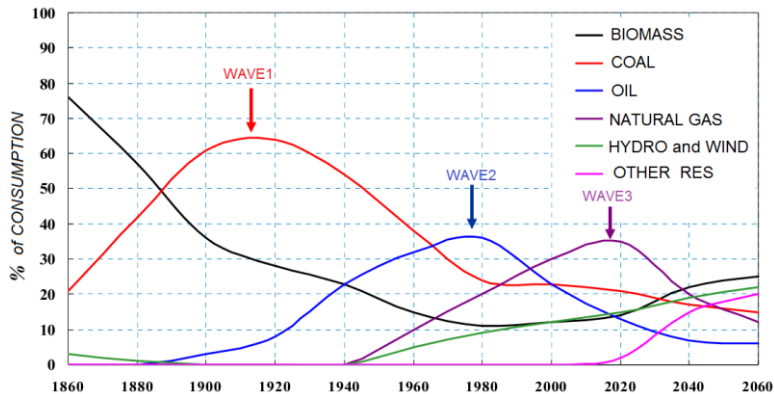

Under non-renewable energy sources we consider coal, oil, natural gas and nuclear energy. Coal, oil and natural gas are in fact fossil fuels and these energy resources are still the most dominant sources of energy. Two main problems of non-renewable energy sources are limited reserves, and environmental pollution. Combustion of fossil fuels releases large amounts of CO₂, which contributes to increasing the so called “greenhouse effect”. Nuclear fuels are not dangerous to the atmosphere, but nuclear waste remains radioactive for many years and must be stored in the objects of special purpose.

Fig. 2. *Current world ratio of RES relate to fossil fuels and nuclear energy*

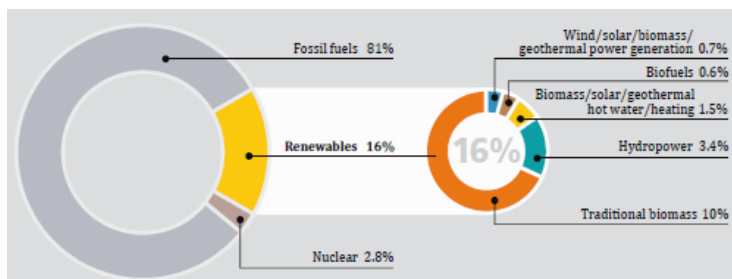

The current world ratio of RES in relation to non-RES is shown in Fig.2 (Sawin et al., 2011). It can be seen that the RES represent about 16% from the total amount. Within these 16%, the most amount of 10% include traditional biomass, hydropower 3.4%, biomass/solar/geothermal hot water/heating about 1.5%, wind/solar/geothermal power generation 0.7% , and bio fuels only 0.6%. Republic of Serbia, has estimated value of RES is about 4.3 millions “toe” (50000GWh) on annually level:

- Biomass 2.7Mtoe (31400GWh)-63% of the total potentials (1Mtoe- wood mass, rest 1.7Mtoe-agriculture mass)
- Solar energy about 0.6Mtoe (6978GWh)-14.5% of the total potentials
- Hydro potentials 0.5Mtoe (5815GWh) -14% of the total potentials
- Geothermal sources about 0.2Mtoe (2326GWh) - 4.5% of total potentials
- Wind energy about 0.2Mtoe (2326GWh)- 4.5% of total potentials

Note that the **1toe** = **1t** of **oil** equivalent is equal to amounts of 11630kWh. In terms of percentage distribution of renewable energy potential in the Republic of Serbia is given in Fig.3 (Banjac, 2012)

Fig. 3. *Percentage distribution of RES in Republic of Serbia*

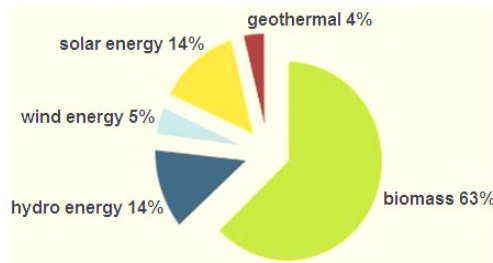

National regulations in the field of RES harmonized with Directive 2009/28 / E3 of the European Parliament and the Council on the promotion of the electricity produced from RES, and amending/repealing Directive 2001/77 / EC and 2003/30 / EC. The directive was partially transposed into national legislation by adopting Laws on Energy and of appropriate regulations (KEI 2016). The possibilities and scope of application of renewable energy in agricultural production of Republic of Serbia are determined by the following factors:

- Geographical position
- Natural resources (climate, soil and hydrological characteristics)
- Technical and technological level of development of the society
- Education level and ecological consciousness of the people
- The financial capabilities of the state
- Economic opportunities of family agricultural holdings

- Administrative and legal regulations in the use of natural resources
- Long-term global and European strategies for rural development and the fight against the negative effects of climate change.

Sources of biomass in Republic of Serbia

The potential for renewable energy contained in the biomass in Serbia has largely determined by arable lands, which are relatively unequally distributed, as shown in Fig.4 (Đajić, 2008).

Fig. 4. *The potentials of biomass RES in Republic of Serbia; arable land and areas under forests*

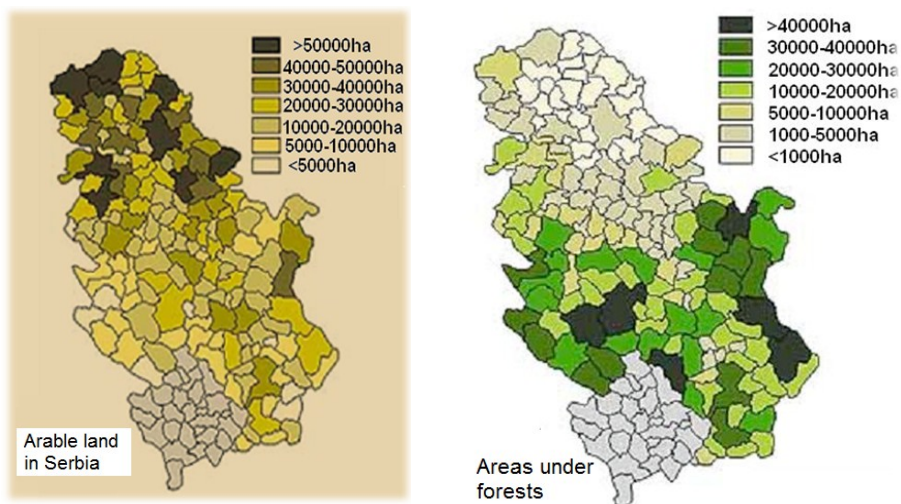

Total biomass energy potential in Serbia is estimated at 2.7Mtoe, primarily wood industry (about 1Mtoe), and remains in farming, animal husbandry, fruit growing, viticulture and primary processing of fruits (approximately 1.7Mtoe). The energy potential of biomass in livestock that is suitable for biogas production is estimated at 42ktoe. Also, large part of the Serbian economy is based on agriculture and the oriented agro-industry. The northern part of Serbia, province Vojvodina and territory along the rivers are the main areas of waste biomass sources. In addition to agricultural potentials, the Republic of Serbia belongs to the group of countries that are rich of forests. Around 30% of the territory is covered by forests and 55% of the territory is arable land. A significant part of area under forest is located in the southern, eastern and western parts of country.

Renewable energy of small hydropower plants in Republic of Serbia

Small hydropower plants (HPP) are power plants up to 10 MW and make a category of privileged energy producers. There are about 900 potential locations with a total capacity to 500MW with the possibility of production from 4600GWh for one year. This is 4.7% of total electricity production in Serbia or 15% of current electricity production in HPP in general (10900GWh for year). The distribution of HPP in Republic of Serbia is shown in Fig.5 (Đajić, 2008).

The energy potential of watercourses and locations for building small hydropower plants are estimated by the document: "*Katastar malih hidroelektrana na teritoriji SR Srbije van SAP*" from 1987, which is given to link:

<http://www.elektrosrbija.rs/me/images/dokumenti/Katastar%20MHE%20u%20Srbiji.pdf>

Fig. 5. *The potentials of small hydropower plants in Republic of Serbia*

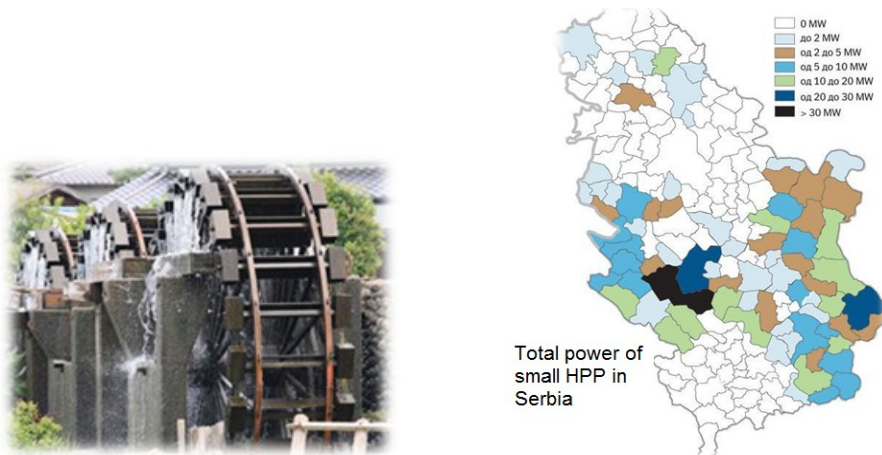

Exceptionally, it is possible to build such facilities in other locations with the approval of the Ministry of Mining and Energy concerning maximum utilization of the energy potential of watercourses and approval of other relevant ministries. The untapped hydropower potential in Republic of Serbia mostly is located in smaller rivers, so that the building of small HPP in the future can have the priority significance.

The potentials of solar energy in Republic of Serbia

The average solar radiation in Serbia is about 40% higher than the European average solar radiation. Unfortunately solar energy production is far behind the countries of the European Union. The number of sunny hours at the annual level in Republic of Serbia is more than 2000 hours. This value is higher than in most European countries, however, the solar potential is almost completely unexploited. For example, the annual total energy emitted by the Sun at average house roof per 1m^2 is equal to the energy obtained from burning 130liters of oil. At the same time, the fact is that this energy is completely free.

COMPARISON: The average value of global radiation at the annual level in the territory of Germany is about $1000\text{kWh}/\text{m}^2$, while in Republic of Serbia it is $1400\text{kWh}/\text{m}^2$.

Fig. 6. Global solar map in Republic of Serbia

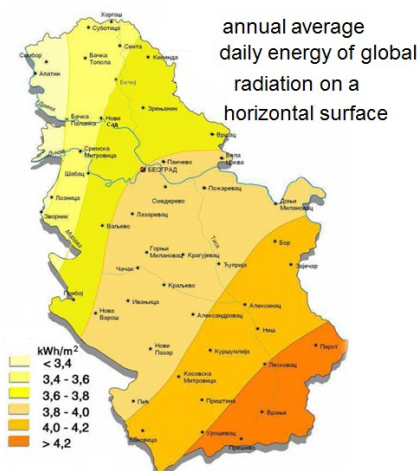

The areas in Serbia with a registered large number of sunny hours and acceptable annual ratio of real solar radiation makes about 50% of the territory as shown in Fig.6 (Gburčik et al., 2004).

As it can be seen, locations around Leskovac, Pirot, Vranje and Preševo are the most interest.

Especially should be noted that small solar collectors become more popular in households and farms for heating hot water.

The smallest collectors have an area of two square meters and are sufficient to heat water in a household or farm.

Electric power production from the photovoltaic (PV) panels is increasing. The installation potentials for Republic of Serbia are of about 30MW, with an average annual production of 1500-3000kWh/kW.

The potentials of wind energy in Republic of Serbia

Republic of Serbia possesses some suitable locations for wind energy production. Total potentials for wind energy production are about 1300MW and annual production capacity is around 2300GWh. The

average annual wind powers for locations of the Republic of Serbia are given in Fig.7(Gburčik et al., 2004). The very interesting are the eastern parts of Serbia i.e. mountains: Stara Planina, Ozren, Rtanj, Deli Jovan, Crni Vrh, etc. There are locations with an average wind speed over the 6 m/s.

Fig. 7. *Global average wind power in Republic of Serbia*

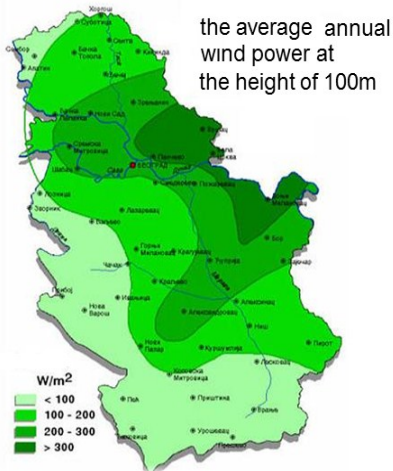

Zlatibor, Kopaonik, Divčibare are mountain areas where they would be able to determine suitable measurement locations for using of wind energy and applications of wind power stations. Pannonian plain, north area from the River Danube (Višac, Bela Crkva) are also rich of the wind energy. This area covers about 2000 square kilometers and it is suitable for wind energy applications.

The potentials of geothermal sources in Republic of Serbia

The Republic of Serbia has rich geothermal potential, but it is very little used. The potential of geothermal energy is amounted to 2300GWh per year (100 locations with sources). Over 50 locations have the potential greater than 1MW (Đajić, 2008). Greater use of geothermal energy would mean greater energy security and lower energy imports. In Republic of Serbia, the most developed geothermal area are in Vojvodina, and the areas with the highest water temperature are in Vranjska Banja, Jošanicka Banja, Sijerinska Banja, etc.

The possibility using RES in modern agriculture production

Taking into account the above (in the previous sections), first of all, natural resources and some limitations in the Republic of Serbia, there are very real opportunities for application of the following RES: energy from biomass, solar energy (photovoltaic and solar thermal), hydro energy of watercourses, geothermal energy and wind energy(Despotović, 2012). Modern agricultural production is characterized by the following features:

- High degree of flexibility in terms of business, which implies maximum mobility and transport (relocation)
- Economic and social sustainability,
- Environmental and health safety,
- Rational use of natural resources (land, water and energy) as part of their energy efficiency,
- The possibility of inclusion in European mainstream regional and rural development and environmental protection.

The specifics of agricultural production in Republic of Serbia could be briefly expressed through the following facts:

- Great fragmented plots
- In the structure of land holding dominate small and medium-sized agricultural households (average 3,5 hectare)
- Distributed of land holding
- Very low level of soil melioration
- The predominant extensive and relatively costly manufacturing
- A significant percentage of farmers like the traditional way without the use of modern agro-technical measures
- Insufficient training and informed of agricultural producers
- The low level of organization and professional association of farmers
- Small financial strength of individual producers
- Insufficient help the agricultural sector from the state
- The absence of significant state subsidies for the improvement of agricultural production
- The wealth of natural resources (land, water and natural sources of energy)

Biomass energy (plant and animal residues / waste in the production process) and geothermal (hot groundwater) are important natural energy resources but their exploitation requires great financial investments in the power-plant constructions. These plants are generally stationary type (usually built within the agricultural holding or near production facilities for processing raw materials). Taking into account the above features of the existing agricultural production on the one hand, and the abundance of natural resources on the other hand, the following three types of renewable energy are the most appropriate and most effective forms for use in agricultural practice in Serbia. Those are: (1) solar energy, (2) hydro energy and (3) wind energy.

Some practical realization and applications of RES in Serbian agriculture

A) Wind energy

Wind energy in the Republic of Serbia is not a significant source of energy that would be massively used in the whole territory. Wind potential has mainly in eastern areas of the country, along the valley of the Danube and region South Banat the so-called "Košava" region. It is well known that wind turbines are not economically viable if the average wind speed at a given location is not above 5m/s. Republic of Serbia has limited areas with such wind speed. Average wind speed for Serbia is 1.5-2m/s, and this is not enough for the sustainable use of these devices. The wind „Košava“ i.e *East wind* is the dominant wind at these locations and blows from November to March. Wind turbines are very sensitive to storm winds (> 80-100km/h) and then usually have to be mechanically braked. In spite of the foregoing, a small wind turbine (up to 1kW) could be used in locations of mountain passes or on embankments along the canals and river, on the edges of forests, etc. The disposition of horizontal wind turbine and their output characteristics are shown in Fig. 8. From the diagram in Fig.8 can be observed some basic characteristics for wind turbine/wind generator V600 (maximum output power 600W):

- Up to speed 3-4m /s, wind generator is practically insensitive
- Rated range of speed, 6-10m/s
- Over the speed of 20m/s (when the wind is very powerful) must be provided a mechanical braking

Fig. 8. The disposition and output power characteristics of wind generator V600

(http://www.vetrogeneratori.co.rs/vetrogenerator_v600.html)

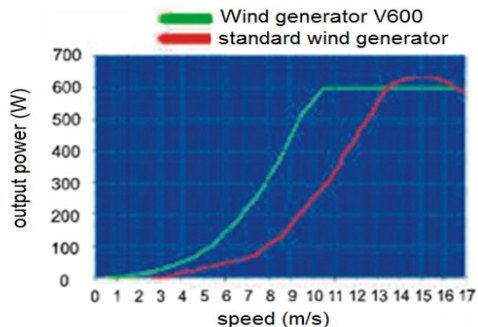

Fig. 9. *Mechanical support for vertical wind turbine*



Mihailo Pupin Institute, Robotics Laboratory analyzed different models of wind turbines. One of the solutions (designed by engineer Srđan Ćeramilac) is given in Fig.9. The advantage of this turbine is that the turbine wheel runs regardless of from which direction the wind blows, due to the specific shape of the blades. This turbine is harmless to birds and people. The output power is relatively small (about 200W) and can only be used as additional (not the main) source of the so-called hybrid systems applications: beekeeping and drip irrigation.

Special mechanical mobile support system has been developed (Fig.9) to provide mobility to this small wind turbine. The same implemented electronics enables connection of the wind turbine with solar generator, battery charger, battery bank and DC/AC power converter (inverter). Despite the many benefits offered by wind turbines, some disadvantages will be pointed out in the text below.

Wind turbines/generators that could be applied in the agriculture systems are practically useless at a height of 2-3m above ground level (wind velocity less than or equal to 2m/s). Also, they have a problem with the losses in the electric generator due to variations in the speed of rotation (due to the fact that the speed of the wind is very variable). The efficiency of these systems is relatively small (0.4-0.6). For example, in the vicinity city of Pančevo in South Banat, where there are significant airflow, “*water pump with drive on the wind*” are used, as shown in Fig.10. They are purely mechanical devices, they do not have the electrical components and can be very interesting in the so-called “*drop by drop*” i.e. drip irrigation systems.

Fig. 10. *Water pumps with drive on the wind*



Wind driven water pump „BANAT“ - by the inventor Bogdan Perišić, is applied in the South Banat (in Serbia).

- This piston driven water pump transforms rotary movement of airflow driven rotor blades into the linear movement by implemented mechanical gear.
- Typical daily values of water pumped into the appropriate tanks may amount to 6000-7000 liters.
- From the tanks (reservoirs), depending by the system (free fall or a small water pump), water is distributed to the crops and irrigate them.
- The cost of this type of water pump is about 3000Eu

B) Hydro energy

The prices for some MINI HYDRO TURBINE power from 1kW-10kW are quite reasonable on the market. Building small hydroelectric power plants requires a stable watercourse that does not dry up during the season. In the mountain regions, Serbia has the potential for use these types of renewable energy, especially as a power supply of mountain farms. Within this study, we want to point attention to an old patent that was reported in the 18th century in France and which becomes again actually, with a strong worldwide campaign to reduce pollution of the environment and to use renewable energy sources wherever it is possible. We are talking about original mechanical solution, water pump, which is popularly called "hydraulic ram" or water pump „teeter". The principal operation of system with "hydraulic ram" water pump is shown in Fig.11.

Fig. 11. Typical disposition of "hydraulic ram" water puming system

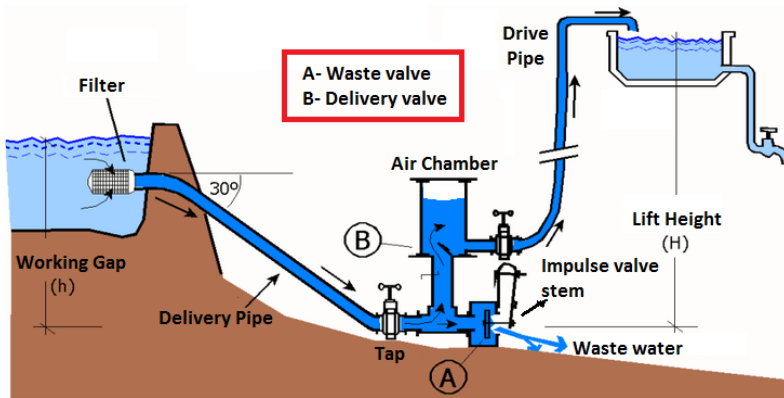

The hydraulic ram is a type of water pump that uses kinetic energy of water. It is ideal for use on the waterfalls or can be used in other water flows. It was named by the impact effect of water, which is used to sharply increase the pressure with which the water is pumped to a height greater than the height of the water flow. The height difference between the water flows, from which it takes the water pump, it should be higher, but it is not recommended more than 15 meters. The principle of operation is based on pressure changes (pulsations) of water produced in the closing inflow.

The device uses the kinetic energy of the water flow due to the height difference. Efficiency of this device is relatively low, less than 20%, however this device can operate non-stop as long as there is a flow. The device may be pumped by the water and the level of which is 3-12 times greater than the falling height of the watercourse. Because of its high performance and extremely low price and ease of maintenance, this device has excellent perspectives in mountainous areas where there are no built energy power infrastructures.

The device must be carefully and properly set up and when it is done once, this water pump can run for years without stopping highly reliable. This is one of the most economical solutions that can be applied for the use of RES and can be a valuable aid to agricultural holdings in mountain areas of Serbia, especially raspberry growers and growers of potatoes.

Also, this system can be used for watering systems drop-by-drop, according to the displayed Fig.12.

Fig. 12. Schematics of "hydraulic ram" pump powered with jain drip kit sourced through waterfall, (<http://www.jains.com/irrigation/drip%20kit/drip%20kit%20with%20hydraulic%20ram%20pump.htm>)

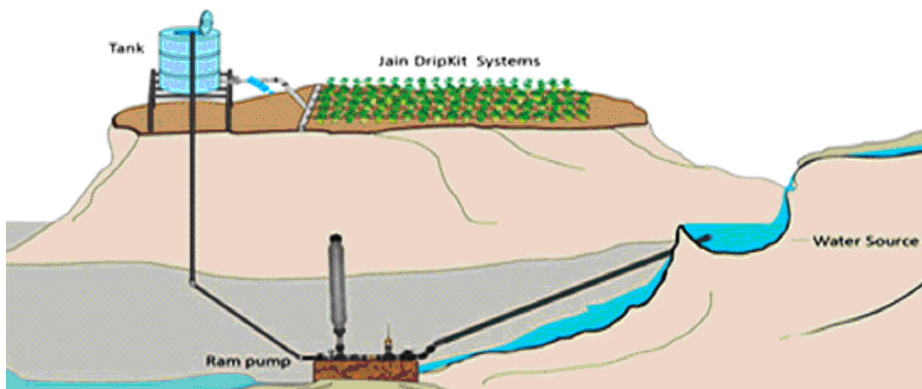

The prototype model of water pump "hydraulic ram", which draws water from a small river course (innovator Srebrn Stojanović, Leskovac) is shown in Fig.13. (<http://www.yourepeat.com/watch/?v=INLm073qhIA#!>)

Fig. 13. Prototype of "hydraulic ram" water pump applied in Serbia



C) Solar energy

In the Institute "Mihajlo Pupin" from Belgrade, in the Robotics Laboratory is developed a technical solution-industrial prototype of an

autonomous mobile solar generator (MSG). Two typical dispositions are given in Fig.14 (Rodic et al., 2014).

Fig. 14. Dispositions of autonomous mobile solar generator (MSG); close state (left), operating open state (right)



This technical solution has great potential in the application of environmental and clean energy technologies in crop and livestock production. Developed mobile device is an integrated system consisting of functional blocks as shown in Fig.15 (Despotović et al., 2015):

- (1) System of photovoltaic (PV) panels (3x300W)
- (2) Switch in PV circuit (turn on/ turn off)
- (3) Power converter (DC/DC solar charger with implemented *Maximum Power Point Tracking* (MPPT) algorithm)
- (4) Battery bank (24V/500Ah)
- (5) “DC link” terminal box
- (6) Mains power fast battery charger
- (7) Main breaker to DC side
- (8) Single phases output DC/AC power converter (voltage source inverter), 230V/50Hz, and 2.2kW

In addition to the displayed power electronics part of the MSG, this mobile device consists of very sophisticated sub-systems (Subić et al., 2016):

- for automatic two-axes tracking daily sun trajectory
- for supervisory and control
- very specific and flexible mechanical construction adapted to different purposes and applications as shown in Fig.18

The block scheme of measuring, control, and supervision sub-systems of MSG is shown in Fig.16 (Subić et al., 2016).

Fig. 15. Basic block scheme of power electronics system of MSG

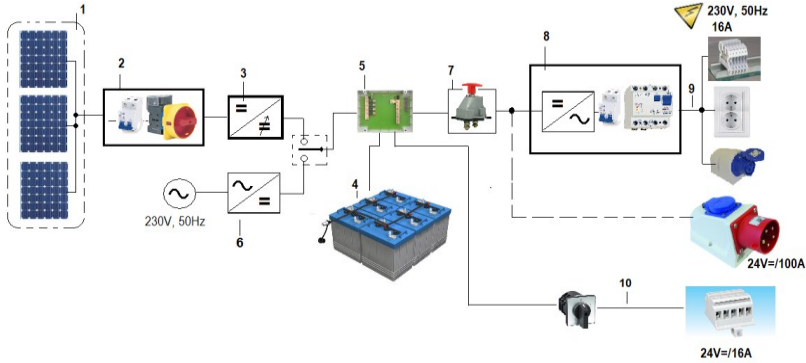
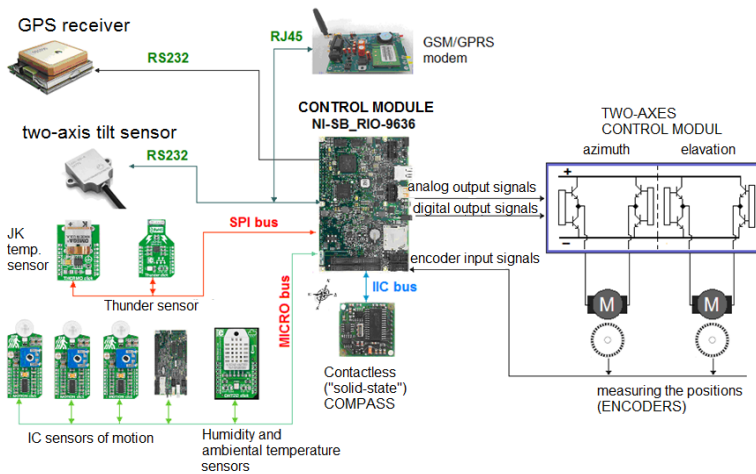

Fig. 16. Block scheme of measuring, control and supervision system of MSG



One of more significant optimizations in MSG are: (1) *the dual axis motion drive* and (2) *tracking of daily sun trajectory*. Chronological tracking (Fig.17) based on natural observation of the position of the sun in a given area and a given time period during the concrete day/month/year. This means that for certain geographic coordinates for a certain period of time the implemented software algorithm can determine the position of the sun during daylight. In accordance with the program can be controlled by the position of the solar panels throughout the day. This method of

positioning is independent of cloud cover because is known position of the sun at any time.

Fig. 17. *Principle of chronological tracking*

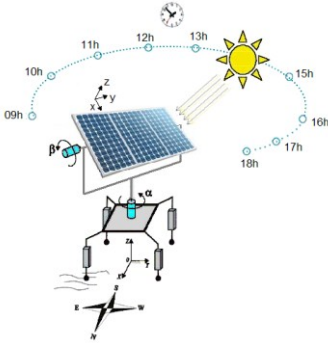
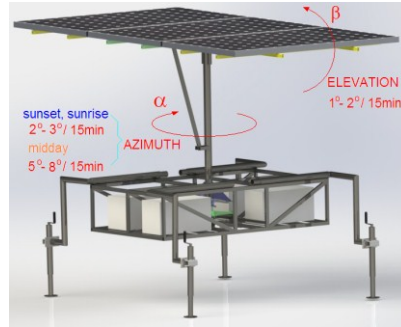

Fig. 18. *Disposition of dual axis motion drive*



The only thing that is needed to take into account is the orientation of the local coordinate system of solar panels refers to the global coordinate system i.e. “earth”. The dual axis motion drive is shown in reference (Stevanović et al., 2013). The range of azimuth and elevation angles-dual axis tracking are given in Fig.18. Assuming that the axis drives turning-on incorporate every 15 minutes to be at the beginning and at the end of the day (sunset / sunrise) had angular displacement α around 2° - 3° , a mid-day 5° - 8° azimuth, while the elevation of β jumps were milder than 1° - 2° . To accomplish this, we chose a system with two independent degrees of freedom (hence needs two actuators). MSG is universal device and can be used on any terrain where there is a need for electric power of (with DC voltage 12V/24VDC and with AC voltage 230V, 50/60Hz) and where conditions for the use of solar energy exist. They are ideal for use in agriculture as a portable, easy to use, reliable and robust in operation, requiring no special maintenance other than regular cleaning of panels from dust, the long service life (over 20 years), produce no noise and do not pollute the nature. They are recommended for use in both crop farming and fruit growing, as well as in animal husbandry, beekeeping, fishing, etc. Mobile solar generator as a solution for energy supply practically has no alternative in organic food production as it meets the strict environmental standards of production.

Application MSG in crop production

MSG is universal device which can be used for different purposes in agriculture. However, one of the most effective applications is in crops irrigation (on fields, orchards, etc.). Combined with electrically powered water pump, mobile solar generator can be used for irrigation of small to middle fields with area of several areas (greenhouses, hothouses, gardens) to several hectares (fields, orchards). In Fig.19 is shown the practical application of MSG with GSM remote control in crop productions (irrigation with water pump).

Fig. 19. *Application of MSG in crop irrigation*

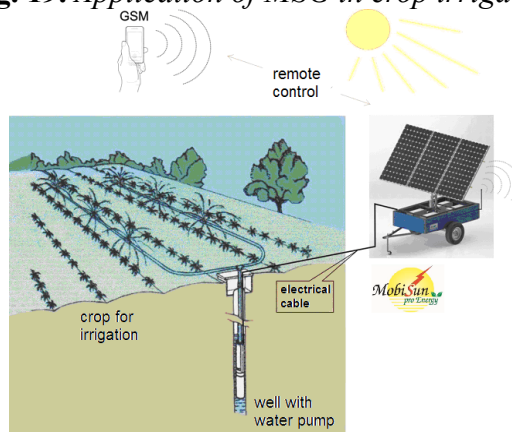

In Fig.20 are shown two possible application of remotely controlled MSG in drip irrigation system (with centrifugal pump) in combination with spraying irrigation system (with hand pump).

Fig. 20. *The operating principle of remotely controlled mobile solar generator (MSG) applied in irrigation of crops*

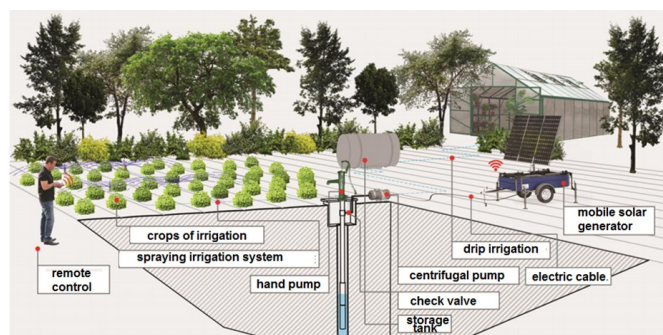

The comparative overview of the advantages and disadvantages of MSG in comparison to his competitive electrical gasoline aggregate (GA), is presented in Table I. GA unit has significant noise and emit the least CO₂. He also has significant fuel consumption and relative small lifetime (about 10 years). Opposite GA, MSG device, or electrical solar aggregate (SA), his silent operation, zero fuel consumption and zero emission of CO₂. Also, the lifetime is longer (about 20 years). The only advantage of GA is greater autonomy i.e. duration of continual operation (Despotović et al., 2016).

Table I - Comparison between gasoline aggregate (GA) and solar aggregate (SA)

Characteristics	GA	SA
Lifetime (years)	10	20
Duration of continual operation (h)	5-6	2-4
Fuel consumption (lit/h)	1.3	0
Noise	HIGH!!!	silent operation
Emission CO ₂	HIGH!!!!	-
Maintenance cost	moderately	low
Probability of failure	moderately	low

The practical application of MSG on the location for irrigation in the village Glogonj (Pančevo municipality) is shown in Fig.21.

Fig. 21. Disposition of the MSG; (a) in transport, (b) operating position in the cabbage plot, (c) pumping station, (d) pumping unit



The practical application of MSG on the location village Veliko Selo is shown in Fig.22.

Fig. 22. *Application MSG in location village-Veliko Selo; (a) in the courtyard of agricultural households;(b) greenhouses with garden tomatoes; (c) Villager 1500W garden pump connected to the irrigation system drop-by-drop;(d) pipe lines for irrigation system drop-by-drop*



Application MSG in animal husbandry

In terms of animal husbandry of mountain where there is no nearby power electric lines, can be mentioned mobile solar generator installed near stables (barns), fattening building, breeding station, station for watering livestock, waterholes, poultry farms etc., for lighting of stables, barns, use of automatic milking machines, feeders, power device "electric shepherd", the power of the refrigerator for storage of processed dairy and meat products, the use of other necessary tools etc. In this way can be practically expand the scope of work and raise a desired quality of production and hygienic quality of storage products. It is particularly interesting application in animal husbandry for solar power of air condition (maintaining the temperature during the summer, in the stables, where livestock stays, maintaining the temperature in the stables is essential for the quality of milk).

Fig. 23. Possible variants of applications MSG in livestock breeding; (a) mobile solar “electric shepherd”, (b) mobile solar station for watering livestock



Application in livestock and in case of inaccessible rural areas where it is not possible to provide continuous supply with electric power. In Fig.23 (Despotović et al., 2016) are shown the possible applications MSG in livestock breeding. In Fig.23(a) is shown the “*electric shepherd*”, and in Fig.23(b) is shown the mobile solar stations with MSG for watering of livestock.

Conclusions

The energy needs for a large number of activities within a multifunctional agriculture are possible to obtain from renewable energy sources (such as solar, hydro and wind energy), which would substitute, widely used fossil fuels. The objectives of this study are consistent with all relevant national legislation in the field of promoting and supporting the pronounced use of renewable energy in the agriculture sector. It also made a brief overview of the possibilities of application of RES in Serbia and outlines some good practices that have been implemented in Serbian agriculture. In this paper, it is represented only one part of the research, which is significantly greater extent given in the following projects:

1. Innovation research and development project entitled “*Development of remote-controlled robotic mobile solar electric generators for the improvement of agricultural production*”, under document number 451-03-2802 / 2013-16 / 55 for a period of 01.06.2014. to 31.05.2015., funded by the Ministry of Education, Science and Education and Technological Development of Republic of Serbia.
2. Project: “*Techno-economic analysis of the use of renewable energy sources and mobile robotic solar electrical generator in agriculture*”, funded

by the Ministry of Agriculture and Environment of the Republic of Serbia, approved with the decision no. 401-00-1683 / 3 / 2014-03 from 28.07. to 28.10. 2015.

3. Project: *"Socio-economic and environmental aspects of the use of renewable energy sources in agricultural production in the Republic of Serbia"*, financed by the Ministry of Agriculture and Environment of the Republic of Serbia, no. 680-00-0031 / 2016-02 from 18.08. to 30.11.2016.

References

1. Banjac, M., "Budućnost energetskog sektora Srbije", Životna sredina i energetika – Šta čeka Srbiju, 2.Mart 2012, Hotel Hyatt, 2012
2. Despotović, Ž.V, Rodić, A., Stevanović, I., Jovanović M., Popić, S., "Primena mobilnog robotizovanog solarnog generatora u novim ekološkim tehnologijama u poljoprivredi", Zbornik radova I savetovanja sa međunarodnim učešćem INFORMACIONE TEHNOLOGIJE, RAZVOJ I PRIMENA U UNAPREĐENJU ŽIVOTNE SREDINE IT EKO 2015, Beograd 07-08.12.2015, Vol1, No1, pp.15-25, ISBN978-86- 80464-00-8, Beograd, 2015
3. Despotović, Ž.V, Jovanović, M.D., Stevanović, I., "Primena mobilnih solarnih jedinica u ratarstvu i stočarstvu", Zbornik radova - IV Sajam Energetske Efikasnosti i Obnovljivih izvora energije, Vol.1, pp. 11-26, ISBN 978-86-916839-3-1, Požarevac, 2016.
4. Despotović, Ž.V, "Obnovljivi izvori energije-stanje i perspective u Svetu i u Srbiji, INFO dani, Beograd, April 2012.
https://www.schrack.rs/fileadmin/f/rs/pictures/company-contact/events/Schrack_Info_dani/Prezentacije/Dr_ZeljkoDespotovic_Info_dani_april_2012_SCHRACK.pdf
5. Đajić, N., OBNOVLJIVI IZVORI -STANJE I RAZVOJ U SRBIJI 2008
<http://www.energoportal.info/stranice/obnovljivi%20izvori/OIE%20-%20STANJE%20I%20RAZVOJ.pdf>.
6. Grubčik, P.(et al.), "Studija energetskog potencijala Srbije za korišćenje Sunčevog zračenja i energije vetra", (NPEE, Evidencioni broj EE 704-1052A), Beograd, Novembar 2004, Institut za multidisciplinarna

istraživanja (Centar za multidisciplinarne studije do 2008), Univerzitet u Beogradu,

http://vetar-sunce.imsi.rs/tekstovi/Studija_EE704-1052A/

7. Hubbard, E., "Edison on renewables", April 2006,
<http://www.resilience.org/stories/2006-04-13/edison-renewables/>
8. Rodic, A., Despotovic, Z.V., Jovanovic, M.D., Popic S., Stevanovic I., "MOBILE ROBOTIC SOLAR GENERATOR MobiSunProEnergy™-APPLICATION IN NEW ENERGY TECHNOLOGIES", VIII International Forum for Clean Energy Technologies 2014 ENERGY CHARTER = SUSTAINABLE DEVELOPMENT OF SERBIA, Novi Sad, 30th September – 1st October 2014
<http://www.ktt.uns.ac.rs/reec/FORUM%202014/dan%202/02.5DespotovicIMP.pdf>
9. Sawin, L.J, (et al.), REN 21 Renewables 2011 GLOBAL STATUS REPORT, 2011.
10. Stevanović, I., Popić, S., Rodić, A., Despotović, Ž.V., Jovanović, M.D, "Pokretni robotizovani solarni generator, primer konstruktivnog rešenja mehaničke strukture", 57, Konferencija ETRAN 2013, Zlatibor, 3-6. Jun 2013.
11. Stoeckl I., "Introduction to Renewable Energy Sources", Jul 9, 2002,
<http://www.tigweb.org/youth-edia/panorama/article.html?ContentID=452>
12. Staudt, L., "Assisting the World's Transition to a Sustainable Energy Future", Centre for Renewable Energy, Dundalk Institute of Technology, Ireland, 13th International Conference of the International Environment Forum, Washington, D.C., USA, 13-16 August 2009
<https://iefworld.org/dStaudt09.html>
13. Subić, J., Jovanović, M., Despotović, Ž.V, Jeločnik, M., "Possibilities of applying robotic systems and smart sensor networks in integral agricultural apple production", Advances in Robot Design and Intelligent Control, SPRINGER, Robotics in Alpe-Adria-Danube Region (RAAD16), Vol.540, Chapter 30, pp.269-285, ISBN 978-3-319-49058-8, Available at November 2016
<http://www.springer.com/la/book/9783319490571>

I SECTION

***TECHNICAL AND TECHNOLOGICAL
PROGRESS AND THE SUSTAINABLE
MANAGEMENT OF RESOURCES
IN AGRICULTURE***

HUMAN RESOURCE MANAGEMENT IN BUSINESS SYSTEM OF INFORMATION TECHNOLOGY

Dragić Živković¹, Đina Đekić²

Abstract

This paper presents an enterprise, that is business system, whose activities are focused on information technology. The company is organized as a limited liability company, specializing in IT and communication engineering. Performs a variety of tasks related to information systems, software products, computer networks, hardware / software support and training, on the territory of the Republic of Serbia and abroad (countries in the region). In a global business where changes occur on a daily basis and where the struggle for survival occurs in the market, corporations must have employees viewed as long-term investments to help achieve competitive advantage in the market and increase profitability of the business in whole. Since the staff is a key factor in the socio-economic development, the ultimate goal is to present in the paper a model of human resource management in the business system (company) of information technology.

Keywords: *human resources, planning and recruitment, selection and training, rewarding and leaving the organization.*

Introduction

Human resources with their knowledge, skills, work habits and professional experience in qualitative and quantitative sense have impact on the productive capacity of the company, and in that way, they are the most important factors of the organization and business performance. Therefore, the aim of every company, through constant development and training of its employees, is to achieve their own growth and take the leading position in the market.

¹ Dragić Živković, PHD, Faculty of Agriculture, University of Belgrade, Nemanjina street no 6, 11080 Zemun, telephone +381112615315, ext 425

² Đina Đekić, MSc, Faculty of Agriculture, University of Belgrade, Nemanjina street no 6, 11080 Zemun, telephone +381658019787, E-mail: djinadjekic@hotmail.com

The observed company is one of the oldest domestic IT companies, which was founded in 1989 with the aim to provide users of computer systems quality support and access to the latest information technologies. It is headquartered in Belgrade, with its own building of 1,500 m², and with sales - service centers located in Novi Sad, Nis, Podgorica and Banja Luka.

Its current position in the market the company has acquired, primarily thanks to the service quality and completeness of their offers. This is confirmed by numerous awards at official events, and the fact that some world-renowned companies are interested in establishing cooperation with this company such as HP, ORACLE, MICROSOFT, CISCO SYSTEMS, Fujitsu and others. Users of the service provided by the company are successful companies in various fields of economy (agriculture, industry, banking ...) such as Hemofarm, GSP, Dairy Sabac, Plantations 13. jul Montenegro, Telenor, Telekom Serbia and others.

The company's business includes the design, development and implementation of information systems, using the latest products and tools; computer programming and consulting; sale of ICT equipment and ICT solutions; servicing of ICT equipment; repair of computers and communication equipment; installation and maintenance of computer equipment during the warranty and after guarantee term; design, installation and maintenance of computer networks; education and training of customers and final users in their own training center; SLA (after sale hw / sw support). The company owns a variety of facilities, premises, equipment like equipment for measuring and monitoring, transport and communication equipment.

The Company has developed and integrated management system (IMS), and it has also implemented and applied management system that meets the requirements of ISO 9001: 2008 standards for the following areas of activity: sales of equipment and ICT solutions, service of ICT equipment, software engineering and education of customers.

The company owns all the certificates necessary for the performance of original activities, and also regularly performs internal audits of compatibility, according to the requirements of ISO 9001: 2008, ISO 14001: 2005, OHSAS 18001: 2008, ISO 27001: 2013 and ISO 20000-1: 2011 and according to the account for internal audit.

Working methods and data sources

To see the detailed process of managing human resources in observed company, the following methods are used: analysis and synthesis, induction and deduction methods, methods of observation, description method, abstraction, statistical methods, tests, interviews and similar. Versatile consideration of the subject of research was possible thanks to various sources of data used in this study, such as the professional literature of domestic and foreign authors, direct communication with the manager, manager of human resources and employees, the company documentation, adequate legislation and search of the web site.

The organizational structure of the observed company is the shape of grouping and networking activities, material and labour resources and the establishment of connections and relationships between them and within them.

The organizational structure of the company is functional and consists of four departments, and they are: marketing, production and service, finance and legal affairs.

Every employee of the company has rights but also responsibilities, in proportion to the position of the work done. Job description for each position is defined in the Regulation of job classification.

With this established organizational structure and relationships between employees and those who manage, it is ensured and verified the quality of products and processes and the IMS as well as their independence and authority necessary to achieve the set tasks.

The significance, goals, process and models of human resource planning

Modern management of human resources is a specific multidisciplinary, social science that studies all aspects of employment in the society. People with their knowledge, skills, experience, energy and enthusiasm are the driving force of every company. Human resources are a living organism that has the ability to sustain its constant development through the acquisition of new knowledge and skills, and thus their significance as a durable source of competitive advantage is even more highlighted. Human resource management is a management activity that involves security, development, maintenance, guidance and use of human resources in line with the objectives of the company.

The analysis of human resources in observed company implies employees structure, i.e. the analysis of labour force according to sectors in which they work, and according to qualifications, length of service, by age and by gender. Out of total number of employees 49,25% are in software engineering, 20,90% are in service, the rest 29,85% are placed in others organizational units of the company. Faculty diploma has 63% of employees, 33% has high school diploma. The rest of the workers has college degrees. Some employees are with the company since its foundation, 40% of employees has more than 20 years of service. Junior employees and workers nearing retirement make 12% of total manpower. Company employs 42 men and 26 women.

Human resource management includes the managing measures and activities which provide, develop, adapt and promote the knowledge, skills, abilities and other potential of employees for their optimal utilization and realization of individual and organizational goals. Holders of the functions of human resource management in the organization, belong to all levels of management.

Observed company has got no service for human resources, but in each organizational unit, one employee in addition to the functions that requires his job, performs the functions of human resources manager and this person is the managers in charge of human resources management at the level of his organizational units.

All of the above is preceded by human resource planning as a process by which the human resources, needed for the company, are planned and strategies are made for their provision, and it is based on the belief that they and their staff resources are the most important strategic resource of the organization.³ Human resource planning involves bringing the right people at the right place and at the right time, and can be physical - the number of individuals that is required and the individual – the number of individuals required for important positions in the company. Observed company has used a model of integrated planning.

It is necessary in the planning of human resources to anticipate demand for manpower, which should reply the question of how many employees

³ Mića Jovanovic Božinov, PHD, Kulić Zivko, PHD and Cvetkovski Tatjana, PHD (2008): Fundamentals of Human Resource Management, Megatrend University, Belgrade, page 44.

and which professions will be needed in order to achieve the set goals. In the observed company, forecasting for the demand for human resource management is done using objective methods, which means to carry out an analysis of internal conditions (on the basis of business plans, available employment, rates of employee turnover, etc.) and external conditions (state of the market, new technologies, political and economic situation, competition, etc.).

Prediction of internal supply of human resources, applies to all employees in the company and is carried out using the following methods:

1. Annual staff turnover index shows the percentage of how many workers left the company in one year and is calculated by the following formula:

(the number of employees who leave a job in one year / average number of employees on duty during the year) x 100 = rate of decreasing the number of employees in percentage, in this case it is $4/67 \times 100 = 5.97\%$ of the workers, of the total number of employees who left the company during the year.

2. Stability Index shows the number of persons who are able to remain at work during a period of time, not counting persons who were employed during the year and not taking into account the length of service. This index is calculated as follows:

(Number of employees with annual work / number of employees the previous year) x 100 = stability expressed as a percentage, which in this case is $67/68 \times 100 = 98.53\%$ and indicates that in this company stability in terms of changes in the number of employees in the reporting period is on a high level.

The recruitment, selection and socialization of new employees

Recruitment involves the attracting of a larger number of candidates than the number to be recruited, so managers, who carry out the final selection, could choose those that best suit the needs of enterprises. The methods of recruitment of human resources are: internal and external recruitment.

Internal recruitment involves a search for potential candidates in the company. The main internal sources of recruitment are: improving the staff, their transfer to other positions and rotating tasks between employees of a temporary nature.

External recruiting means that the potential candidates are recruited from the labour market, and its methods are: advertising, cooperation with employment agencies, recruitment through schools and colleges.

Observed company carries on recruiting of new candidates in accordance with the planned volume of business, staff turnover, layoffs of employees who did not meet their basic tasks and the like. The most commonly applied external recruitment is through advertising, through the faculty or by using the services of employment agencies. Internal recruitment in the company means periodically upgrading of existing employees.

Candidate selection is the process that determines the quality of the applicants and on the basis of the results it is obtained their selection to recruitment. Selection consists of the following steps: log in to the job and sending a Curriculum Vitae (CV); testing of the candidate; interviewing; checking the documentation and recommendations; the offer of work; decision on employment.

The selection criteria can be defined as a sort of standards that the candidate must meet in order to get the job. There are three selection criteria and these are: organizational criteria - which assesses certain characteristics of workers on the basis of estimating their performance; functional or ward criteria - involves defining the appropriate interpersonal skills of all members of the Department of Human Resources; criteria for certain jobs - which are carried out on the basis of a job analysis.

The most significant method, that is, instruments for the collection of biographical data on the candidates, are: application forms for biography (CV); forms for collecting biographical data; tests of biographical data with even more extensive and detailed information about potential candidates; tests - as measuring instruments by which people are compared at a certain characteristic that is the subject of measurement and testing; group methods - mainly applied for management positions; centres for assessment - are used to measure how well the candidates would act in managerial positions.

In the observed company, selection process is carried out by executives / managers of human resources and director of the company and they use the following methods in the following order: application forms for biographies (CV) with which it is desirable to attach a cover letter, a

knowledge test and an interview. When selecting the candidate the most important to them is education, although work experience plays an important role, and then communication skills, nice and neat appearance, commitment, team spirit and similar.

The company points out that they have been long without the candidates who took the test without error knowledge. Sometimes they tests also the practical work on the computer, as well as knowledge of English.

The interview is the most commonly used method of selection. It implies an oral interview of two or more persons organized for better understanding of the candidates, and especially their social skills that are difficult to spot in other ways, such as: communication skills, persuasiveness, self-confidence, appearance, and similar. The criteria according to which the interviews were divided are: degree structure (unstructured, semi-structured and structured interview); scoring (the examiners receive the key by which candidate responses will be scored); number of persons conducting the interview (individual, team, and panel interview).

In observed company after receiving and analyzing the biography for a job, the best twenty candidates are invited to the opening test, and then based on the results of the test, ten of them remain in the race for the vacant position and are invited for an interview. It is implemented by human resources manager of the sector for which the candidate has applied and manager of human resources, that is Head manager of another sector and in some cases, the director. They have a template frequently asked questions, and complete freedom to introduce a new issue, then they can use the semi-structured interview panel. After completion of all interviews of candidates, a decision is made who is the best candidate for a given position. Then again a meeting with the selected candidate whereby he is given a job offer. If the candidate accepts the offer, he is accepted on probation for a period between one month and one year, depending on its ability to adapt. When a candidate demonstrates that he is capable of performing operations independently, he will be offered to sign the employment contract for an indefinite period.

Socialization of new employees is a process in which the newly employed person is introduced into the business and meets the organization of the company, and includes the following activities: candidate introduction with rules of conduct, working conditions, colleagues, organizational culture, development plans, rights, duties and responsibilities at work and

similar. In observed company the most important role in the process of socialization of new employees has a sector manager and other employees whose role is to create such a working environment in which new employees will feel comfortable and important at any time, and will feel affection and belonging to the collective.

Training (training), evaluation of the quality of training, expected performance and development, and management of staff career

Training of employees is one of the very important part of the work of HR departments and includes changes in specific knowledge, abilities, skills, attitudes or behaviour of employees in order to enable them as soon as possible for quality performance of the current job. It is needed in order to carry out work efficiently and effectively and that the company adapt to changes in the environment to their employees trained in accordance with the requirements of the market. Within the company, the training can be organized at the level of the entire company, department or individual level.

Training needs are most likely to occur when: hire a new employee, change the method and conditions of work, the worker is moved or improved. Identifying training needs takes place on three levels such as: the organizational level, the level of the workplace and the individual level. In practice, there are five models to organize the training activities of employees, and they are: functional mode, the customer model, matrix model, a model of corporate universities and training model of a virtual organization.

In the analyzed company, identification of training needs is done at the organizational level and at the level of the workplace, and applies to functional model and sometimes a virtual model of training. Training is conducted by employees of the company, the managers of individual sectors and director, and is usually implemented through specialized certification centers such as Prometric, Pearson, CPU, and similar. The training can be organized in the premises of the company, leased premises, in specialized centers or virtually, which means that employees can be at home to monitor training via computer. The training is organized during working hours, and in his spare time of employees, depending on the type and severity of the training availability of devices that are used for training and similar. All training costs are on the company.

All employees, in the beginning, must pass QMS (Quality Management System) training and then technical training in a certain position. After successfully held training, the lecturer is obliged to write a record of the training, which will show basic information, such as training topics, time and place, students and similar. Such conducted training allows the company to monitor the market and technological changes in order to improve their own position in relation to the competition.

Human resources manager of a certain sector regularly monitors key parameters (KPI) in the company, which include: the percentage of renewed contracts, the percentage of complaints, the percentage of solved problems from the start, the percentage in which the response time was not fulfilled and an overall assessment. With the analysis of these parameters it is determined whether in the observed period, planned standards are fulfilled or not and the reasons contributed to this result.

A worker who has been nominated for training, is addressed to the person who carries it out, and after completing the course, goes to the certification center with which the company cooperates, for example, CPU, for passing the test and taking the certificate. The test is graded on a computer, under the watchful eye of the controller and camera that records all of candidates, after which the candidate will receive the appropriate certificate.

Evaluation of employee training is a process in which on the basis of the collected data, the results are compared with the expected goals. The aim of the evaluation is to determine whether the training was useful for the company and employees, and what effects will have on business operations of the company.

In order to achieve the defined objectives, each company conducts performance evaluation of employees, which can be understood as a process of organized and continuous monitoring, assessment, guidance and adjustment of performance and work behaviour of employees. This process is based on specific methods, criteria and evaluation systems. Basic types of information about the performance of the employees are: personal characteristics of employees, employee behaviour and results. The most commonly used six basic dimensions of work, which may be the subject of assessment, are: quality, quantity, respect of deadlines, cost-effectiveness, the need for supervision and coaching and interpersonal impact. The observed company performs regular assessment

of the performance of those employees, but most attention is paid to: quantity, quality, respect for deadlines and cost efficiency.

The evaluation of the performance of employees shall be based on two main methods which are: objective and subjective methods. The evaluation of performance is performed by the observed company on a monthly basis for employees in production and semi-annually for employees in sales, service and school centers. Rating is done at sector by the head of the same, and evaluating in the level of the whole company by director, using a combination of subjective and objective methods. An instrument that is used in this process is the scale of imposed distribution. Validity, reliability and freedom of prejudice are the criteria used for evaluation of the quality assessment of employees in the company. After completion of the evaluation process, corrective actions are performed and ways to improve the performance are identified of both individuals and the organization as a whole.

Observed company invests in the development of their employees, because except they are the "soul" of the company, they represent its significant capital. In developing employees it uses: the traditional model, evaluation of the development potential of employees through a standard model for comparison and also a model of work experience.

Interpersonal relations are reflected in the fact that a director or manager of the sector take on the role of mentor and their knowledge and practical experience is transferred to employees.

Career is a development of an individual in learning and working throughout the life. The goal of career development is to link the needs, knowledge and skills of employees with current and future needs of the company. There are two methods of planning a career and they are: organizational mode where the company's management plans the goals of employees and individual way, where an individual is planning to set goals of his career. Career management is the process by which a company selects, evaluates, deploys and develops employees to ensure the required number of qualified people to meet their future needs. In the analyzed company organizational career management is accomplished through the chief executive and human resources managers. They are a key factor in linking individual needs and ambitions regarding career development with organizational needs and goals.

The system of wages and elements of earnings (wages)

Rewarding of employees is the most complex and the most visible element of human resource management, considering the fact that earnings are of great importance for both employers and workers. The system of compensation includes all tangible and intangible rewards that the organization assigns to employees. Salary system applies to all tangible rewards that the employer provides to employees in exchange for the work. Salary system consists of: direct part (refer to the fixed salary and a variable component that depends on the performance of the employee) and indirect part (relating to protection programs, paid leave and various benefits).

Elements of the salary, which is composed of variable and fixed elements, are: the basic cost of labour (minimum wage), allowance (supplements for the qualification and similar), benefits (cash value which the worker receives additionally, such as lunch vouchers, discount for shopping, etc.), premium (fee for the unusual working time), overtime (variable element which is paid more than the usual price of labour), stimulant (related to achieved results) and bonus (the worker is not entitled to the bonus under the contract and is not guaranteed, for example, a bonus for the Christmas holidays).

Cash earnings in the observed company are confidential and are different according to the position and years of work. Elements of salaries of employees of the company are: the basic wage, benefits, bonuses, overtime and bonus.

When it comes to motivation and leadership aspect, it should be noted that the role of the main leaders in this company has a director of the company that employees follow. He seeks to lead its sectors as team management with a high degree of interest in people and sales. Beside him leadership roles have heads of organizational units who are familiar with the needs and motivations of employees in the sector and work towards maximizing motivation. The leaders of the company perform analyzes of its employees in order to complete what motivates them to work (adequate salaries, other awards, praise, teamwork and positive working atmosphere, a sense of belonging, etc.).

Labour relations and collective bargaining and union organization of employees

In all countries of the world, the area of labour relations is regulated by legislation, which defines the rights and obligations of employees and prevents discrimination. The basis of the law governing the different areas of labour and employment relations in Serbia, the Labour Law, was published in 2005, and last amended in 2014.

The provisions of this Act shall apply to all employees in the private and public sectors, as well as to employees who are foreign citizens and stateless persons who work with the employer in the territory of the Republic of Serbia, unless otherwise specified.

Employment is based on the signing of the employment contract between the employer and the employee, and mandatory elements are: name and seat of the employer, name of employee, employee qualifications, job description, place of work, duration of the contract, the date of commencement of work, wages, vacation, paid leave.

Trade unions, in terms of the Labour Act, are independent, and democratic organizations of employees to which they voluntarily associate to represent, introduce, promote and protect their professional, labour, economic, social, cultural and other individual and collective interests. The protection of the rights and interests of the union should be used peacefully, admissibly and by democratic means, not with inadmissible and non-peaceful means of labour struggle.

The observed company, on the basis of employment contract and the Rules of Procedure, governs the labour relations of the employees. In the company there is no union, there are no plans for its organization in the future. Employees are satisfied with salary and working conditions, so that their trade union involvement is not interesting. As there is no trade union organization, there is no possibility of collective bargaining and making a collective agreement.

Health, safety, employee welfare, discipline and appeal procedures

The right to safety and protection of life and health belong to all employees in accordance with the law and general act. Certain categories of employees have special protection in accordance with the law.

Safety and health at work is the provision of such working conditions which, as much as possible, reduce injuries, occupational diseases and diseases related to work which predominantly create presuppositions for full physical, mental and social wellbeing of employees.⁴

The observed company operates in accordance with all relevant laws and each employee is obliged to pass a variety of training, including training on safety and health at work, fire prevention and others. Also, the company takes care of the general welfare and well-being of employees, so they are paid on time, provides the best possible conditions for work and ensures that the working atmosphere is positive, team and motivating. So far there have been no cases of criminal and civil cases in the companies.

From the perspective of the reorganization of positive health program, the company takes seriously the health of their employees and in many ways supports the campaign against smoking and provides free recreation for their employees. It also helps in solving serious health problems, so a few times it helped financially to treat their workers abroad (Italy), thus putting human life above all economic calculations.

Discipline is the regulation of human activities in order to achieve results. There are managerial, teamwork and self-discipline. The observed company has implemented team discipline. There are following rules that apply to different types of behaviour: negligence - when the employee does not perform the job properly; uncertainty - failure to attend work as specified; disobedience - refusal of the set of instructions for carrying out the assignment; endangering of the other rules; theft; violation of safety. Forms of punishment are: warning, drawing attention, warnings, disciplinary move, suspensions and fines.

The complaint is a claim which is formally presented to the manager, dissatisfaction is all that disturbs the employee, but a complaint has expressed dissatisfaction of the employee in writing. This is not recorded complaint and appeal of employees, but it happened that employees receive verbal warning because of delays in the work, as well as fines (10 to 30% of salary) for haughtiness according to official vehicles and made financial loss. Disciplinary remove happened only once.

⁴ Law on Safety and Health at Work ("Off. Gazette of RS", no. 101/2005 and 91/2015)

Retention of staff, leaving the company and measures to promote human resources

The goal of human resource management is to keep existing high quality staff with the help of tangible and intangible rewards, promotions and similar. The reasons why employees voluntarily leave the company are: outer factors, functional crafts, rejection factors and attraction factors. Observed company is trying to keep their employees with the help of high salaries for our conditions, good working conditions, a positive working atmosphere and care for employees.

The most common reasons for voluntarily leaving the company by employees were: relocation abroad, moving to another city, state of health workers, discontent hours (night duty - especially during the holidays), dissatisfaction with the job description (for example, in sales, a lot of time to carried out in the way), inability to fit in the team, and similar.

Termination of the contract is carried out on the basis of three forms: unlawful dismissal - when it violates the employment contract; constructive dismissal - the situation when an employee is forced to quit; unfair dismissal - based on gender, religious confession, disability, pregnancy or maternity, etc. In this company there were no such release.

Forms of leaving the company are: willingly leave of the employee - breach of contract by the employee and retirement; reluctant leave of the company by the employer firing an employee can happen for failing to fulfil tasks and dismissal as redundant. The willing leave of the company came mainly due to retirement (fulfilment of legal requirements), and there were involuntary departure (meet age criteria and achieved years of service).

Forms of pensions are: state pension scheme, schemes with defined benefits, defined-contribution schemes, combined schemes, personal pension and retirement shareholding. In the analyzed company employees are paid a standard amount to the basic state scheme. Since founding the company, five people were retired.

The company has serious plans concerning the improvement of human resources. It is planned to establish the sector of human resources which will include human resource managers, coordinators for salaries and benefits, and two administrators, who will deal with personnel matters at the level of the whole company. This will reduce the workload of managers

of organizational units, the analysis of jobs will be better, as well as planning of personnel and recruitment process which will be more efficient, more economical, bigger commitment and care for employees with a view to their development will exist and also health and safety, fair system of remuneration of employees and other effects significant for the development and the success of the company.

Because of all this, the company annually conducts an anonymous survey of employee satisfaction, and plans to do like this on a monthly basis. Also, it plans an involvement of psychologists in the process of selection of candidates, followed by the introduction of team interviews and similar.

Conclusion

Analyzed company was founded in 1989, and it consists of 4 sectors and 67 workers deployed by organizational units. Most people work in software engineering.

Within the company, there is a separate sector for human resources at the company as a whole, but each organizational unit has one employee (usually the Head of the office) appointed to carry out the duties of manager, although the plan is to establish this sector and to carry out its implementation.

Annual trade index in the company is 5.97%, a stability index is 98.53%, and it can be concluded that the company is very stable in terms of brain drain. The company also carries out human resources planning, using the model of integrated planning and forecasting of demand for human resources is carried out through an objective prediction methods. The recruitment of human resources is done internally by improving existing employees and externally through advertising, colleges and employment agencies. Initial selection takes place on the basis of applications and CV's of candidates, and it is performed by the executives and the CEO through the introductory testing, interview on the scheduled meeting, checking the accompanying documents and recommendations, offering work and signing a contract of employment.

The identification of training needs is done at the organizational level and at the level of the workplace, and uses a functional model and sometimes a virtual model of training. Training is usually conducted by the executives, senior colleagues or director personally, and training costs are born by the company.

The performance of employees in manufacturing are evaluated every month, while employees in other business segments are evaluated twice during the year. When evaluating performance, the greatest attention is paid to the quantity, quality, respect for deadlines and cost efficiency. Rating pots are done by managers and director using subjective and objective methods.

The company invests in employee development using for that purpose the following models: traditional, evaluation of the development potential of employees through a standard for comparison, work experience and interpersonal relations.

The most important motivating factor in the company is employee salaries and additional benefits. In addition to wages, the workers are motivated through diverse business trips, team atmosphere and the possibility for personal development. Also, the company cares about the health and safety of employees at work.

The company strictly observes the Employment Contract and the Rules of Procedure, which regulate labor relations. The termination of the contract occurs most frequently because of willing leaving the company, due to the change of residence.

The observed company is very successful and appreciated in the circles of ICT experts. Service users are generally large, financially strong companies. In the workplace of the company there is space only for educated, serious and honest people, with high moral and cultural principles.

References

1. Bolčić Silvano (2003): *Svet rada u transformaciji*, Plato, Beograd, pp. 182-241.
2. Doc. dr Đorđević Boljanović Jelena i prof. dr Pavić Žarko S. (2011): *Osnove menadžmenta ljudskih resursa*, Univerzitet Singidunum, Beograd, pp. 3-205.
3. Doc. dr Kulić Živko (2002): *Upravljanje ljudskim resursima sa organizacionim ponašanjem*, Megatrend univerzitet primenjenih nauka, Beograd, pp. 3-265, 319-375

4. Dr Stefanović Vidoje, dr Cvijanović Drago i dr Vojnović Boško (2013): *Ekonomska efektivnost upravljanja ljudskim resursima*, Institut za ekonomiku poljoprivrede Beograd, Beograd, pp. 9-31, 81-214
5. Đukić Radisav i Jovanović Jelena (2010): *Uvod u menadžment*, Visoka škola tehničkih strukovnih studija, Čačak, pp. 55-98.
6. Menadžment ljudskih resursa, www.edukacija.rs/poslovne-vestine/menadzment/menadzment-ljudskih-resursa (accessed: 13.6.2016.)
7. Mojić Dušan (2010): *Kultura i organizacije*, Čigoja štampa i Institut za sociološka istraživanja Filozofskog fakulteta u Beogradu, Beograd, pp. 45-107.
8. Poslovna dokumentacija analiziranog preduzeća
9. Prof. dr Jovanović Božinov Mića, prof. dr Kulić Živko i prof. dr Cvetkovski Tatjana (2008): *Osnovi upravljanja ljudskim resursim*, Megatrend univerzitet, Beograd, pp. 3-336.
10. Prof. dr Martinović Milan i mr Tanasković Zorica (2014): *Menadžment ljudskih resursa*, Visoka poslovno – tehnička škola strukovnih studija Užice, Užice, pp. 2-158.
11. Prof. dr Petković Mirjana i prof. dr Jovanović Mića (2002): *Organizaciono ponašanje – novi koncept vođenja preduzeća*, Megatrend univerzitet primenjenih nauka, Beograd, pp. 25-111, 209-237, 333-339.
12. Prof. dr Živković Dragić i prof. dr Peševski Mile (2011): *Preduzetništvo u agrobiznisu*, Poljoprivredni fakultet Univerziteta u Beogradu, Beograd – Zemun, pp. 66-68, 143-172.
13. Prof. dr Živković Dragić (2012): *Menadžment ljudskih resursa*, Univerzitet u Beogradu Poljoprivredni fakultet, Beograd – Zemun, pp. 1-226.
14. Upravljanje, rukovođenje, menadžment, www.poslovniforum.hr/management/rjecnik.asp (accessed: 21.6.2016.)

15. Zakon o bezbednosti i zdravlju na radu ("Sl. glasnik RS", br. 101/2005 i 91/2015)
16. Zakon o radu ("Sl.glasnik RS", br.24/2005,61/2005, 54/2009, 32/2013, 75/2014)
17. Zakon o sprečavanju zlostavljanja na radu ("Sl. glasnik RS", br. 36/2010)

THE USE OF THE THEORY OF PLANNED BEHAVIOUR IN THE ANALYSIS OF ENVIRONMENTAL AWARENESS¹

Jelena Karapandžin, Vesna Rodić²

Abstract

Due to its adaptability to different research circumstances, the Theory of Planned Behavior is a useful and commonly used theoretical frame for determining the level of development of an individual's environmental awareness. This paper presents the genesis of this theory, analyzes its individual constructs, explains the way in which these constructs are measured, and provides an overview of the research in which the theory is tested in terms of environmentally responsible behavior of agricultural producers. Finally, this work draws conclusions on the advantages and disadvantages of the application of this theory in analyzing environmental awareness. Although the Theory of Planned Behavior is not a perfect theoretical frame for analyzing environmental awareness, it has certainly been one of the most commonly used theories so far. It is believed that most future analyses of environmental awareness and behavior, environmental decision-making, and application of agro-ecological practices by agricultural producers will rely on this theory.

Keywords: *Theory of Planned Behavior, environmental awareness, agro-ecological practices, agricultural producers*

Introduction

Agricultural production is one of the factors which affect the environmental condition, especially when it comes to exploitation and degradation of natural resources. This is why there is a growing necessity for the development of the so called sustainable agricultural production (Rodić, 2007; Karapandžin and Njegovan, 2015).

¹ The paper is a part of the research on the project III 46006 and OI 179028 which are financed by the Ministry of Science and Technological Development of the Republic of Serbia.

² Jelena Karapanžin, M.Sc., Vesna Rodić, PhD, University of Novi Sad, Faculty of Agriculture, Trg Dositeja Obradovića 8, 21000 Novi Sad; Telephone: +3814853420; e-mail addresses: jelenak@polj.uns.ac.rs; rodicv@polj.uns.ac.rs

The necessity for growth and development of agricultural production is undeniable, given the present and future needs of the mankind. However, pollution and degradation of the environment cannot be the price of this growth and development. Agriculture, due to its biological characteristics (work on and with living beings), as well as to its considerable dependence on ecological factors can have a very positive effect on the environment. However, agricultural practices have had serious negative effects on the environment, such as impairing the quality of land, water, air and living beings (Rodić et al., 2007; Rodić et al., 2011a; Rodić et al., 2011b). This is why there is an urgent need for changes in the current agricultural practices and their adjustment to the sensitivity of the environment, without jeopardizing other demands regarding quality and quantity of food, as well as its availability. These changes must be long-term and stable, as the process of natural resources recovery is slow and demands involvement of all members of society including agricultural producers.

In order to apply sustainable practices and make them accepted in everyday activities of agricultural producers, it is necessary to pay attention both to the factors relevant for the application of current unsustainable practices, as well as the factors which influence the application of sustainable practices. Literature implies the existence of numerous factors which influence the application of more sustainable practices, but it also implies that these factors are conditioned by the context of research, that is, that they differ from case to case (Knowler and Bradshaw, 2007).

In their research, a great number of authors (Welsch, 2011; Lastra-Bravo et al., 2015) point to the fact that one of the factors which significantly influence environmentally responsible behavior is environmental awareness.

Environmental awareness is a very complex phenomenon. Although over 30 years of research and numerous scientific works have been dedicated to this matter, there are no singular, universal and precise methods for its measurement (Karapandžin, 2013).

Most research on environmental awareness and its aspects relies on the Theory of Planned Behavior which was explained and proven by Ajzen in 1991. This theory claims that attitude, subjective norms and perceived behavioral control can predict an individual's intentions and behavior with high accuracy. The Theory of Planned Behavior is, in its essence, based on the assumption that individuals make rational decisions and

choose the options which they see as most beneficial and least costly (Bronfman et al., 2015).

The aim of this paper is to present and explain the Theory of Planned Behavior and analyze its constructs using current research in which this theoretical frame is applied. The Theory of Planned Behavior is analyzed by explaining intentions towards environmental responsible behavior and an individual's behavior, with the emphasis on the possibility of applying this theory in measuring environmental awareness of agricultural producers. The authors explain the genesis of the Theory of Planned Behavior, its individual constructs, and the ways in which they can be measured. Then, they provide an overview of the research in which the Theory of Planned Behavior is tested in terms of environmentally responsible behavior of agricultural producers. In the end, conclusions on the advantages and disadvantages of the application of this theory in analyzing environmental awareness have been drawn.

The Theory of Planned Behavior and its constructs

The Theory of Planned Behavior was developed as an upgraded version of the Theory of Reasoned Action – TRA, created by Ajzen and Fishbein in 1980. The Theory of Reasoned Action originated from the assumption that attitudes and subjective norms represent a precursor of the intention towards certain activities and the implementation of them.

The constructs of the Theory of Reasoned Action are motivational in their nature and imply that if there is an intention towards a certain form of behavior, this behavior will be realized (Ajzen and Madden, 1986). However, as it has become clear that volition towards a certain behavior is not enough to make individuals behave in accordance with their expressed will (especially as some activities require certain demands to be met, such as the possibility for possession and exploitation of certain resources – money, infrastructure, skills, etc.), this theory has been amended.

As the authors state, there are numerous factors that obstruct the control over intended behavior. Those factors can be classified into internal, which include skills, abilities, knowledge and adequate planning, and external, which include time, possibilities, and the fact that an activity's success depends on other people. Many of these factors are in their nature coincidental and cannot be predicted or accurately perceived. This is why a new construct is included in the Theory of Reasoned Action – perceived

behavioral control, as a recognized, subjectively perceived feasibility of a certain activity.

The Theory of Planned Behavior was created with this amendment, and it is based on the assumption that the intentions towards a behavior and the behavior itself are conditioned by the existence of positive attitudes, subjective norms and perceived behavioral control towards a certain behavior (Scheme 1).

Scheme 1. *Theory of Planned Behavior*

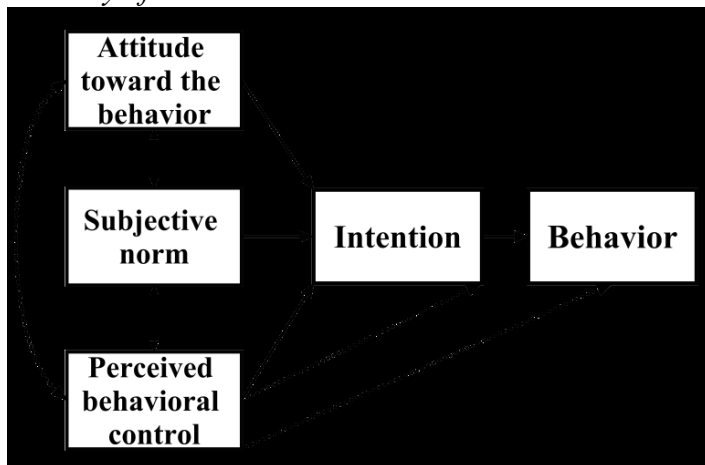

Source: *Ajzen (1991)*

The constructs of the Theory of Planned Behavior are hypothetical, that is, latent variables, which means that they cannot be directly observed and analyzed, but performed. In other words, conclusions about them must be drawn from the perceived answers of the respondents (Ajzen, 2006). It is generally accepted that attitudes, subjective norms and perceived behavioral control are measured using standardized scales for which the respondents give their answers presented as a level of agreement with given statements (Likert Scale). Attention must be paid to the validity and reliability of the scales, which are subjected to statistical tests.

As measuring all constructs of the Theory of Planned Behavior is actually based on self-assessment and self-evaluation of the respondents, insincerity is always a potential problem. Respondents can choose answers which are socially acceptable and/or desirable at the given moment, rather than those which truly reflect their feelings and beliefs. It is certainly easier to express environmentally responsible behavior than apply it in reality. As people

tend to leave a good impression, their responses can be socially acceptable and/or desirable but do not have to be honest (Olli et al., 2001). Ewert and Baker (2001) claim that today individuals are well-aware of environmental issues and are capable of evaluating which answers would be socially acceptable and/or desirable in specific cases. Distortion of answers, that is, enhancing answers (which do not correspond to the actual attitudes) can be a partial explanation for the discrepancy between the expressed environmental attitudes and beliefs and the actual behavior. This will be further discussed in next chapters.

It is practically impossible for the researchers to directly observe behavior of a large number of respondents which would prove environmental awareness of each individual and enable the researchers to make an accurate conclusion on how developed the respondents' environmental awareness is (Thapa, 1999). This is why self-expressed attitudes, subjective norms, and perceived behavioral control are currently the best way of measuring environmental awareness. The mentioned drawbacks simply have to be accepted, as is the case in any research which uses survey methods (Rodić and Kostić, 2011, Kostić and Rodić, 2012). Constant attempts have to be made to lessen, if not entirely eliminate the effect of these drawbacks through sample selection, designing questionnaires, implementation of the so called pilot research, adequate training of surveyors, etc. Of course, while making conclusions one should have in mind that the way in which environmental behavior is measured (real, stated, intended) affects the results of empirical research.

Attitudes

Generally speaking, attitude is an individual's evaluation of some notion and it most commonly represents the expression of how attractive or not attractive the object or subject of observation is. According to Lopez-Mosquera (2016), attitudes are an individual's comprehensive assessment of an object, person or place, and they have a basic influence on the individual's intentions and behavior. According to the Theory of Planned Behavior, attitudes are defined as the level of positive or negative evaluation of a certain form of behavior (Beedell and Rehman, 2000; Wauters et al., 2010).

Environmental attitudes represent one of the elements of environmental awareness, and most instruments for measuring environmental awareness are based on these attitudes. The general assumption is that expressed

attitudes have a strong influence on environmental behavior which is the final aim of environmental awareness.

Measuring environmental awareness by perceiving an individual's attitudes towards environmental issues has been in application since environmental awareness first started being measured, despite certain drawbacks which are constantly pointed at. Namely, it is known that "many attitudes which respondents publicly express are mediated by conformism, which results in socially desirable responses" (Pušić and Pajvančić-Cizelj, 2012). This is especially related to analyzing environmental awareness, as the attitude-behavior relation includes two types of inconsistency (Ajzen and Fishbein 2005, according to Durpoix, 2010). The first inconsistency is literal and it is created when a subject does not act in accordance with what he/she claims (he/she would do). The second is value (estimated) inconsistency and it is created when a general attitude does not correspond to a specific behavior (for example, all animals have the equal right to live, but, as behavior is not in accordance with this statement, certain animal species (for example, snakes, are killed more often than other species).

There are a number of reasons for this discrepancy which appears between environmental attitudes and actual behavior (Rajecki, cit. according to Kollmuss and Agyeman, 2002):

Direct versus indirect experience – Although environmental problems often cannot be limited to a certain area (as the environment is very complex and all processes that occur in it cause reactions which cannot be easily controlled and spatially limited), measuring environmental attitudes, however, has to be adjusted to the circumstances in which individuals live and work. For example, if the citizens of the Republic of Serbia expressed their attitude towards the pollution of oceans, sea world, certain animal and plant species they have never heard of, it is not surprising that their attitudes would not be environmental, that is, that a certain lack of interest, indifference, passivity and/or lack of attitude could be perceived. On the other hand, when analyzing attitudes on environmental issues whose consequences directly affect the respondents (whose consequences can be directly felt, perceived and cannot be ignored by the respondents), it is not surprising that the respondents' environmental attitudes would probably be stronger and also better and more easily assessed. When measuring attitudes it is important to survey those attitudes which are familiar to the

surveyed respondents and for which the respondents have knowledge and information that stimulate reaction.

Social norms, tradition and customs strongly influence pro-ecological or anti-ecological attitudes. There are a large number of examples of traditional and/or religious customs of mass animal sacrifice, although this practice is not environmental acceptable. Moreover, traditional habits in many nations' diet demand consumption of animal products including those of endangered animal species. In such societies pro-ecological attitudes are not in accordance with the accepted social norms and customs and will therefore not be accepted.

Temporal incongruence – While measuring environmental attitudes, special attention needs to be payed to temporal dimension. Namely, people's attitudes and their strength change with time. If attitudes towards nuclear plants are measured immediately after a nuclear catastrophe, the attitudes will be more negative and strongly expressed than if they are measured during a long period of time in which no malfunctions or catastrophes happened (see Prati and Zani, 2012). The passage of time makes people forget, strength of emotions is fading and priority is given to current issues, information and events.

The scope of surveying issues - As Ajzen himself (1991) points out, attitudes should be related to certain forms of behavior, while generalized attitudes towards the environment and ecology should not be analyzed. Concretization of surveying issues and measuring attitudes towards a certain form of activity are the best way of gaining precise and valid answers which help perceive the attitude of the surveyed respondents.

Subjective norms

Subjective norms represent the influence of the people close to an individual (family, friends, colleagues, neighbors, respectable individuals, authorities) on the process of decision-making **Invalid source specified**. More precisely, subjective norms represent an individual's thoughts on how people in his/her surroundings (especially those whose opinion this individual values) see certain forms of behavior, and whether he/she feels pressured to implement or not implement a certain activity. "What would people in my surroundings think if I behave in a certain way?", "Will I be judged or praised?", "What impression will they have of me if I act in a certain way?" – these are the questions which best describe subjective norms.

The point is that some individuals are aware that they will be exposed to prejudice and criticism of those in their surroundings if their activities do not reflect cultural norms or expectations (Burton and Paragahawewa, 2011; Emery and Franks, 2012). This fear can have both negative and positive effects. Whether the effect will be negative or positive depends mostly on the readiness of the community in which the individual lives and works to change behavior (Lastra-Bravo et al., 2015).

Defrancesco et al. (2008) described an important role that thoughts and experience of neighbors play in agricultural producers' decision to adopt or reject agro-ecological practices as one form of environmentally responsible behavior. They emphasize that the influence of the neighboring agricultural producers maintains a strong relationship and cultural norms which are present in many rural areas. Friends, family, neighboring farmers, cattle traders, workers on places where inputs are bought, counselors and authorities are people who influence the intentions towards environmentally responsible behavior among farmers (Borges et al., 2014), which confirms the influence subjective norms have on intentions and, with that, on behavior.

There are many reasons why farmers are under the influence of other people whom they perceive as more important. Martínez-García et al. (2013) state that the reasons can be found in the fact that farmers are actually seeking approval and want to show commitment to the values they wish to share with their families and institutions, or that they are seeking benefits in knowledge and other people's professionalism. If farmers become convinced that other farmers in their surroundings were successful because they applied certain agricultural practices, it is more likely that they will apply those practices themselves (Lamba et al., 2009).

Perceived behavioral control

Perceived behavioral control is determined by the simplicity or complexity of the process of implementing a certain activity in terms of the possibilities an individual has at disposal (Lopez-Mosquera, 2016). Just like attitudes and subjective norms, perceived behavioral control represents an individual's subjective evaluation of the simplicity of implementing a certain activity. What is taken into account are the time and material resources necessary to implement a certain activity and the knowledge and skills which a certain activity demands.

The Theory of Planned Behavior is based on the assumption that if an individual believes that implementation of a certain activity will be difficult, tiresome, complicated, or even impossible, he/she will not have the intention to implement it. On the other hand, if an individual believes that a certain activity can be quickly and easily implemented, that is that he/she has the control over a certain form of behavior, it is more likely that this activity will be implemented. The proof for this claim can be found in the research conducted by Bronfman et al. (2015) who revealed that the respondents mostly implement environmental activities which demand least expense and sacrifice such as saving water and energy, while more demanding forms of environmentally responsible behavior such as recycling, buying organic products, and reduction of car use were rarely implemented.

Perceived behavioral control has a prominent influence on agricultural production. The nature of agricultural production itself implies great dependence on natural conditions on which an individual has relatively little influence (Rodić et al, 2006). In such conditions the producer often feels powerless and is not ready to make additional risks with, for example, different agricultural practices which would be more environmentally acceptable, in fear of even greater uncertainty and risk for production. Convincing people that pro-ecological behavior is easier than usually believed, conducting campaigns which will convince people that pro-ecological activities are achievable, and showing them which activities are the best can result in greater understanding of an individual's behavior and environmental problems (Fujii, 2006).

Perceived behavioral control can be influenced mostly by informing, training and education. Baumgart-Getz et al. (2012), in their meta-analysis of factors that influence the implementation of good agricultural practices among USA farmers, show that the factors which have the greatest influence on the implementation of good agricultural practices are: information accessibility and quality, financial capacity, and connection of farmers with their local extension agency or network.

Although there are different sources of information, it has been shown that the information farmers receive from their colleagues has greater value than that provided by the media, scientific and public institutions (Rogers, 1995 cit. according to Lamba et al., 2009). On one hand, this actually represents the influence of perceived behavioral control (through obtaining information on the specific, environmentally desirable activity).

On the other hand, this represents the influence of subjective norm (through appreciation of certain individuals' opinions).

Agricultural producers often have prejudice towards certain activities, incorrect information or insufficient knowledge about these activities and therefore they believe that it is not acceptable to implement certain practices which would not only have multiple benefits for the environment, but would also have a positive effect on the yield, resource quality and economic result the farmers achieve.

This is why it comes as no surprise that many recommendations are directed towards the improvement of information flow. Schenk et al. (2007), for example, suggest that informing should enable interaction, with a presentation that is easily understood (which means avoiding academic terms and explanations which would sound strange and incomprehensible to farmers, and emphasizing everyday activities they are familiar with). In addition, Wachenheim et al. (2014) emphasize the need for an innovative and efficient method of increasing information accessibility. They suggest social networks and peer education as an effective method of informing farmers. This is the field in which greatest improvements are possible and which would secure the fastest results of institutional efforts.

The application of the Theory of Planned Behavior in analyzing environmental awareness

The Theory of Planned Behavior provides a useful and effective frame for understanding and high-accuracy prediction of specific forms of behavior and agro-ecological practices, as well as differentiating the factors which are influenced by farmers and external factors. This should be taken into account especially in the context of decision-making and creating policies (Wauters et al., 2010). Ajzen, the founder of the Theory of Planned Behavior, leaves a possibility of adding new variables such as socio-demographic variables, moral norms, previous experience and self-identity, with the purpose of providing a better explanation for an individual's intentions and behavior (Lopez-Mosquera, 2016).

In the research related to implementing environmental activities of agricultural producers, Ajzen's Theory of Planned Behavior was applied by, among others, Beedell and Rehman, 2000 and Lalani et al., 2016. Hansson et al. (2012) proved that psychological constructs of the Theory of Planned Behavior affect farmers' decisions related to strategies that will be adopted,

and that the attitudes and subjective norms have considerable influence on the decisions on diversification of farm activities, as well as implementation of environmentally responsible agricultural practices. The research conducted by Wauters et al. (2010) showed that with the increase in the value of all variables of the Theory of Planned Behavior, there is an increase in the rate of adoption of conservational practices.

In their research, Lalani et al. (2016) concluded that the constructs of the Theory of Planned Behavior explain 80% of the variation in intentions towards conservational agricultural practices among the surveyed agricultural producers, while the research conducted by Wauters et al. (2010) explained the variance of behavior with a somewhat lower rate (44-70%). Lopez-Mosquera (2016) applied the Theory of Planned Behavior to test the respondents' readiness to pay for the preservation of a national park. She concludes that the original constructs explain 78% of the intentions to pay, and if moral norms and gender are included apart from original variables, 82% of behavioral variables are explained. A similar research was conducted with the aim to explain variability in the intentions towards implementation of ecological focused area and sustainable management practices (decrease in the use of pesticides, mineral fertilizers, integral agriculture, and use of renewable sources of energy) among wheat producers in Italy. The obtained results show that through standard constructs 55% of variance in the intentions for adoption of these measures is explained, while 81% of these intentions are explained with the expansion of constructs (Menozzi et al., 2015).

Apart from the original Theory of Planned Behavior, which is usually the subject of testing, certain authors have separately tested the influence of attitudes, subjective norms and perceived behavioral control on certain environmental forms of behavior. Their conclusions are different. While some believe that attitudes are the most influential factor for the realized variability in the intentions and environmentally responsible activities (Wauters et al., 2010; Baumgart-Getz et al., 2012), others believe that subjective norms are the ones with the greatest influence (Menozzi et al., 2015; Martinovska Stojcheska et al., 2016), while some believe that perceived behavioral control is the most influential (Price and Leviston, 2014; Lopez-Mosquera, 2016).

Inconsistencies in these authors' conclusions confirm the afore-mentioned thesis that this is a complex phenomenon and that it is very difficult to define all factors which can explain variabilities of environmentally responsible

behavior. However, the fact is that attitudes, subjective norms and perceived behavioral control, as well as key constructs of the Theory of Planned Behavior, can serve as a good starting point **Invalid source specified**. Apart from this, a lot of research conducted so far in which this theory has been applied presents a good basis for spatial and temporal comparisons and perception of changes. Although the Theory of Planned Behavior certainly is not a perfect theoretical frame for the analysis of environmental awareness, it has been the most applied theory so far. All above-mentioned indicates that in the future most research of the environmental awareness, environmental behavior and environmental decision-making will rely on this theory which will undoubtedly continue to develop.

Conclusion

Most measuring of environmental awareness, especially environmental responsible behavior as the purpose and final aim of environmental awareness, is based on Ajzen's Theory of Planned Behavior. This theoretical concept is based on the assumption that human activities are led by beliefs about possible results and evaluation of the results the implementation of those activities will have (behavioral beliefs, which are expressed through positive and negative attitudes), and beliefs about how simple/complex implementation of a certain activity will be.

Having in mind that basic constructs of the Theory of Planned Behavior (attitudes, subjective norms and perceived behavioral control) represent latent variables which are assessed through respondent's answers, there is a danger of dishonest respondents, which is the case with all research based on self-assessment and self-expression. Moreover, so far this theory has not completely succeeded in explaining variability in terms of implementation of certain activities, especially environmentally responsible activities.

With the attitude that 'it is better to measure important facts with less accuracy than less important facts with more accuracy', the authors of this paper strive for the application of the Theory of Planned Behavior while analyzing the achieved level of environmental awareness, with constant efforts to mitigate, if not completely eliminate, the observed drawbacks. On one hand, this can be done with a careful choice of samples, adequate design of questionnaires, conducting the so-called pilot research, adequate training of surveyors and so on. On the other hand, this can be done by adding other constructs and factors which can affect an individual's intentions and behavior, such as socio-demographic factors, moral norms,

locus of control, self-identity, etc. In addition, when using tests in which the Theory of Planned Behavior is implemented, it is necessary to carefully design the scales and direct the research towards a certain form of behavior, because a higher percentage of behavioral variability is explained if testing is aimed at a specific form of behavior.

It is certain that the Theory of Planned Behavior will be applied in analyzing an individual's intentions and behavior in the future, especially in the field of environmental awareness. By observing the process of decision-making and behavior of agricultural producers in their everyday activities in agricultural households, this theory can serve as a valuable theoretical frame which can largely explain the decisions which agricultural producers make or those they will make in the future.

Literature

1. Ajzen, I. (1991) The theory of planned behavior. *Organizational behavior and human decision processes* 50, 179-211. doi:10.1016/0749-5978(91)90020-T
2. Ajzen, I. and Madden, T.J. (1986) Prediction of Goal-Directed Behavior: Attitudes, Intentions, and Perceived Behavioral Control. *Journal of Experimental Social Psychology* 22, 453-474.
3. Ajzen, I. (2006) Constructing a TPB questionnaire: Conceptual and methodological considerations. Available at <http://people.umass.edu/aizen/pdf/tpb.measurement.pdf> (20.09.2016)
4. Baumgart-Getz, A., Stalker, Prokopy, L. and Floress, K. (2012) Why farmers adopt best management practice in the United States: A meta-analysis of the adoption literature. *Journal of Environmental Management* 96, 17-25. doi:10.1016/j.jenvman.2011.10.006
5. Beedell, J. and Rehman, T. (2000) Using social-psychology models to understand farmers' conservation behaviour. *Journal of Rural Studies* 16, 117-127.
6. Borges, J., Lansink, A., Ribeiro, C. and Lutke, V. (2014) Understanding farmers' intention to adopt improved natural grassland using the Theory of planned behavior. *Livestock Science* 169, 163–174. doi: 10.1016/j.livsci.2014.09.014

7. Bronfman, C.N., Cisternas, P.C., López-Vázquez, E., de la Maza, C. and Oyanedel, J. C. (2015) Understanding Attitudes and Pro-Environmental Behaviors in a Chilean Community. *Sustainability* 7, 14133-14152. doi:10.3390/su71014133.
8. Burton, R.J.F. and Paragahawewa, U. H. (2011) Creating culturally sustainable agri-environmental schemes. *Journal of Rural Studies* 27, 95-104. doi:10.1016/j.jrurstud.2010.11.001
9. Defrancesco, E., Gatto, P., Runge, F. and Trestini, S. (2008) Factors Affecting Farmers' Participation in Agri-environmental Measures: A Northern Italian Perspective. *Journal of Agricultural Economics* 59 (1), 114–131. doi:10.1111/j.1477-9552.2007.00134.x
10. Durpoix, D. (2010) Farmers attitudes and behavior towards the natural environment: a New Zealand case study. Ph.D. thesis. Massey University, Palmerston North
11. Emery, S.B. and Franks, J.R. (2012) The potential for collaborative agri-environment schemes in England: Can a well-designed collaborative approach address farmers' concerns with current schemes? *Journal of Rural Studies* 28, 218-231. doi:10.1016/j.jrurstud.2012.02.004
12. Ewert, A. and Baker, D. (2001) Standing for Where You Sit: An Exploratory Analysis of the Relationship between Academic Major and Environment Beliefs. *Environment and behavior* 33 (5), 687-707. doi: 10.1177/00139160121973197
13. Fujii, S. (2006) Environmental concern, attitude toward frugality, and ease of behavior as determinants of pro-environmental behavior intentions. *Journal of Environmental Psychology* 26, 262-268. doi: 10.1016/j.jenvp.2006.09.003
14. Hansson, H., Ferguson, R., and Olof, C. (2012) Psychological Constructs Underlying Farmers' Decisions to Diversify or Specialise their Businesses – An Application of Theory of Planned Behaviour. *Journal of Agricultural Economics* 63 (2), 465–482.
15. Karapandžin, J. (2013) Ekološka svest studenata poljoprivrede. Master rad, Poljoprivredni fakultet Novi Sad

16. Karapandžin, J. and Njegovan, Z. (2015) Agri-environment Measures – Synergy of Agricultural and Environmental Policies: Review. *Thematic proceedings, International Scientific Conference Sustainable Agriculture and Rural Development in Terms of the Republic of Serbia Strategic Goals Realization Within the Danube Region - regional specificities -Belgrade*, December 10-11, 2015, Institute of Agricultural Economics, Belgrade, Serbia, 396-412. ISBN: 978-86-6269-046-3
17. Knowler, D. and Bradshaw, B. (2007) Farmers' adoption of conservation agriculture: A review and synthesis of recent research. *Food Policy* 32, 25–48. doi:10.1016/j.foodpol.2006.01.003
18. Kollmuss, A. and Agyeman, J. (2002) Mind the Gap: why do people act environmentally and what are the barriers to pro-environmental behavior? *Environmental Education Research* 8 (3), 239-260. doi: 10.1080/1350462022014540 1
19. Kostić, S. i Rodić, V. (2012) Metod uslovnog vrednovanja kao sredstvo zaštite životne sredine, *Teme* 36 (2), 663-678.
20. Lalani, B., Dorward, P., Holloway , G. and Wauters, E. (2016). Smallholder farmers' motivations for using Conservation Agriculture and the roles of yield, labour and soil fertility in decision making. *Agricultural Systems* 146, 80–90. doi: 10.1016/j.agsy.2016.04.002
21. Lamba, P., Filson, G., and Adekunle, B. (2009) Factors affecting the adoption of best management practices in southern Ontario. *Environmentalist* 29, 64-77. doi:10.1007/s10669-008-9183-3
22. Lastra-Bravo, X. B., Hubbard C., Garrod G. and Tolón-Becerra A. (2015) What drives farmers' participation in EU agri-environmental schemes?: Results from a qualitative meta-analysis. *Environmental Science & Policy* 54, 1–9. doi: 10.1016/j.envsci.2015.06.002
23. Lopez-Mosquera, N. (2016) Gender differences, theory of planned behavior and willingness to pay. *Journal of Environmental Psychology* 45, 165-175. doi: 10.1016/j.jenvp.2016.01.006

24. Martinez-Garcia, C. G., Dorward, P., and Rehman, T. (2013) Factors influencing adoption of improved grassland management by small-scale dairy farmers in central Mexico and the implications for future research on small holder adoption in developing countries. *Livestock Science* 152, 228–238. doi: 10.1016/j.livsci.2012.10.007
25. Martinovska Stojcheska, A., Kotevska, A., Bogdanov, N. and Nikolić, A. (2016) How do farmers respond to rural development policy challenges? Evidence from Macedonia, Serbia and Bosnia and Herzegovina. 71-83. *Land Use Policy* 59, doi: 10.1016/j.landusepol.2016.08.019
26. Menozzi, D., Fioravanzi, M. and Dona, M. (2015) Farmer's motivation to adopt sustainable agricultural practices. *Bio-based and Applied Economics* 4 (2), 125-147
27. Olli, E., Grendstad, G. and Wollebaek, D. (2001) Correlates of environmental behaviors bringing back social context. *Environment and Behavior* 33 (2), 181-208. doi: 10.1177/0013916501332002
28. Prati, G. and Zani, B. (2012) The Effect of the Fukushima Nuclear Accident on Risk Perception, Antinuclear Behavioral Intentions, Attitude, Trust, Environmental Beliefs, and Values. *Environment and Behavior* XX(X), 1–17. doi: 10.1177/0013916512444286
29. Price, C.J. and Leviston, Z. (2014) Predicting pro-environmental agricultural practices: The social, psychological and contextual influences on land management. *Journal of Rural Studies* 34, 65-78. doi: 10.1016/j.jrurstud.2013.10.001
30. Pušić, Lj. i Pajvančić-Cizelj, A. (2012) Kako građani Vojvodine sagledavaju ekološke probleme: prikaz empirijskog istraživanja. *Sociologija* 54 (1), 153-168. doi: 10.2298/SOC1201153P
31. Rodić, V. (2007) Održivi razvoj poljoprivrede, *Poglavlje u Strategiji razvoja poljoprivrede i sela AP Vojvodine*, Poljoprivredni fakultet Novi Sad i Izvršno veće AP Vojvodine, 137-146
32. Rodić, V., Bošnjak, D. and Vukelić, N. (2007) Sustainability Of Agricultural Land Management, *Thematic proceedings of the 100th Seminar of the European Association of Agricultural Economists:*

Development of Agriculture and Rural Areas in Central and Eastern Europe, 429-439

33. Rodić, V., Zekić, V., Tica, N. and Milić, D. (2011a) Sustainability of Crop Residue Management in Vojvodina, *Proceedings of the 22nd International Symposium „Food Safety Production“*, Trebinje, Bosnia and Herzegovina, 19-25 June 2011, 189-191.
34. Rodić, V., Perić, L., Djukić-Stojčić, M. and Vukelić, N. (2011b) The Environmental Impact of Poultry Production. *Biotechnology in Animal Husbandry* 27(4), 1673-1680. doi: 10.2298/BAH1104673R
35. Rodić, V., Novković, N. i Bošnjak, D. (2006) Organizacija u poljoprivredi, Poljoprivredni fakultet Novi Sad, 1-143.
36. Rodić, V. i Kostić, S. (2011) Problemi ekonomskog vrednovanja životne sredine i prirodnih resursa, *Agroekonomika* 51-52, 39-48.
37. Schenk, A., Hunziker, M. and Kienast, F. (2007) Factors influencing the acceptance of nature conservation measures—A qualitative study in Switzerland. *Journal of Environmental Management* 83, 66–79. doi:10.1016/j.jenvman.2006.01.010
38. Thapa Brijesh (1999) Environmentalism: The Relation of Environmental Attitudes and Environmentally Responsible Behaviors Among Undergraduate Students. *Bulletin of Science, Technology & Society* 19 (5), 426-438. doi: 10.1177/027046769901900512
39. Wachenheim, C., Lesch, W. and Dhingra, N. (2014) The Conservation Reserve Program: A Literature Review. *Agribusiness & Applied Economics Report* 723, 1-22.
40. Wauters E., Biolders C., Poesen J., Govers G. and Mathijs E. (2010) Adoption of soil conservation practices in Belgium: An examination of the theory of planned behaviour in the agri-environmental domain. *Land Use Policy* 27, 86–94. doi: 10.1016/j.landusepol.2009.02.009
41. Welsch, J. (2011) Perception and Attitudes of Landowners towards Re-establishing Native Vegetation on Private Land. Master thesis. Lincoln University, Natural Resources Management and Ecological Engineering.

ORGANIC AGRICULTURE AS A DETERMINANT OF SERBIAN AGRI-FOOD SECTOR DEVELOPMENT

Lela Ristić¹, Vladimir Mičić²

Abstract

In light of the numerous controversies in terms of food quality and safety, organic farming, as a distinctive sector of agricultural production is significantly gaining in importance at a global level. Not only that organic farming is in harmony with the natural processes and principles, it is also sustainable - which is certainly not the case with the conventional agricultural practices and GMO foods production. Despite their numerous benefits, organic products are under-represented in the global market, primarily due to economic reasons. This paper identifies key factors that determine the development of the organic farming sector in Serbia. In this respect, the aim of the paper is to point to the development opportunities of organic agriculture based on the analysis of available resources and by taking into account both internal and external challenges encountered in this particular sector. The fact is that there are significant potentials for development of the organic agri-food sector in the Republic of Serbia, however, these potentials are still insufficiently exploited. Therefore, it is necessary to create a more favorable environment for the future development of this sector.

Key words: *organic agri-food sector, sustainable agriculture and rural development, quality.*

Introduction

At the global level, in addition to producing food in sufficient quantities agri-food sector is also expected to provide quality products, which is a very demanding task in practice. Conventional agriculture allows the use

¹ Lela Ristić, Associate professor, PhD, University of Kragujevac - Faculty of Economics, Djure Pucara Starog № 3, 34000 Kragujevac, Republic of Serbia, Phone: +381 060 33 48 719, E-mail: lristic@kg.ac.rs

² Vladimir Mičić, Associate professor, PhD, University of Kragujevac - Faculty of Economics, Djure Pucara Starog № 3, 34000 Kragujevac, Republic of Serbia, Phone: +381 065 20 10 474, E-mail: miciev@kg.ac.rs

of synthetic substances which, long – termly speaking, pose a significant threat both to human health and the environment. Genetically modified (GM) foods production is one of the major contemporary topics and is the source of many dilemmas and disagreements all around the world. In opposition to the proponents of GMOs, GM food opponents point out to a number of negative environmental, health and economic consequences of both GMOs production and consumption. As numerous doubts and risks concerning food quality and safety are becoming a central topic globally, the new approaches to this field are being developed (integrated and organic farming, functional foods and etc.).

Organic farming differs from other farming systems in many ways. It favors the renewable resources and eco-friendly processes that do not harm the environment, human health or animal health and welfare and bans the use of synthetic compounds and genetic engineering (Schmid et al., 2008). However, despite a number of apparent advantages over the conventional and genetically modified products, organic products are still underrepresented in the international market of agricultural products, primarily for economic reasons. On the other hand, there is an increase in the demand for organic food, as well as other non-food organic products (clothes, shoes, toys, cosmetics, medicines and etc.), especially on those markets whose buyers are aware of the benefits of organic products (contribution to preservation and improvement of human health, improving productivity at work, preserving biodiversity and the environment and supporting economic independence from the large agribusiness systems and etc.).

With a view to global trends in food production and consumption, the current situation in the domestic agri-food sector, as well as the available natural resources favorable for organic production, the subject of research in this paper is the development of organic agriculture as a determinant of the agri-food sector and rural development in Serbia.

The aim of the research is to point to the organic agriculture development opportunities in Serbia based on the analysis of emergence and development of global trends concerning the production and consumption of organic products, as well as the real situation and available resources for organic farming.

In accordance with the defined subject and the aim of the research, the paper builds on the following hypothesis: greater support to the development of the

organic sector improves valorization of agricultural resources, increases production, consumption and export of safe foods of high-quality, particularly in view of the global trends in this sector. Therefore, in addition to the multiplied positive effects on the agro-food system in Serbia, there are also many benefits for the consumers of these products.

For the purpose of the scientific analysis and in accordance with the initial hypothesis and the aim of the paper, several scientific methods relevant for the research in the mentioned scientific field were used. The descriptive method was used in terms of the detailed description of the key determinants relating to the first steps and development of the organic agriculture. SWOT analysis was used to get the better insight into the resource base and the opportunities for the development of the agri-food production in Serbia. Comparative analysis was used in order to compare important indicators relevant for the study. The key indicators used in comparative analysis are based on the data provided by the relevant institutions and supported by the existing scientific and professional literature and applicable laws and regulations. In view of the importance of both theoretical and the empirical approach to the subject matter, the quantitative and the qualitative analyses were used in order to identify the central issues of the organic sector development in Serbia and to point to the strategic steps to be taken in the future.

Given the manifold significance of the production and consumption of organic products, this topic increasingly grows in popularity among producers, consumers and scientists. Namely, many authors (both Serbian and the foreign ones) are giving their attention to the study of the key determinants of the organic sector development (Willer & Lernoud, 2016; Willer & Kilcher, 2012; Paul & Rana, 2012; Marz et al., 2013; Dimitri & Oberholtzer, 2006; Mirecki, 2014; Kalentić et al., 2014; Vujičić et al., 2008; Ristić, 2013; Savić et al., 2012; Mičić and Zeremski, 2011; and etc.). The organic sector is the subject of interest of many international and national organizations and institutions (EC, FiBL, IFOAM, OECD, FAO, UN WCED, Serbia Organica and etc.), as well as the competent ministries in many countries (USDA, FMFA, FOAG, MPZŽS RS and etc.); however, the strategies and approaches of these institutions can greatly differ. It should also be noted that in recent years some of the world's largest agribusiness conglomerates involved in the conventional agricultural production closely monitor the trends in the organic sector and even incorporate some of its principles in their

development, primarily in order to maintain market position and competitive advantage, as well as their profitability and image.

Global organic production and market trends

According to the FiBL research, currently (i.e. in 2016) there are 172 countries worldwide involved in the agricultural production. In 2014 there were about 43.7 million hectares of organic agricultural land, which is quite significant increase compared to 1999 when only 11 million hectares were reported. The countries with the largest increase in the area of their organic agricultural land, though not the largest areas of organic farmland in the world, are: Uruguay, India, Russia, Spain, Italy, France, Indonesia, Sri Lanka, Congo and Canada. However, Oceania has the largest area of the agricultural land that is organic (about 17.3 million hectares) and is closely followed by Europe (about 11.6 million hectares). In terms of individual countries, the countries with the largest areas of organic agricultural land are (Willer & Lernoud, 2016): Australia (17.2 million hectares), Argentina (3.1 million hectares) and the USA (2.2 million hectares), followed by China (1.9 million hectares), Spain (1.7 million hectares), Italy (1.4 million hectares), Uruguay (1.3 million hectares), France (1.1 million hectares), Germany (1 million hectares) and Canada (0.9 million hectares).

The total number of organic producers in the world in 2014 was about 2.3 million (Table 1), which is a significant increase compared to 1999 when there were only about 200 000 organic producers. Today, the largest number of organic producers are in Asia (40%) and Africa (26%), followed by Latin America (17%) and Europe (15%). In terms of individual countries, the country with the most organic producers is India (650,000), followed by Uganda (190,000), Mexico (about 170,000), the Philippines (about 166,000), Tanzania (about 149,000), Ethiopia (about 136,000), Turkey (about 71,000), Peru (65,000), Paraguay (58,000), Italy (about 49,000) and etc.

The countries with the highest shares of organic agricultural land in 2014 (Willer & Lernoud, 2016) were: Falkland Islands (Malvinas) (36.3%), followed by Liechtenstein (30.9%), Austria (19.4%), Sweden (16.4%), Estonia (16.2%), Samoa (14.3%), Switzerland (12.7%), Sao Tome and Principe (12.0%), Latvia (11.2%), Czech Republic (11.1%), Italy (10.8%) and etc.

Table 1. Organic agriculture worldwide

Region	Organic agricultural land (in ha)	Distribution of organic agricultural land by region	Shares of organic in total agricultural land by region	Number of organic producers
Africa	1,263,105	2.9%	0.1%	593,050
Asia	3,567,474	8.2%	0.3%	901,528
Europe	11,625,001	26.6%	2.4%	339,824
Latin America	6,785,796	15.5%	1.1%	387,184
North America	3,082,419	7.1%	0.8%	16,660
Oceania	17,342,416	39.7%	4.1%	22,115
Total	43,666,211	100%	1.0%	2,260,361

Source: based on Willer & Lernoud, 2016.

In terms of the distribution of the main land types and crop categories in the world, the situation is as follows (Willer & Lernoud, 2016): cereals (the key cereal is wheat with the share of about 36%, followed by barley, oats and maize each taking a 10% share, while the largest organic crops areas are in China, the USA, Canada, Italy, Germany and Ukraine); green fodders; oilseeds (key oilseed is soybean and it is followed by sunflower, while the largest organic oilseeds areas are in China, followed by India, Kazakhstan, Sudan and the United States); protein crops; vegetables (the largest producers are the USA, Mexico, Poland, Italy and China); coffee (the largest organic coffee areas are in Mexico); olives (the largest producers are Spain, Italy, Tunisia, Turkey and Greece); grapes (the largest producers are Spain, Italy and France); nuts; citrus fruits (the highest share is that of oranges, while the largest citrus fruits areas are in Italy); cocoa beans (the largest organic cocoa areas are in the Dominican Republic); temperate fruit (the key temperate fruits are apples with the share of 46%, while the largest organic temperate fruits areas are in Poland); tropical and subtropical fruit (the key tropical and subtropical fruits are bananas with the share of 26%, while the largest organic tropical and subtropical fruit areas are in Mexico); legumes (the largest areas are in France and Spain); textile crops (the largest organic cotton producer is India); aromatic and medicinal plants, sugarcane, root crops and etc.

It should be noted that organic products also include some wild species, i.e. wild plants that are collected in nature and are not cultivated by man; therefore, apart from agricultural land there are also other organic areas, such as wild collection areas. Regarding the distribution of all organic areas, agricultural land takes up around 54%, while the share of wild collection areas amounts to 46%. The regions with the largest

concentration of the wild collection areas are Europe (43.5%) and Africa (31.5%), followed by Asia (16.8%), Latin America (8%) and North America (0.2%). However, the largest wild collection areas per country are as follows: Finland, Zambia, India, Namibia, Russia, Romania, Brazil, China, Tajikistan and Bolivia. In terms of the organic beekeeping, Europe has the largest number of hives (70%) and the major European organic honey producers are Bulgaria, Italy, France and Romania. As far as the non-European countries are concerned, the most important organic honey producers are Brazil, Zambia, Ethiopia and Mexico.

Figure 1. *The global market for organic food and drink (billion U.S. dollars)*

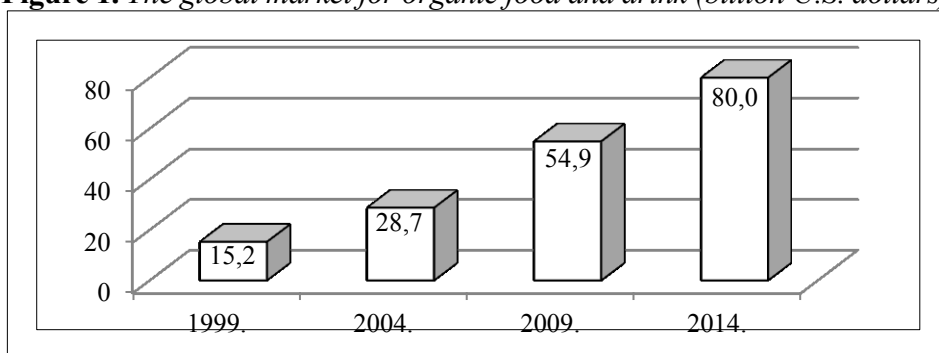

Source: *Organic Monitor, 2016.*

The global market for organic products is continuously growing (Figure 1.). Most organic product sales are realized in North America (47%) and Europe (42%), then in Asia (8%) and Oceania (2%), while all other regions generate only 1% of organic product sales. These figures are confirmed by the findings of the research carried out by the FiBL. In terms of individual countries, the largest market for organic products is that of the USA (43%), followed by German market (13%) and French market (8%) which are significantly smaller compared to the American market. The EU organic market takes up 38% of the global organic product market, while other countries (China, Canada, Great Britain, Italy, Switzerland, Sweden and Austria) have significantly smaller organic markets, however, they are still among the “top-ten” markets for organic products. The sales of organic products in the European market amounted to 11 billion euros in 2004 and in 2014 reached 26 billion, of which the EU member countries (Denmark, Austria, Sweden and Germany) account for nearly 24 billion euros (Willer & Lernoud, 2016). Countries with the highest per-capita consumption of organic products in the world are Switzerland, Luxembourg and Denmark, followed by

Sweden, Liechtenstein, Austria, Germany, the USA, Canada, France, the Netherlands, Norway and Finland.

In Europe, in the period from 1985 to 2014, the organic areas increased from 0.1 to 11.6 million hectares (of which 10.3 million hectares are on the EU territory). Currently in Europe about 2.4% of agricultural land is used for organic farming, while in the EU this share amounts to 5.7%. In terms of particular countries, 30.9% of agricultural land in Liechtenstein is used for organic farming, in Austria 19.4% and Sweden 16.4%. The European organic agricultural land accounts for approximately 27% of global organic farmland. The countries with the largest organic areas in Europe are Spain, Italy and France. The key organic crops grown in Europe are: green fodders, cereals, protein crops, oilseeds, olives, vegetables, fruits and grapes. Based on the data for 2014, of nearly 340,000 organic farmers and growers in Europe, the 260,000 were located on the territory of the EU. The EU countries with the highest number of organic farmers and growers are Italy with 48,662 producers, Spain with 30,602 producers and France with 26,466 organic producers. Turkey also has significant number of organic farmers – 71, 472. Organic processing sector in Europe includes 51,495 processors of organic products, of which 49,968 are located on the territory of the EU mostly in Italy 12,641, France 11,198 and Germany 9,497. Of the 1,847 European importers of organic products, 1,650 are located in the EU (mostly in Germany, Italy and Sweden). Vision and strategy for European organic agriculture builds on the Action Plans passed in 2004 and 2014 (EC, 2004; EC, 2014). The new EU Common Agricultural Policy CAP 2014-2020 also supports organic production. Therefore, the vision of the EU organic agriculture is ambitiously focused on constant improvement (Barabanova et al., 2015).

Development of the organic production in the Republic of Serbia

The abundant natural resources and favorable climate represent solid basis for the development of organic farming and production in the Republic of Serbia. However, the development potential of Serbian agriculture sector has not yet been adequately utilized in terms of production, processing and export of organic products, as well as their inclusion into the tourism offer of Serbia.

Since 2006, following the entry into force of the Law on Organic Production and Organic Products (“Official Gazette RS”, No. 62/06) and the introduction of the incentives for the development of organic

production, there is an increase in the number of producers, organic farming areas, as well as the number of heads/units of certain livestock/poultry species. As far as the regulatory framework is concerned, organic production in the Republic of Serbia is currently regulated by the Law on Organic Production (“Official Gazette RS”, No. 30/10), the Regulation on the Control and Certification in Organic Production and Organic Production Methods (“Official Gazette RS”, Nos. 48/11 and 40/12) and the Regulation on the Use of Incentives for Organic Production (“Official Gazette RS”, Nos. 52/14, 57/14, 71/14, 62/15 and 33/16). Organic production implies such production which is based on the use of organic production methods in all stages of production of agricultural and other products, which excludes the use of genetically modified organisms and ionizing radiation. An organic product is a product cultivated/produced and labeled in accordance with the applicable laws and regulations thereof. The “organic product” label is the sign or logo on the product which indicates that this product can be legally qualified organic and is certified against specific organic standards. The conversion period is the time period required for the transition from conventional to organic production. During this period, a product is referred to as the “product under conversion to organic farming”. The competent ministry delegates control and certification activities related to organic production to certified organizations. The ministry is responsible for the supervision over the mentioned organizations.

Based on the FiBL data, organic farming in Serbia in 2011 was performed on 6,237 hectares, in 2012 there was slight increase in the land area used for organic farming - 6,340 hectares, in 2013 organic production was practiced on 8,228 hectares and in 2014 there were 9,548 hectares of organic farmland. Therefore, we have an increase of 53% in the mentioned period. However, among 172 world countries which reported organic agricultural production, Serbia, in 2014, was on the 89th place considering the size of its organic farmland with its 9,548 hectares. Among 45 European countries that reported organic agricultural production, again, in terms of the size of its organic farmland, Serbia came 33. As for the share of organic areas in the total agricultural land, Serbia, with a share of 0.2% is ranked 107th in the world and 40th in Europe, which further confirms the under-utilization of resources in this sector, particularly bearing in mind the proximity of the EU markets and cooperation with the EU both in the field of the conventional agriculture as well as in other areas. According to the FiBL data for 2013, in addition to a total number of 1,281 organic producers in Serbia (according to the criteria - the number of organic

producers - Serbia was in the 27th place out of 42 European countries) 16 processors, 30 importers and 33 exporters of organic products (Willer & Lernoud, 2016) were registered. The exports of organic products of Serbia in 2013 amounted to around 10 million euros, while the data on the retail sales of these products and their share in total retail sales, as well as per-capita consumption, were not available.

Vojvodina accounts for the largest share of organic plant production (72% of total area is under organic farming), followed by the Southern and Eastern Serbia (16%) regions and the region of Šumadija and Western Serbia (11%). According to the Census of Agriculture 2012, organic crop production including meadows and pastures has the largest share in total organic areas.

In terms of the structure of organic livestock production, poultry, sheep and goats have the biggest share in organic livestock production. This type of production is constantly growing, as well as the interest in organic beekeeping. According to data from 2013, the shares of different types of organic production in total organic production are as follows: cereals 47%, fruit 28%, industrial crops 13%, green fodder 11%, vegetables 2% and aromatic and medicinal plants 2%.

The most common plant species that are grown using methods of organic production are: maize, wheat, soy, plum, apple and raspberry. Organic production in Serbia also includes wild collection - mostly raspberries, strawberries, blackberries, apples, blueberries, mushrooms and etc., which are collected from the wild in accordance with the applicable laws and regulations, however, FiBL is not receiving any official information about wild collection in Serbia, since the country has not yet developed official methodology for the collection of the relevant data.

Domestic market for organic products is underdeveloped as thus far small effort has been made to educate both the producers and the consumers, to promote organic products and the like. Serbia exports organic plant products, mainly primary or semi-processed products. The biggest share in export is that of frozen organic fruits (over 70%). The organic products are mainly exported to Austria and Germany, then the Netherlands and Italy (The Strategy of Agriculture and Rural Development of the Republic of Serbia 2014-2024, 2014).

Opportunities for the development of the organic agri-food sector of the Republic of Serbia and its way forward

Serbia is among the countries where organic production can be successfully developed. In this regard, the SWOT analysis (Table 2) is an important reference base to identify opportunities and possible directions of the further development of the organic sector in Serbia.

Table 2. *SWOT analysis of the development of the organic agri-foods sector in the Republic of Serbia*

Strengths	Weaknesses
<ul style="list-style-type: none"> • Favorable climate • Abundance of land resources • Richness of biodiversity • Geographic location • Vicinity of certain foreign markets • Competitiveness of certain products • Examples of good practice • Growing organic production sector • Improved technology in some processing subsectors • Availability of domestic raw materials • Associations and organizations involved in certain areas of production and processing • Scientific and educational institutions • Openness to implementation of clean technologies • Agri-food sector does not pollute the environment significantly • Serbia is a net exporter of agricultural products 	<ul style="list-style-type: none"> • Underdeveloped infrastructure • Migrations from rural to urban areas • Small-sized farms • Outdated equipment and machinery • Insufficient plant and animal production • Lack of funds • Inefficient quality control system • Insufficient logistical support to the sector • Insufficient implementation of new knowledge and clean technologies • Unsuitable and underdeveloped insurance system • Obsolete, insufficient or insufficiently used capacities of certain processing facilities • Low level of horizontal and vertical integration between producers and processors • Weak bargaining power of producers' associations • Degradation of habitats and biodiversity • Export based on primary products
Opportunities	Threats
<ul style="list-style-type: none"> • More substantial state support for the organic sector • Intensification of integrated and organic production, including the improvement of their promotion and distribution systems • Export of organic products • Harmonization of legislation with the EU standards and regulations, the use of EU funds • Greater interest of investors for the agri-food sector and supporting activities • Quality system improvement • Development of SMEs and entrepreneurship • Production of products with geographical indication, traditional foods, aromatic herbs and spices • Inclusion of organic products in the tourism offer • Alternative energy sources • Cooperation among scientists and professionals at the national and international level 	<ul style="list-style-type: none"> • Inefficiency of resource management system • Lack of funds • Poor cooperation between producers and processors • Growing competition from countries with highly subsidized production • Inadequate response to climate change • Political and economic instability • Decline in living standards and purchasing power • Agro-industry still unprepared for trade liberalization • Poor inspection services • Poor branding of products • Existence of gray economy and monopolies • High costs of new knowledge and knowledge transfer • Insufficient government support • Lack of motivation among producers to accept new knowledge and technologies

Source: *based on the Strategy of Agriculture and Rural Development of the RS 2014-2024, "Official Gazette RS", No. 85/14, pp. 54-56.*

The National Action Plan for Organic Farming Development in the Republic of Serbia gives objective situation of organic farming in the country, identifies the problems in the sector and sets objectives and measures to adequately respond to these issues (Serbia Organica, 2014):

- Objective 1 - refers to the support to the organic farming sector as an integral part of the national agricultural and food policy and the rural development. The measures to be taken in order to achieve this objective are the following: subsidies; inclusion of the representatives of the organic sector in the activities of the relevant working groups; implementation of IPARD programmes and projects in organic farming sector.
- Objective 2 - harmonization of the national legal framework for organic production with the EU legislation. In this regard, the continuous efforts are needed in order to create and establish a comprehensive and efficient system for collecting relevant information, as well as to design a comprehensive database on organic production in accordance with the EU methodology and by taking into account the national interests.
- Objective 3 - refers to institutional development, i.e.: development of the national, regional and local institutions in charge of the organic sector and relevant issues thereof; establishment of a favorable investment environment; providing support to relevant producers' and processors' associations.
- Objective 4 - establishment of an operational and transparent control/inspection and certification system. Measures to be undertaken in this regard are as follows: support to the Accreditation Body of Serbia and the Directorate for National Reference Laboratories; improving the competence of the accredited certification bodies, etc.
- Objective 5 - accessible and demand-oriented advisory services, including: review of the existent advisory services/bodies; hiring knowledgeable professionals and expert consultants; introduction of a more efficient and up-to-date model in terms of advisory services functioning; continuous training of advisors and strengthening their role as educators; knowledge transfer and implementation of the latest scientific research findings into practice.
- Objective 6 - Specified applied research and activities in the field of organic production and processing with clearly defined priorities (agro-biodiversity, genetic resources, plant breeding and genetics, organic seed and planting material, organic plant protection and nutrition methods, organic farming of plants and animals, organic processing technologies) including cooperation between research institutions and the key actors in practice, introduction of clean technologies and more efficient international cooperation.

- Objective 7 - the development of the organic sector through inclusion in the formal and informal education curricula. In this regard, following measures are to be implemented: improving education curricula, improving teaching skills and specific knowledge of educators; provision of up-to-date literature; better cooperation between domestic and foreign universities; development and promotion of lifelong learning programmes, etc.
- Objective 8 - development of the domestic market for organic products by implementing the following measures: continuous analysis of the situation on the national market for organic products; establishment of well-stocked and organized retail outlets (markets and shops), as well as online shops; cooperation with the retail chains that sell organic products; educational and promotional campaigns to improve perception of Serbian consumers on organic produce.
- Objective 9 - growth in exports of organic products; this requires: monitoring the needs and behavior of consumers in international markets, as well as global trends and prices; trainings in the field of marketing for the economic operators who plan to establish themselves in international markets; more active role of the state in the promotion of exports; support to domestic producers and processors to participate in international trade fairs (BIOFACH, etc.).
- Objective 10 - creating more favorable conditions for the production and processing of organic products. Measures to be taken in this respect are the following: subsidies; drawing up the list of registered organic inputs with detailed information on their availability; providing training and education programmes to manufacturers; development of an Info Center and/or help desk services etc.
- Objective 11 - implementation and monitoring of the achievement of the objectives and measures laid out in the organic sector development plans and programmes. Measures to be implemented thereof are: development of a detailed plan of activities to support organic sector with clearly defined stages and deadlines for their achievement and adequate budget planning; establishment of the bodies responsible for monitoring the implementation of such objectives, setting out the adequate methodology and guidelines for monitoring, control and audit activities.

By providing the adequate support to the development of Serbian organic agri-food sector, the necessary conditions for its long-term development will be also created. However, in order to support the development of this sector, in addition to the National Action Plan, an official strategy is

required, as well as other means of state support, including more active role of local governments, substantial budgets, private initiatives, programmes and projects in this area.

Conclusion

Due to the excessive and uncontrolled, i.e., improper use of synthetic substances and chemicals in conventional agri-food production, as well as the rise of numerous controversies and dilemmas in terms of GMO products, the new approaches to food quality and safety are being developed that greatly differ from the conventional ones. In addition to the commonly applied quality standards (ISO, IFS, HACCP, HALAL, Kosher, GLOBAL G.A.P., BRC, CE, GOST-R, Demeter, etc.), the concept of organic production itself is being developed. Ecological principles, good health principles, the principle of fairness, the principle of nurture and care, are all contained in this concept so as to preserve the soil, water and air quality, the human, plant and animal health and welfare, as well as aid the survival of humans and other life on the planet. This concept insists that natural processes are to be followed and resources managed in such a manner so as to protect the health of present and future generations. Organic production is in line with the principles of sustainable development, that is, environmentally and socially acceptable, and from the economic point of view it can be assessed positively. Furthermore, in institutional terms, it is beneficial to both the economy and the society, especially in the long term period.

Natural and anthropogenic factors, particularly strategic goals and legislation, as well as the available funding sources (which all differ from country to country), significantly determine the direction and the level of the organic sector development. This is confirmed by theory and empirical evidence worldwide. It has been observed that greater commitment to the development of the organic market brings multiple benefits, however, at the same time it requires the fulfillment of certain preconditions, both on the supply and the demand side. In this respect, it has been perceived that in the “developed world” demand for organic products is constantly increasing, while the less developed countries with rich resource potential for this type of production are working on improving the competitiveness of their exports.

The development of rural areas and agriculture is very important for Serbia, especially bearing in mind the available natural resources, farming

tradition and quality local foods. However, despite the obvious importance of the agri-food sector and the rural development, the national policy and strategic documents still do not offer adequate solutions for the more efficient utilization of the agricultural resource potential concerning both conventional and organic production.

Official statistics, relevant reports, development indicators, scientific and technical analyses and numerous case studies, suggest that it is necessary to pay more attention to the development of the organic sector in the upcoming period, because this sector has manifold significance not only for farmers, processors and consumers, but also for the state itself. The role of the state is crucial in creating a favorable environment for the development of the organic sector.

The initial hypothesis set out in this paper is thus confirmed. It is evident that the more substantial institutional support to the organic sector development can really significantly improve valorization of agricultural resources, boost production, consumption and export of high-quality safe foods, i.e., provide different and numerous benefits.

The key limitation regarding the subject of this paper refers to the lack of long-term and comprehensive official statistics in the country regarding the mentioned subject matter, although the documents the National Strategy for Agriculture and Rural Development 2014- 2024, the Census of Agriculture 2012 and Chamber of Commerce and Industry of Serbia, provide information on certain indicators in this area. However, the lack of precise data on retail sales and consumption of organic products in the Serbian market is evident. Another problem is the inexistence of a national strategy that would solely focus on the development of the organic agriculture.

Available indicators and findings of numerous analyzes in the field of organic production point to the fact that, given the current food quality and safety issues, as well as other relevant factors, Serbia has excellent opportunities for the development of the organic sector. Therefore, it is expected that this study, including the previous research in this area and the examples of good practice in the country and abroad, contribute to the further development of the organic sector in Serbia and help achieve numerous strategic goals related to the Danube Initiative, the EU integration process, the WTO membership and etc.

The state support programmes for the export-oriented organic producers, efforts of local governments to support agricultural and rural development, various private initiatives to increase investment activity, as well as projects of national and international organizations related to this sector, along with other related activities, could greatly contribute to improving the competitiveness and the image of Serbian organic produce. It is very important to always have in mind the national interests, with particular emphasis on the survival and development of small farms currently engaged or about to-be-engaged in the organic farming.

Literature

1. Barabanova, Y., Zanolli, R., Schluter, M., Stopes, C. (2015): *Transforming food & farming: an organic vision for Europe in 2030*, IFOAM EU Group, Brussels.
2. Vujičić, M., Jovanović, P., Ristić, L. (2008): *Turizam i agrobiznis*, Državni Univerzitet u Novom Pazaru, Novi Pazar.
3. Dimitri, C., Oberholtzer, L. (2006): *EU and U.S. Organic Markets Face Strong Demand Under Different Policies*, USDA-ERS, USA.
4. EC (2004): *2004 European Action Plan*, EU, Brussels.
5. EC (2014): *Action Plan for the future of Organic Production in the European Union*, European Commission - EU, Brussels.
6. *Zakon o organskoj proizvodnji i organskim proizvodima*, „Službeni glasnik RS“, br. 62/06.
7. *Zakon o organskoj proizvodnji*, „Službeni glasnik RS“, br.30/10.
8. IFOAM, *International Federation of Organic Agriculture Movements - Organics International*, Bonn, Germany, <http://www.ifoam.bio/en> (sajt posećen 04.10.2016.)
9. Kalentić, M., Stefanović, E., Simić, I., Marz, U. (2014): *Organska poljoprivreda u Srbiji 2014*, Serbia organica - Nacionalno udruženje za razvoj organske proizvodnje, Beograd.

10. Marz, U., Kalentić, M., Stefanović, E., Simić, I. (2013): *Organska poljoprivreda u Srbiji 2013*, Serbia organica - Nacionalno udruženje za razvoj organske proizvodnje, Beograd.
11. Mirecki, N., (2014): *Organska proizvodnja*, Biotehnički fakultet, Podgorica.
12. Mičić, V., Zeremski, A., (2011): *Deindustrijalizacija i reindustrijalizacija privrede Srbije*, Industrija, 39(2), str. 51-68.
13. MPZŽS RS, *Ministarstvo poljoprivrede i zaštite životne sredine RS*, <http://www.mpzzs.gov.rs/> (sajt posećen 04.10.2016.)
14. OECD (2003): *Organic agriculture: sustainability, markets and policy*, Workshop on Organic Agriculture, CABI, Wallingford.
15. *Organic Monitor*, London, UK, <http://www.organicmonitor.com/> (sajt posećen 04.10.2016.)
16. Paul, J., Rana, J. (2012): *Consumer behavior and purchase intention for organic food*, Journal of Consumer Marketing, 29(6), pp. 412–422.
17. *Pravilnik o kontroli i sertifikaciji u organskoj proizvodnji i metodama organske proizvodnje*, „Službeni glasnik RS“, br. 48/11 i 40/12.
18. *Pravilnik o korišćenju podsticaja za organsku proizvodnju*, „Službeni glasnik RS“, br. 52/14, 57/14, 71/14, 62/15 i 33/16.
19. Republički zavod za statistiku, *Popis poljoprivrede 2012*, <http://popispoljoprivrede.stat.rs/> (sajt posećen 05.10.2016.)
20. Ristić, L. (2013): *Strategijsko upravljanje održivim ruralnim razvojem u Republici Srbiji*, Ekonomski horizonti, Ekonomski fakultet Univerziteta u Kragujevcu, 15(3), str. 229-243.
21. Savić, LJ. Bošković, G. Mičić, V. (2012): *Assumptions and possibilities of the development of the Serbian food industry*, Ekonomika poljoprivrede, Institut za ekonomiku poljoprivrede, Beograd, 59(4), str. 753-767.

22. Serbia Organica (2014): *Nacionalni akcioni plan za razvoj organske proizvodnje za period 2014-2019. godine - radna verzija*, Nacionalno udruženje za razvoj organske proizvodnje, Beograd.
23. *Strategija poljoprivrede i ruralnog razvoja Republike Srbije za period 2014-2024*, „Službeni glasnik RS“, br. 85/14.
24. Schmid, O., Dabbert, S., Eichert, C., Gonzálvez, V., Lampkin, N., Michelsen, J., Slabe, A., Stokkers, R., Stolze, M., Stopes, C., Wollmuthová, P., Vairo, D., Zanolì, R. (2008): *Organic Action Plans*, FiBL, Switzerland & IFOAM-EU Group, Belgium.
25. UN WCED (1987): *Our Common Future – Report*, World Commission on Environment and Development, UN.
26. USDA, *Organic Agriculture*, United States Department of Agriculture, Washington D.C., United States of America, <http://www.usda.gov/wps/portal/usda/usdahome?navid=organic-agriculture> (sajt posećen 01.10.2016.)
27. FAO (2007): *SARD and organic agriculture*, Food and Agriculture Organization of the United Nations, Rome, Italy.
28. FiBL, *Research Institute of Organic Agriculture*, Frick, Switzerland, <http://www.fibl.org/en/about-us.html> (sajt posećen 01.10.2016.)
29. FMFA, *Federal Ministry of Food and Agriculture*, Bonn & Berlin, Germany, http://www.bmel.de/EN/Homepage/homepage_node.html (sajt posećen 04.10.2016.)
30. FOAG, *Organic farming*, Federal Office for Agriculture, Bern, Switzerland, <https://www.blw.admin.ch/blw/en/home.html> (sajt posećen 04.10.2016.)
31. Willer, H., Kilcher, L., (2012): *The World of Organic Agriculture - Statistics and Emerging Trends 2012*, FiBL, Frick & IFOAM, Bonn.
32. Willer, H., Lernoud, J. (2016): *The World of Organic Agriculture. Statistics and Emerging Trends 2016*, FiBL, Switzerland & IFOAM, Germany.

THE POSSIBILITY OF ASSOCIATION OF WATER USERS IN IRRIGATION IN AGRICULTURE¹

Ljiljana Rajnović², Biljana Grujić³

Abstract

There is no doubt that agriculture is an important factor of economic activity in the Republic of Serbia, taking into account the size and the quality of agricultural land. Therefore, the need for irrigation of agricultural land should be given appropriate significance, considering the uneven distribution of precipitation during the agricultural season, as well as the continuous climate changes in the country and in the region. Republic of Serbia is characterized by fragmentation of agricultural properties, a large number of land parcels with relatively small areas, that complicates and requires higher costs of irrigation of the plots and the construction of irrigation systems. A large number of plot holders (owners and users) of relatively small areas, usually do not have enough necessary financial resources nor has sufficient credit capacity to independently build an adequate irrigation system and thus contribute to a better yield in agricultural production, for themselves and on the state level. Financing of irrigation in crop production is insufficient to motivate agricultural producers to become seriously engaged in this activity. Considering all aforementioned, it is obvious that there is a need for normative and practical editing issues of irrigation in agriculture, organized by specific organizations, established by the owners or users of agricultural land, for the sole purpose of meeting the needs for irrigation of land in order to control the quality of production and the provision of better yields.

Keywords: *agriculture, public welfare, water users, water users association, irrigation system, lending irrigation.*

¹ The work is part of research project no. 46006: "Sustainable agriculture and rural development in terms of achieving the goals of the Republic of Serbia within the Danube region", funded by the Ministry of Education, Science and Technological Development of Republic of Serbia.

² Ljiljana Rajnović, PhD, Research Associate, Institute of Agricultural Economics, Volgina 15, 11060 Belgrade, tel. +381 63 273 237, e-mail: ljrajnovic@yahoo.co.uk.

³ Ma Biljana Grujić, Research Associate, Institute of Agricultural Economics, Volgina 15, 11060 Belgrade, tel. +381 11 69 72 842, e-mail: biljana_g@iep.bg.ac.rs.

Introduction

Considering the fact that agriculture is an important industry in the Republic of Serbia, and that to the agriculture, as to a branch of activity, is given priority in the strategic plans of the Republic of Serbia, thus the need for irrigation of agricultural land penetrates to the fore, considering the above-mentioned reasons. Lack of water in the vegetation period causes fall of agricultural production, which all reflects in the overall economic balance of the Republic of Serbia.

Because of the fragmented agricultural lands, and lack of necessary financial resources, area under irrigation in Serbia is still very small compared to other countries. Data from official records of the Republic of Serbia about the irrigated areas are incomplete and according to some estimates, it is officially recorded only a tenth part of the area under irrigation.

Situation in irrigation in Serbia

For the Republic of Serbia, as well as for all countries in which social and state capital was prevalent, it is characteristic that in the past period, activities of irrigation and construction of irrigation systems, were performed mainly by social and state companies, that cultivated as owners of their own properties, or users of state land, large areas of agricultural land.

After the ownership change of the social capital, or state capital in previous companies, and after the formation of new economic societies, this kind of a production structure in agriculture has been significantly changed, and the accent is now on agricultural producers, entrepreneurs or companies which are engaged in agricultural production, that results in devastation of previously constructed system, as well as in reducing the areas that once were covered by the irrigation system.

Construction of irrigation systems involves obtaining the proper licenses, in accordance with the regulations on construction, as well as the water acts issued by the ministry of agriculture and water management, or water administration in the Netherlands⁴, that all require the expenditure of significant resources, time and knowledge. From the standpoint of the owner or user of agricultural land which cultivates relatively small

⁴ Preliminary provisions of the Act of June 6.1991. which refers to water administration.

property, this often represents a significant barrier, and as a result of this, it is usual to meet in practice with an inadequate irrigation:

- the use of tap water,
- groundwater or surface waters without the necessary permits.

As the final result of this, it comes to irrational use of water as a good of general interest, environmental damage and other negative consequences, which includes the inability of the state to introduce these users into the system of paying compensation for use of water.

The standard solutions, legislative solutions and forms of association in the field of irrigation in the European Union and the possibility of the Republic of Serbia

In the whole world, the power of management and usage of water is closely related to environmental protection. The most important international legal framework of environmental protection make the UN Conference on the Humanitarian Environment held in Stockholm in 1972, the adoption of the report of Brutland commission by the UN in 1983. year, and the UN Conference on Environment and Development held in 1992 in Rio de Janeiro. Period of developing of international legal framework in the area of management and the usage of water takes about 40 years, because all the regulations governing the protection of the environment, are more or less directly related to management and use of water.

In accordance with these international regulations, in almost all countries of the European Union, with special normative acts is regulated the matter that provides the possibility and terms of irrigation in agriculture⁵, for which called. Common Agricultural Policy (Common Agriculture Policy - CAP) is allocated about 50% of the annual budget of the European Union and the agro food sector is generally of the utmost importance for the European Union.

The main objective of the adoption of specific regulations that governing the possibility of association of water users is to create conditions for the development of irrigation and the development of private initiative in the construction of the irrigation system in a way that ensures the preservation of water and provides integrated water management and

⁵ Water user associations act of Bulgaria.

meet the needs of agriculture for water, with respect of restrictions imposed by the preservation of balance in nature.

Laws, placed on such principles, respect international practice and trends in the field of irrigation, agricultural production and water management⁶. These laws can also create conditions for the further involvement of private agricultural producers in the field of irrigation, as well as conditions for the development of democratic decision-making among water users, and provide evidence of the irrigation system that is built up in the organization of the association, in accordance with these laws. In this way it contributes to development of agriculture and irrigation, introduces a better evaluation of water resources and *property* and gives more importance to modern agriculture. Applying the principle "user pays" , which means that anyone who uses water resources, water facilities and water system, as a well of general interest, is obliged to pay for its use the real price, through the provision of resources by all users of water resources, and in this way, material conditions for the realization of the basic goal of the law are created, and which goal is- controlled use of water for irrigation.

The laws that in specific way regulate the possibility of association of water users also regulate the subject of regulation: establishment, entry in the register and the status of water users associations, membership, bodies and property of the association, the termination of the association, as well as other issues relevant to the work of the association with an aim of respecting the interests of all water users, as well as goods of general interest.

Almost all rules governing the legitimacy of founders in a unique way, so that the founders of an association⁷ may be **all business capable natural persons** and legal entities under the condition that they are owners or users of agricultural land⁸, but only in the boundaries of irrigation area for which the association is established. In this way, associations are defined as territorial organizations, with clearly defined irrigation area, or an area that would be irrigated with the system owned by the association. Territorial determination prevents membership of association of accessing persons with a purely speculative reasons, in order to allow that the

⁶ *Water Users Association in productivity in Northern China*, Lei Zhang, Nico Heering, Liesbeth Dries, Xiaoping Shi

⁷ How to establish a Water Users Association, IWMI International Water Management Institute; SICWC Scientific Information Center, Interstate Commission for water coordination.

⁸ Article 2. Water user associations act of Bulgaria, Draft Law of the Republic of Serbia on associations of water users in agriculture.

members of the association can only be people who have a genuine interest and the need for irrigation of agricultural land which they use.

Also, the regulations generally governing the minimum number of founding members. There is a widespread standpoint that minimum 3 founders are sufficient to form an association. This solution is prescribed by the current Law on associations of the Republic of Serbia, considering the fact that there is no specific legislation that regulates the possibility of joining of water users in agriculture, although the Republic of Serbia launched a legislative process in order to integrate similar law rules in its positive legislation. This law is prepared by the competent ministries, and it also underwent the procedure of public debate, but it still hasn't been adopted by the legislature.

It is obvious that the solution that provides mentioned minimum of founders of association, is liberal enough to allow all interested parties to create an association. Due to differences in the size of the estate and cultures that are grown on the property, we believe that we should not restrict too much the establishment of associations with prescribing a larger number of needed founders.

The regulatory framework of the Republic of Serbia and justification for the adoption of legislation on water users association

There are no regulations that in a comprehensive manner, and as the primary substance, regulate irrigation, nor private initiative of interested persons in this area, in Republic of Serbia. The aforementioned draft Law on associations of water users in irrigation in agriculture⁹, analog to the generally accepted rules of the European Union, defines the content of the draft law, addressing the necessary issues of the establishment, entry in the register and the status of water users associations, membership, authorities and property associations, termination associations, inspection supervision of associations of water users, so achieving of the desired goals, and effects that these laws have in the European countries is not possible without the adoption of a special law.

While it was preparing the draft law, Ministry responsible for agriculture and water management, as a promoter, used a number of scientific research and other professional knowledge and expertise of professionals

⁹ Draft Law of the Republic of Serbia on associations of water users in agriculture.

in the field of irrigation, within the domestic and foreign theories and practices. Extra attention is given to the domestic legislation and legal resources of foreign countries, which integrated similar legislation in its positive legislature. In addition, the literature of the World Bank was also used, and the bank also helped the development of irrigation in the Republic of Serbia and other countries through the finance, but the law has not been adopted, although the constitutional basis for the adoption of this law is contained in the Constitution of the Republic of Serbia which guarantees the freedom of association.

In accordance with the Constitution of the Republic of Serbia¹⁰, with the aforementioned law should be legislatively regulated issues of irrigation in the organization of specific associations, established by the owner or user of agricultural land for the sole purpose of meeting the needs of irrigation land, modeled on the regulations of the European Union.

Proposed solutions include that the water users associations are established only by persons who have a real interest in the construction of irrigation systems, or persons to whom the exploitation of systems will bring revenue, or additional income. The proposed draft law provides that the establishment and further financing of the association will take place solely through private initiative, while the administration and operation of the association will be informal and it would not require significant costs.

The idea was to create opportunities for associations to join together in alliances, as well as in the international associations of similar type. Freedom of association is guaranteed by the Constitution, and this provision represents a further concretization of the rights under the Constitution.

Analysis of the positive effects of association of water users

Solutions proposed in the regulations that specifically regulate the possibility of associations of water users undoubtedly have beneficial effects on agricultural producers, namely:

- **natural persons**, individual farmers who are owners or users of agricultural land,
- legal entities that realizing their activities in agriculture, and which are the owners or users of agricultural land
- State in the sociological sense.

¹⁰ Article 55. the Constitution of the Republic of Serbia.

The proposed solutions in the draft law allow mentioned persons the establishment of water users' associations only if they are owners or users of agricultural land, so it is possible to assume that the direct effects of the adoption of the law in a positive sense would feel primarily those persons.

Positive effects of the solution referred to the draft law would be manifested through improving irrigation, improving agricultural production and thereby increasing revenue, or standard of aforementioned persons, and as an indirect positive effects, though no less important, is an increase in the value of agricultural land covered by irrigation systems built on the initiative of the association which founding is enabled by this statute, the growth of standards and employment in agriculture, economic development leaning on agricultural production due to providing a safer raw material base, more secure agricultural production due to the lack of a result of drought, as well as safer prediction of price movements of agricultural crops that are irrigated, all of which reduces the pressure on inflation, in which formation prices of agricultural crops have a significant contribution.

Water Users Associations are, by proposed solutions from the new statut, defined as non-profit organizations that do not carry out activities on the market in order to make profit. Associations are funded by members and they provide their services to their members, so to the narrow range of users, not to all interested parties in the market. Also, considering the territorial nature of water users associations, their mutual competition in market is excluded.

Membership in the association of water users

In parallel legal jurisdictions is prevailing the view that a member of association can be any **business capable natural person**, entrepreneur or legal entity who is the owner or user of agricultural land¹¹ within the limits of the irrigation area. It is believed that the owner has the priority right to membership in relation to the users of the same agricultural land, so the membership in the association on the basis of one, or the same parcel, may realize the owner or user. In cases where it comes to the user, he has to have regulated property and legal relations with the owner of the land and approval, given in no uncertain terms from the owner, in order to become a founder or member of the association.

¹¹ Article 21. Water user associations act of Bulgaria.

All members are equal, obliged to adhere to the established objectives, principles and activities of the association, acts of associations, and to participate actively in the work of the association.

The point is that there is a unique irrigation system used in the way so that each member is in an equal position while using water, considering the size of the land, characteristics and culture that is grown, and available water is used rationally and economically, so as not to jeopardize the objectives of environmental protection, or the state in the sociological sense.

It is common that any interested person, as a new member of the association can access later, but if the specifications of a unified irrigation system allow that. Some countries allow the accession of new members who have the right of ownership or who use the land on which is the system of irrigation, with fulfillment of other requirements of the law and act of Water Users Association. In order to access the association, the interested person submits a request, which contains information about the person concerned, as well as data on agricultural land, and if it is about user of land, it must contain the proof that he arranged legal rights with the owner, and the owner's consent also. The decision about admission a new member usually make the competent authority, and it in general enters into force only when the new member of association pay proportionate share of the costs of construction, rehabilitation, or reconstruction of a unified system of irrigation on the subject irrigation **surface**. From the date of entry into force of the decision, a new member shall also bear costs of maintaining of a unified system for irrigation, and other costs in accordance with the law and acts of the Association, as well as other members.

Acts of associations mainly prescribes the duty of payment of membership fees by members within specified time limits, and the way of paying costs relating to the irrigation system. Thus is usually stipulated that construction costs, maintenance costs, renovation or reconstruction, as well as the operating costs of a single system irrigation are bored by all members of the association, in proportion to the size of their agricultural land within the irrigation area, in relation to the irrigation area. It is usually prescribed the sanction for a member who did not pay the costs of maintenance, rehabilitation or reconstruction, as well as the operating costs of a single irrigation system within a limit set by law, so they will not be taken into account while making a plan of water consumption and will not be allowed to use water irrigation as a member of the association for the current year.

In that way it is generally provided that a member is obliged to pay compensation for use of water for irrigation, usually in proportion to the size of its agricultural land, and if the association has the technical requirements for measuring the amount of water consumed, then the fees may be charged on the basis of actually consumed water.

Assets of Water Users Association

Water Users Association, as legal entity, has their own property which is used for performing the activity. The Association may acquire assets from membership fees, voluntary contributions, donations and gifts, subsidies, legacies, interest on deposits, rent and on the other legally permitted manner, and in order to achieve the statutory goals of the association¹². For its obligations, the association corresponds to the whole property. Asset of association, considering unprofitable character of association, can't be shared to members, nor to employees, and in the case of termination of the association, belonging of the property is regulated in various ways, starting with the fact that the property becomes joint property of association members, or it belongs to the property of another association in that territory¹³.

In a situation where it is necessary for the construction, rehabilitation or reconstruction of a single irrigation system, the association may request **the right of way over someone** else's property, or the right to use someone else's property. Association and the owner or holder of the right of disposal, or the right of use of immovable property, conclude a contract which shall specify the manner of performing easement, or the right of easement shall be established in accordance with the relevant law that regulates the mentioned area.

In addition, the rules define activities undertaken by the association. All activities are subordinated and they arise from the objectives of association. Of course, considering the overriding character of private associations, the activities of the association are given as an open list, and members of the association may decide to perform other activities related to the objectives of association. Also, in some legislation it is provided that an association may perform an economic activity for earning profit which solution is adopted in the current Law on Associations, which

¹² Article 46. Water user associations act of Bulgaria.

¹³ The Law on Associations of the Republic of Serbia.

stipulates that conditions for carrying out economic activities are the same as those prescribed for all other associations.

The question of editing rules related to adoption of annual work program for planning activities of the association for the year concerned is mainly left to acts of the association¹⁴, so that, among other things, in this way are determined the resources for implementation of the annual plan of the association.

The objectives achieved by pooling water users¹⁵

The EU countries regulations, that specifically regulate the association of water users for irrigation of agricultural land on which they have possession, which include conspiracy to irrigation development is mainly based on the following basic concepts:

- **Freedom** of association of water users, which is guaranteed by the Constitution, with the obligation to register all forms of association, in accordance with the regulations of the countries in which they perform activities
- Meet the needs of water users in the area of irrigated farmland and participation in the use of water as a natural resource, while respecting the interests of the state in the preservation of water resources;
realizing the interests of the association members and the interests of the state in the irrigation of agricultural land;
- realization of democratic decision-making through the participation of all members of the association in the establishment and operation of associations of water users, either directly or through elected bodies of the association;
- making decisions related to the operation of associations of users, taking into account primarily the size of the possessions of all the members of the association of water users and mainly on that basis, the acquisition of rights and obligations;
- ensuring the rational use of water, as well as the consecutive distribution to the customers;
- Protection of land from erosion, salinity and excessive humidity;

¹⁴ How to establish a Water Users Association, IWMI International Water Management Institute; SICWC Scientific Information Center, Interstate Commission for water coordination

¹⁵ Water Users Association for Sustainable Water Management, World Conference of Science contribution from International Hydrological Programme of UNESCO

- rational use and the use of available water resources, taking into account the interests of all users, while in most number of countries the water supply of the population and maintaining the ecosystem has a priority;
- Environmental Protection;
- Irrigation has an economic value that is significantly reflected in agricultural production;
- regulations that in specific way regulate the association of water users in irrigation does not prevent nor restrict the individual and other initiatives in the field of irrigation.
- Pooling water users on the basis of special regulations that governing the mentioned matter are provided by:
 - continuous and stable financing of the association of water users,
 - paying the price of water and services related to irrigation on the principle of "user pays" by end-users,
 - in addition, the state can have an incentive to finance the construction of water facilities and irrigation systems, ensuring balanced regional and agricultural development.

Principles of association of water users

Regulations that governing irrigation by water users, govern the basic principles that the association should respect while undertaking the activities of the association. The application of these principles should ensure equality of members of the association, democratic decision-making of members, informing members, equitable allocation of available water, the implementation of good agricultural practice, participation in integrated management of water, and in relation to that, provision of the environment protection.

Most prescribed principles which should be adhered by water users association, associating owner, or user of agricultural land is based on the following principles:

- The principle of voluntariness - accession of members to the associations of water users, as well as the resignation from the association is based solely and exclusively on the decision of the interested persons;
- The principle of freedom of association - it is recommended the rule that to the associations of water users can access all natural persons,

entrepreneurs and legal entities interested in using the water irrigating their plots;

- principle of integrated water management - water users association are the subjects that participate in decision-making related to the use of available water resources together with other companies including the state in order to meet their own and the public interest;
- The principle of non-profit operation - water users association are established as non-profit organizations where the primary aim is not to carry out economic activities in order to acquire and distribute profits, but the satisfaction of its need for irrigation;
- The principle of legal personality - water users association are designed to operate as legal persons, business entities that in legal transaction act independently in the name and on behalf of associations and for its obligations corresponding to its property;
- the principle of respect of objectives of association - water users association was founded to achieve the objectives laid down by law, so in that sense, all activities of the association must be subordinated to the achievement of stated objectives;
- the principle of public participation - the public has a right to be informed about the work of associations of water users as a subject that participates in the use of natural resources, water as a resource of general interest to the people and the wider community;
- the principle of respect of best available techniques - for the organization of irrigation it is favored the application of best available techniques.

The current situation in the financing of irrigation in the Republic of Serbia and the Autonomous Province of Vojvodina (APV)

Although irrigation in Serbia is not legalized, state and APV (including national and provincial funds) are still allocated incentives for irrigation of land. Although national and provincial authorities paid incentives for this purpose, it can be said that the percentage of irrigated area in total arable land is very low. Data in Statistical Yearbook of the Republic of Serbia (2016) show that during 2015, the irrigated area was 54,714 hectare and makes 1.6% of total utilized agricultural area. The most common type of irrigation was artificial rain (sprinkling).

Subsidizing of irrigation in the Republic. An article 4, of the Rules on incentives for investments in agriculture for improving competitiveness and achieving quality standards through support in the primary production

of crops (Official Gazette of RS, no. 38/16) provides incentives for the purchase of new machinery and equipment for irrigation. Eligible investments include the following elements:

- irrigation pumps,
- generators that run the pumps, irrigation systems "drop by drop" with complete elements and parts, irrigation systems complete with artificial rain elements and parts, irrigation systems in order to protect from frost, irrigation systems with the possibility of fertilization and humidifying the space for micro greenhouses.

In 2016 expenditure planned budget users for water at the Ministry of agriculture and environmental protection (MPZŽS) decreased by 35.1% compared to 2015, and the planned expenditure of the Directorate for water decreased by 18.4 percentage points (Chart 1).

Chart 1. *The structure of the planned expenditure budget users for water at MPPL in the period of 2015 – 2018 years (in%)*

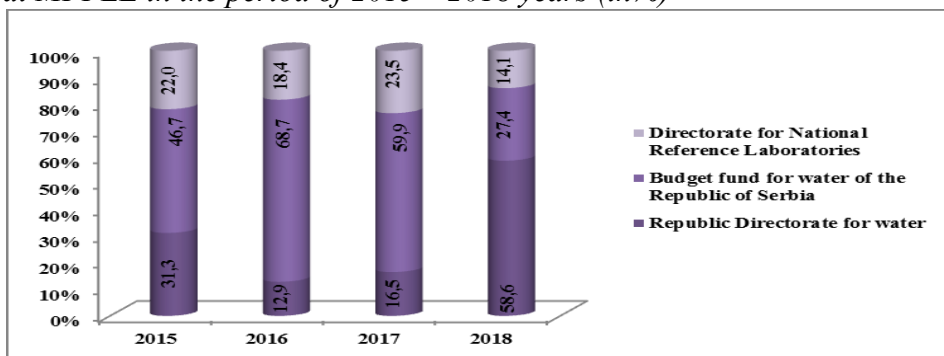

Source: *Law on Budget of the Republic of Serbia for the 2015 and the 2016, Official Gazette of RS, no. 94/2015 and 103/2015.*

The average share of the Directorate for Water in 2015-2018 amounts to 29.8%, percent of the Budget fund for water of the Republic of Serbia 50.7% and the Directorate for National Reference Laboratories 19.5%.

Subsidizing irrigation in the area of APV. According to data from the site¹⁶ intended for subsidies for co-financing the procurement of equipment for irrigation on the territory of APV in 2016. Year, funds were planned in the amount of 824.6 mln. RSD, whereby APV accounts for 235.6 mln. RSD or 28.6%. Whith investments, it is provided the irrigation of additional 5,387

¹⁶ <http://subvencije.rs/vesti/ap-vojvodina-produzen-rok-kraja-oktobra-po-konkursu-za-dodelu-bespovratnih-sredstava-za-navodnjavanje/>

ha of arable land and orchards. Total funds APV intended for co-financing of irrigation in crop production have the following structure:

- most stands out in the field of farming in the amount of 116.5 mln. RSD whereby a share of 49.4% is achieved;
- in the field of vegetable production is planned 67.8 mln. RSD whereby a share of 28.8%, is achieved, and finally
- in fruit growing are planned investments in the amount of 51.3 mln. RSD, a planned share was 21.8%.

According to contest of the Provincial Agricultural Development Fund APV for loans for the purchase of new systems and equipment for irrigation in 2016¹⁷, there are defined funds to **farms** - natural and legal persons from APV, which are subscribed in the Register of agricultural holdings. Loans will be granted on the basis of the Rules on the allocation of funds from the established criteria for the allocation of loans by the announced vacancies in 2016. Loans are granted at an interest rate of 1% per annum, with the application of the clause under the following conditions:

- The maximum loan amount is 40.000 EUR;
- Minimum loan amount 1,000 EUR;
- grace period for 12 months during the grace period is not calculated compound interest;
- repayment period of 30 months;
- the repayment shall be made in semi-annual installments, the first installment is to be paid after the expiry of a grace period (a total of 6 installments).

The loan will be implemented so by the Fund, that will pay the loan amount to the supplier whose core business is the production and sale of irrigation systems, and which is selected participant to the contest.

The Regional Fund for Agricultural Development APV is paid 2015 94,1 mln. RSD or 783,805 EUR on the basis of approved loans for irrigation, which makes 17.6% of the total funds disbursed Fund in 2015.

Conclusion

Taking into account the above-mentioned reasons, the need to improve the current situation in this area, as well as the need to improve agricultural

¹⁷ <http://subvencije.rs/vesti/ap-vojvodina-produzen-rok-kraja-oktobra-po-konkursu-za-dodelu-bespovratnih-sredstava-za-navodnjavanje/>

production, increasing the value of agricultural land as one of the most important resources of the Republic of Serbia, encouraging private initiative in this area, the legalization of irrigation is done by regulations and the constant need for drought prevention, we believe that the adoption of this law is justified and in accordance with the practice of other countries faced with the impact of drought on agricultural production.

The development in the field of irrigation through association owners or users of agricultural land in Serbia shall be subject to socio-economic developments, and will interact with the general economic development, relying on a clear commitment of the country to support and through appropriate legislative framework to enable the development of agriculture as one of the strategic industries. Establishing a legal framework, through the adoption of the new Law on water users, should provide the basis for the association of interested parties for the construction of new irrigation systems, as well as their subsequent successful functioning.

The proposed draft law with its positive effects which should be brought, certainly justify the cost that its implementation will create. The intention of the solutions contained in the proposed legislation means that any incurred costs shall be borne by people who recognize their economic interest in the establishment of these associations, who believe that such costs are justified because of their personal, business or economic interests. Irrigation development, which should enable the adoption of this law will certainly contribute to increasing the volume of agricultural production, and thus definitely and positively contribute to the budget of the Republic of Serbia. It is reduced the need for allocation of funds to cover the damage caused by drought, and final users need to enable the purchase of agricultural products at lower prices, which would contribute increasing the volume of their production. It also enables the development of modern agriculture, which involves the use of modern equipment.

Although there is support for the Republic of Serbia and the APV, it is concluded that irrigation is not sufficiently represented. Except the expensive equipment, the reason for lack of interest for this system to improve agricultural production lies in the fact that the rural population is mostly old, uneducated and without motivation to inject some new methods and technologies in their existing production system.

References

1. *How to establish a Water Users Association*, IWMI International Water Management Institute; SICWC Scientific Information Center, Interstate Commission for water coordination)
2. Official Gazette of RS, no. 94/2015, Law on Budget of the Republic of Serbia for 2015.
3. Official Gazette of RS, no. 103/2015, Law on Budget of the Republic of Serbia for the year 2016.
4. Official Gazette of RS, no. 38/16, Rules on incentives for investments in agriculture for improving competitiveness and achieving quality standards through support in the primary production of crops.
5. Republican Bureau of Statistics (2016): Statistical Yearbook of the Republic of Serbia, Belgrade.
6. The Water Sector in Germany, Johan Wackerbauer, 2011, LAW for the approval of the Government Emergency Ordinance No. 147/1999 concerning the Water Users' Associations
7. Water user associations act of Bulgaria, Закона од Јуне 6,1991. који се односи на водоуправе
8. *Water Users Association for Sustainable Water Management*, World Conference of Science contribution from International Hydrological Programme of UNESCO
9. *Water Users Association in productivity in Northern China*, Lei Zhang, Nico Heering, Liesbeth Dries, Xiaoping Shi
10. Закон о водима Републике Србије
11. <http://subvencije.rs/vesti/ap-vojvodina-produzen-rok-kraja-oktobra-po-konkursu-za-dodelu-bespovratnih-sredstava-za-navodnjavanje/>, accessed 10/25/2016.

EDUCATION AS A FACTOR OF TECHNOLOGICAL PROGRESS AND DETERMINANT OF HUMAN RESOURCES IN AGRICULTURE

Marina Novakov, Dejan Janković¹

Abstract

The paper gives an overview of the different approaches to the education and knowledge as a key resource in contemporary society that is marked by intense social changes, which strongly affect both the role and the meaning and objectives of education. The aim of the paper is the analysis of the basic features of the educational structure of the rural population of Serbia according to the Census data, as well as educational potential of farmers in Vojvodina in the context of the adoption of technological innovations. In addition, the analyses are also based on a survey conducted in 2012/2013 on a representative sample of 281 farms in Vojvodina. The results point to the conclusion that, with an adequate formal education, cooperation of farmers with extension service has significant influence on their capabilities to implement new technologies.

Key words: *education, new technologies, educational structure, rural population*

Introduction

The processes of industrialization and urban development have significantly influenced the development of the education system. Until the beginning of the 19th century most of the population had no education, however, since the industrial economy was rapidly expanding, there was a great need for specialized education and educated workforce. Given that occupations

¹ Dr Marina Novakov, researcher, dr Dejan Janković, Assistant Professor. University of Novi Sad, Faculty of Agriculture, Department of Agricultural Economics and Rural Sociology, Trg Dositeja Obradovića 8. Phone: +381214853381; e-mail: marinan@polj.uns.ac.rs; jankovic@polj.uns.ac.rs <mailto:marinan@polj.uns.ac.rs>. Paper is part of the research on the project "Sustainable agriculture and rural development in terms of the Republic of Serbia strategic goals' implementation within Danube region" (III 46006; 2011-2014), and project "Rural labor markets and rural economy of Serbia - the diversification of income and poverty reduction (ON 179028; 2011-2014).

become increasingly heterogeneous, it becomes impossible to directly transmit work skills from parents to children, as it used to be (Giddens, 2003: 496). As some authors claim "in the beginning education was almost exclusively general, the classical, in humanities, unproductive and in leisure, as it could be afforded only in the highest social classes, where it was one of the hallmarks of elite status. Then it is placed in the function of education of management elites. A crucial step in the development of education has been made when it began to systematically and continuously take place within the schools as specialized institutions where students gained knowledge and skills necessary to perform certain social roles and took social positions on the basis of verified social and professional qualifications, that implied the acquisition of knowledge and training character of people, as well. The decisive qualitative leap took place in the West after the establishment of civil society, when the rapid development of natural and technical sciences - whose results are directly applied in practice - contributed to rapid social development. Education has increasingly become massive, highly specialized and permanent. At the same time, it becomes increasingly important for the social status of individuals and social groups" (Mimica; Bogdanović, 2007: 371).

In modern societies, education is closely linked with technology, and joint with knowledge and in their mutual relation, education and technology "become increasingly important sources of social power and influence" (Marinkovic, 2008: 197). Since power is related to education and technology, in this sense, "the availability of higher education and mastering new technologies, as one of its essential consequences, has the gain of power for highly educated individuals and social groups who directly or indirectly manage technologies and technological changes. This is also a consequence of the direct impact of education on economic growth. In the global market of intellect, education, knowledge, technology and labour, individuals are no longer limited to their national governments and local territories. They increasingly work in the context of the global economy and, based on their education and technological knowledge, may gain very high rewards (economic, material, financial, political, and cultural)" (ibid: 198). Such links between education, technology and power can, however, lead to further polarization of individuals and social groups, insofar those who are available for higher education and new technologies have the ability to gain more power and influence, while the others remain deprived of those (ibid.).

Considering that education is an important segment of human capital in agriculture, the paper analyses the educational structure of the rural

population of Serbia according to the Census results, as well as the educational potential of a farmer on selected farms in Vojvodina, based on the results of survey/evaluation of work of the agricultural advisory service conducted during 2012 and 2013 on a sample of 281 farms.² The results of this survey are representative for Vojvodina and comprise farmers that cooperate with all 13 agricultural stations in extension service of Vojvodina.

Education: between reproduction of the social structure and factor of reform

Education is considered a major factor of modern social development and it has long been noticed "that our culture is characterized by excessive belief in what is called education and upbringing. This almost mythical formula has contributed to the process of education seen as a new kind of religion that should enable the achievement of the leading ideals" (Koković 1994: 108). The link between education and society is viewed mainly through two opposing theoretical orientations – according to one an education is only a mean of reproduction of the social structure, and to the second, education is capable to develop a new type of society, and it is an important factor in the reform of society (ibid: 171-172; more in Novakov; Petrović, 2012 and 2013).

The importance of quality education at the individual and societal level, and about the possibility of creating a more humane world - if it is understood the paramount importance of education – an optimism has been seen in the thesis of a “*good society*” by eminent economist John Kenneth Galbraith. Although social power is not in the hands of those who possess the education, but of those who have capital, it is the education, according to Galbraith, a key objective of a good society. In an attempt to define a good society that is potentially feasible, he points out that the essence of a good society can be simply expressed by saying that to every member of society it should be enabled to achieve a fulfilled life regardless of their gender, race or ethnic origin. In a good society, everything rests on the role of the economy, whereby the economic system must function well and to work for the benefit of all (Galbraith 2001: 26-30). According to him, the decisive importance for the good of society is education (in addition to the economy and the state that is not subordinated to the specific ideologies). Education has an economic, but also political and broader social role - it is a decisive factor to move up in the social hierarchy, its role is to enable people to behave more intelligently

² The project was financed by Provincial Secretariat of Agriculture, Water Management and Forestry. Project leader was prof. dr Živojin Petrović and coordinator dr Dejan Janković.

and to show them how to enjoy life (ibid: 63). Education affects social peace and contentment, it is “a factor that provides real hope and expectation that it is possible to escape from the lower, socially and economically subordinate classes, into upper ones. Some degree of social division into classes is in good society inevitable, as it is impossible a complete abolition of class society” (ibid: 62). Moreover, education is directly linked with democracy - not only education enables democracy, but it is an integral part since education creates a population that understands the social aims and teaches people to raise their voice. Thus, in the view of Galbraith, democracy is seen as a natural consequence of education and economic advancement; education, he says, makes democracy possible, but in the community with economic development makes it necessary, and even inevitable. Education contributes to the expansion of horizons and enjoying life, and therefore must be kept in mind when thinking about investing in the future as if nothing is as valuable with such certainty as education. However, Galbraith notes that a large part of the costs of education are understood as current consumption without consequences for the distant future, and the problem is that one needs to make a distinction between short-term and long-term goals.

The power of knowledge to create a society comes to the fore with Peter Drucker, author whom many refer to as the prophet of modern management. The knowledge society is global and Drucker describes it not only as a post-industrial, but also as post capitalistic, and as major means of production of that society he considers knowledge. Drucker assumes that in every several hundred years in the history of the West a kind of major transformation happens and now we live in a transformation that is created by post-capitalist society. Moving towards a post-capitalist society began after World War II. This society uses free market and the main economic resource is knowledge (Drucker, 1995: 7-12). "The leading social groups of the knowledge society will be 'knowledge workers' - the executive managers / users know who know how to use their skills for productive purposes" (Ibid: 13). All these workers will be employed at organizations, but knowledge workers will possess the knowledge and the means of production and tools for production, because "knowledge workers own their knowledge and they can carry it with them everywhere they go. Another class will consist of workers who do not have enough education to be knowledge workers in each country and they will provide the majority" (ibid: 14).

The knowledge that has always been a private good, overnight becomes a public good, which changed the meaning of knowledge. Today, knowledge refers to knowledge itself: it is a revolution of management; it is a factor of

production being pushed into the side of capital and labor. Land, labor and capital are important as a necessity, without which even knowledge cannot be produced, but where effective management is present (i.e. “the application of knowledge to knowledge”), Drucker believes that one can always acquire those other resources. The fact that knowledge is real and not just one of the resources, is fundamentally changing the structure of society. Traditional factors of production (labor, capital, land) have become of secondary importance, because they can be easily obtained under the condition that one has knowledge. According to Drucker, what we now consider knowledge is “information, effective in action, information focused on results”, and to get the results the knowledge has to be highly specialized. The new society must be structured on the basis of specialized knowledge and specialists, and that is exactly what gives them power (Drucker, 1995: 25-51). Knowledge is acting as an economic resource, and the main producers of wealth become knowledge and information. However, knowledge is not cheap, but as he says, developed countries spend about a fifth of GDP in production and dissemination of knowledge (ibid: 183-186). In the knowledge society, people must learn how to learn, since the post-capitalist society requires lifelong learning and for that he needed the discipline of learning (ibid: 198).

Although developed in the middle of the last century, the work of Wright Mills made a huge impact on the consideration of the relationship between knowledge and power, as well as the role of education and the reproduction of cultural capital. Unlike the classical elite theorists, who attribute the superiority of the rule of the elite to personal properties in relation to the mass, and psychological characteristics that stand out as the basis of government (Haralambos, Holborn, 2002: 601-602), Mills interprets elite rule by institutional characteristics. Thus, in the American society large-scale national power lies in the economic, political and military domain, and families, schools and religious organizations can only adapt to modern life while the government, military and commercial organizations create and direct this life (Mills, 1998: 18-19, 274 to 332). Mills is of the opinion that knowledge and power are not united in the ruling circles, and when people of knowledge come into contact with people of power, they do not approach them as equals, but as a mercenary people. Most people think that the most powerful and richest at the same time have the most knowledge, however, powerful and rich people must be people who know the most, otherwise the question arises then how could they justify their power and wealth if not with knowledge. And if it is considered that those who have gained power are undoubtedly clever, it means to say that power is knowledge. Such an assumption reveals that ordinary people tend to justify power and wealth

with knowledge and ability, and knowledge is considered more as ideal than a tool of power and wealth. Knowledge rarely gives power to the man who owns it, and how Mills states, the problem of knowledge and power is and always has been a problem of relations of the people of knowledge and people of power. Since knowledge and power are rarely united in the same person, men of power are so surrounded by people who know something, and like most other people "a man of knowledge depend on the livelihood of employment, which today represents the basic sanction for the control of thinking" (Mills, 1966: 27). As wealth is "inherited and passed along with those privileges in terms of education and social connections that became more decisive in gaining leadership positions in the business world of big, highly centralized and institutionalized capital" (Mills, 1998: 7), even social hierarchy is not based on knowledge rather than on power, and often "fathers income, more than the boy's intelligence, determine their college education" (Mills, 1979: 244).

The term "knowledge society" in particular spread to Europe after the Presidency of the European Council meeting in Lisbon in 2000 as the European Union set a major objective of a "transition to a knowledge economy and knowledge society", by which "knowledge society" became the slogan of the decade (Krištofić, 2005: 95).

In the modern world knowledge is referred to as a capital resource, or in the words of Conrad P. Liessman the euphemism "knowledge society" and "we live in a knowledge society" is a sentence that increasingly "encourages" bearers of social power (Liessmann, 2008: 7). He warns that what is on the scene is the capitalization of the spirit which is rushing into illiteracy, a "knowledge society" is nothing but a worthless demagogic platitude. In his opinion, similar to the Wright Mills, intellectuals have a great responsibility because they adopt or behave according to political decisions and silently accept the orders of the authorities and educational policy makers. As knowledge and education are emphasized in the public discourse as Europe's most important resources, and considered as a stake for the future, Liessman notes that more and more the end of industrial work is evoked, and a focus is "knowledge-based" occupations. Flexible individual ready to learn all his life - that is necessary for knowledge society - makes their cognitive abilities available to the (rapidly changing) markets and, according to Liessman, this individual is no longer even "a caricature of a humanistic educated man" (ibid: 8). For Liessman, knowledge is "more than information". Similarly, knowledge cannot be managed and educational institutions cannot be service companies. He states that from the claims of P. Drucker follows that

whoever finds himself at the bottom of the social scale, was simply “too little, too slowly or wrongly taught”. Market relations and technical innovations are changing rapidly and the ideology of lifelong learning does not serve only that many, especially the elderly, may be forced too much, *but to attribute to the individuals these risks of development*. Education has become an ideology of secular societies and consolation for the losers of modernization, it acts as a stimulant and a sedative, a knowledge-based society does not replace the industrial society, but industrializes knowledge (ibid: 27-44).

Standpoint of reproducing power of the ruling class through the educational system represents the French sociologist Pierre Bourdieu. According to Bourdieu, the main sources of social power are the economic capital in its various forms, cultural capital, and symbolic capital – “forms which take different types of capital when they are meet and recognized as legitimate”. In economically developed societies, economic and cultural factors have the greatest power of distinguishing between people (Bourdieu, 1998: 147,151,154) and the objective power relations tend to be reproduced in the relations of symbolic power. Bourdieu argues that in society there are always conflicts between symbolic power and symbolic power is the power of creation of the world. Bourdieu's concept of education provided insight into the understanding of the role of education in the reproduction of social inequality. He thinks that for the failure of the working class the education system is to be blamed because it is biased towards a culture of ruling social classes and serves its reproduction, since the ruling classes have the power to impose certain meanings as legitimate and to impose their definition of reality. According to Bourdieu, the dominant culture refers as the cultural capital because “through the education system it can be translated into wealth and power” (Haralambos, Holborn, 2002: 837). Bourdieu thinks that education system is one of the factors of social conservatism because it legitimizes social inequality and cultural heritage is different in different social classes, and is responsible for the initial inequality of children and their unequal success in school. The starting position from which children from different social classes are included in the education system are very different because the specific cultural capital is gained within the family (Bourdieu, 1967: 263-264 by: Koković 1994: 161.238). Since individuals already have starting position with which to engage in unequal educational process, it is similar with the claim of Wright Mills (speaking on the reproduction of the ruling class), that everything is easier if you are already born at the top.

Technology and global (environmental) risks

New scientific technologies affect everyone - families, farmers all over the world, they change working contingents. Technological changes have caused that two main components - the socializing and development one - which traditionally belonged to education, gain in importance in parallel with the progress of society, especially civil society. It might even be said that “in the third technological revolution, they become in some way crucial to the fate of certain countries and the world as a whole” (Koković, 2009: 253).

Globalization accompanied by new computer technology affects the future of the workers in all segments of the economy. Technological development, as is often cited in the literature, has already squeezed out of work millions of workers and made the whole working class to disappear. In agriculture, production and services human workforce is rapidly replaced with machines, and some of the most impressive innovations in automation have occurred in agriculture. Technological changes cause consequences for over two billion people whose livelihoods depend on agriculture. Mechanical, biological and chemical revolution in agriculture, according to Jeremy Rifkin (2003), have made farmers in Israel on their way to cultivate land by using the robot, and the Institute for Agricultural Engineering develops a “mechanical farmers”. Similar robots with artificial intelligence are developed to plow and sow the fields, and researchers predict that we are less than twenty years away from fully automated farms. New genetic technology that changes the method of obtaining plants and animals increases production, but in order to cut the costs of use of insecticide and manpower required to monitor crops, scientists directly injected genes in the genetic structure of plants in order to be resistant to pests (Rifkin, 2003: 128). Genetic engineering is also used to reduce the need for labor in animal husbandry and increase productivity. Biotechnology, which is propagated as the almighty cure for diseases and food supply, expands man's dominion over the forces of nature more than any other technology in history. By merging genes together researchers have created the “geep” (half goat – half sheep), changing plants mainly to extend their shelf life and improve the appearance, not their nutrition value. The authors warn of the possibility of health problems and products like tomato that contains a gene resistant to antibiotics, according to the Kimberley, could produce resistance of children on the common antibiotics that are used for their health treatments (Kimbrel, 2003: 157-176).

Vandana Shiva considers that the only determinant of power and control in a globalized world is economic power. Corporations have the power; the rules of free trade allow corporations to use the machinery of the national state to achieve their goals, and for some “sustainable development” simply means the conversion of the ecological crisis in the trade with deficit resources (Shiva, 2003: 165) Although declaratively many are worried about environment, climate change etc., the fact remains that there is an increasing growth of the energy consumed in the transport, packaging, manufacturing, and “a chicken travel on average 2,000 kilometers before it is eaten” (ibid: 152) . Globalization destroys both ethical and environmental obstacles of business, and since everything can be traded - everything is for sale.

In the context of the environmental dimension of globalization, the idea of risk, pointed out Ulrich Beck who (in the definition of globalization), argues that it “means the processes that have consequences that transnational actors, their chances of power, orientations, identities and networks undermine national states and their sovereignty and are connected to each other” (Beck, 2003: 28). He believes that social production of goods is systematically followed by social production of risk, and a risk society is a society in which there is a threat that state of emergency becomes normal (Beck 2001: 31,37). “Dealing with the risks of civilization, science has always left their basis of experimental logic and entered the polygamous marriage with the economy, politics and ethics - or more precisely: they live with them in a kind of “lasting marriage without marriage certificate” (Beck 2001: 45).

Considering the impact of globalization on our lives, Anthony Giddens states that some influences of which are expected to make our life more certain and predictable (including scientific and technological progress) have often the opposite effect. Science and technology became globalized, and it has been calculated that today more scientists are engaged than ever before in the history of science. Global changes are result of our impact on the environment, and science and technology are helping to confront the dangers even though they have contributed to their very inception. Science has long maintained “the image of knowledge reliability that has evolved in an attitude of respect towards most forms of technical specialties. However, at the same time, attitudes of laics towards science and technical knowledge are usually ambivalent” (Giddens 1998: 92). Ambivalence is the basis of all relationships of trust because the trust is required where there is ignorance and ignorance always provides grounds for skepticism or caution. Many people so “bargain with modernity, in the sense of trust that invest in symbolic characters and expert systems” (Ibid.).

Basic indicators of the educational structure of the rural population in Serbia

Modern society is marked by intense social changes which strongly affect the meaning and aims of education (Koković, 1994). Education as one of the traditional functions of the family has moved on to agencies and institutions, and the relationship of rural children to the education has varied throughout history, and to the role of education in modern society, as well.

In Serbian history, literacy was often a feature of men. According to the census of 1866, at the end of the 19th century Serbia had less than 5% of literate population, and especially small literacy was in villages - only 1.36%. The next census in 1874 has shown a rise due to the fact that in the interim period 139 primary schools were opened, and the number of schools increased from 373 to 517³ (Isić, 2001: 12). Although slow, in the late 19th century literacy in Serbia has risen steadily, especially in the male population. Literacy of the population before the First World War remained a mystery because the question was how many of them were actually literate, because not everybody registered as literate in 1866 really knew to write (ibid: 24). The impact of the First World War on the development of literacy in Serbia was long-lasting. Momcilo Isić informs us that in the spirit of the policy of denationalization, the occupations forces have specially destroyed the schools during the war, that in many areas were actually the only source of literacy, culture and national consciousness. Also, the war has caused a lack of teaching staff that Serbia lacked even in pre-war period (ibid: 25,35). Because of the many casualties in this period, primary school child was an important economic factor, and in many rural households was the only workforce. In addition, the impoverished rural households were not able to provide children with basic needs for education and many of them didn't attend school. Out of education were especially female children because they remained in the village in accordance with their social role (the role of mother, wife, housewife), that didn't require education. The Law on public schools in 1929/1930, stipulates compulsory primary education throughout the Kingdom of Yugoslavia. What was required by the Law, was difficult to realize because the large agricultural crisis caused a decline in economic power of farmers (Isić, 2001: 68). Higher literacy rates followed thirty years after the war, and in later periods men retained a better educational structure than rural women.

³ Today (2016) there are 3.385 primary schools in R. Serbia.

Seen from the mid 20th century, the share of illiterate persons in the total population aged 10 and more in Serbia was constantly decreasing and in 2016 it is 1.96% (compared to 27.91% in 1953 and 10.86% in 1981 and 3.45% in 2002). In addition, 82% of women are illiterate, and $\frac{3}{4}$ or illiterate are aged 60 and over (2011 Census Atlas, 2014: 38). This decline in the number of illiterate is largely the result of the natural dying out of the older population. In rural areas the situation is worse: 3.31% illiterate, while from the total male population older than 10 years, 1.13% are illiterate, while the share of illiterate women is five times higher (5.48%).

Educational structure of the rural population in 2011 (Table 1) shows that the most common is high school degree of education among the rural population (42.37%). In second place is elementary education (27.68%), while only 6.1% of rural inhabitants have higher or university education. Total share of the population that has a lower level of high school education is 51.1%, which decreased by 12.7% compared to the period from the beginning of this century (2002 Census). However, it is also twice as many persons with lower levels of education than in urban areas (22.98%). In the villages of Šumadija and Western Serbia, as well as Southern and Eastern Serbia, the educational structure is worse than in Vojvodina and Belgrade.

Censuses also record gender inequality in the educational structure. However, the attitude of the peasants towards the education of male and female children has partially changed. Education requires large financial resources for rural children, it often involves walking long distances to school, but, according to the A. Milic, parents by force accept social tendency of schooling and education of children. But no matter how this parent's commitment looked modern, it hides in the reshaped form some traditional views. This is particularly evident with the education of female children. If parents in rural areas make decisions it will more likely be the education of women/girls rather than men/boys usually due to old tradition of dowry. It was expected/required that parents provide to a female child "good" marriage chance, and it would be best to do if female children have as much education" (Milić, 1986: 118). At the same time, young people see education as an opportunity to escape from agriculture and rural areas, and the most educated among them, even those who study agriculture, after education prefer to stay in the city (Jankovic, Novakov, 2012).

Table 1. The educational structure of the rural population aged 15 and over in 2011 (%)

Education	Serbia North regions				Serbia South regions				R. of Serbia	
	Belgrade		Vojvodina		Šumadija and West Serbia		South and East Serbia		No	% in total
	No	% in total	No	% in total	No	% in total	No	% in total		
1. Without education	6579	2,46	22965	3,41	45317	4,94	35925	5,51	110786	4,41
2. Incomplete primary ed.	25192	9,43	106527	15,83	193370	21,08	151860	23,30	476949	19,01
3. Primary education	61862	23,15	185373	27,54	259148	28,25	188097	28,86	694480	27,68
4. Secondary education	147503	55,19	311510	46,28	364882	39,78	239282	36,72	1063177	42,37
Gymnasium	7625	2,85	18891	2,81	19062	2,08	13338	2,05	58916	2,35
Secondary less than 4 years	68108	25,48	153745	22,84	191149	20,84	122786	18,84	53788	21,35
Secondary 4 years	67822	25,38	135584	20,14	149929	16,34	99825	15,32	453160	18,06
Specialization	3948	1,48	3290	0,49	4742	0,52	3333	0,51	15313	0,61
5. Higher education	12108	4,53	20338	3,02	24440	2,66	16874	2,59	73760	2,94
6. High education	12673	4,74	24822	3,69	26473	2,89	15343	2,35	79311	3,16
7. Unknown	1339	0,50	1525	0,23	3681	0,40	4324	0,66	10869	0,43
TOTAL	267256	100	673060	100	917311	100	651705	100	2509332	100

Source: Census book 3 (2013): 34-79 and authors' calculation

Also, the share of young people in rural areas in the total highly educated unemployed amounts to 18.83% (Labour Force Survey 2014, 2015: 51). An increase of education of rural women can be seen in last Census data (Graph 1). Data show somewhat greater share of women in rural areas in

higher education (3.22%) than men (3.1%), which is a novelty in comparison to the 2002 Census when share of highly educated men was 1.8% and woman 1.23% in rural areas. Men dominate in the category of secondary education (48.93%) while the share of women is significantly lower (35.84%). The category of incomplete primary and the primary school level is almost the same in both sexes, while gender disproportion is present in the category of persons without any education. Thus, among them are four times more women. It is noteworthy that the comparison of young people at national level (15 to 30 years of age) by sex in both Censuses of the 21st century, shows that women had higher stakes in the category of high education while men dominated in other categories (Bubalo-Zivkovic, Lukić, 2015: 111).

Graph 1. *The educational structure of the rural population in the Republic of Serbia by gender (%)*

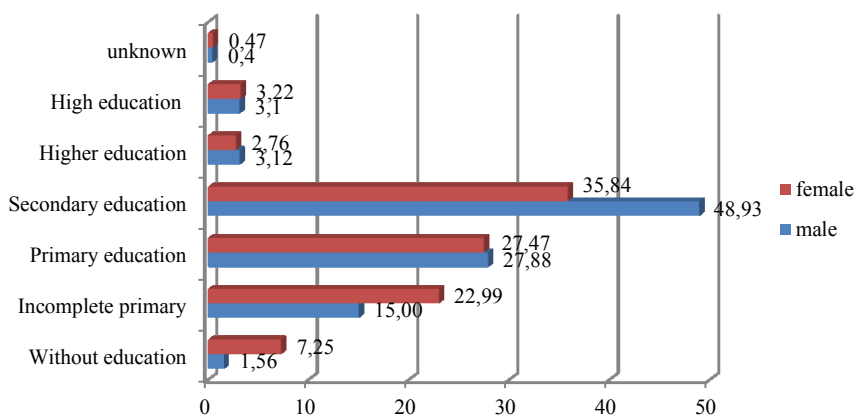

Source: *Census, book 3 (2013):34 and authors' calculation*

In today's world of sophisticated technology literacy of the population relates primarily to computer literacy, which become a necessity in different segments of life and work. As a result of the process of globalization, mass computer literacy in Serbia has begun in the 21st century, a Census 2011 is the first that records this form of literacy. After examining the results (Graph 2) it is evident that there are much more computer literate in urban (44.09%) than in rural areas (19.84%), but without gender inequality.

Graph 2. Computer literacy according to sex and settlement (%)

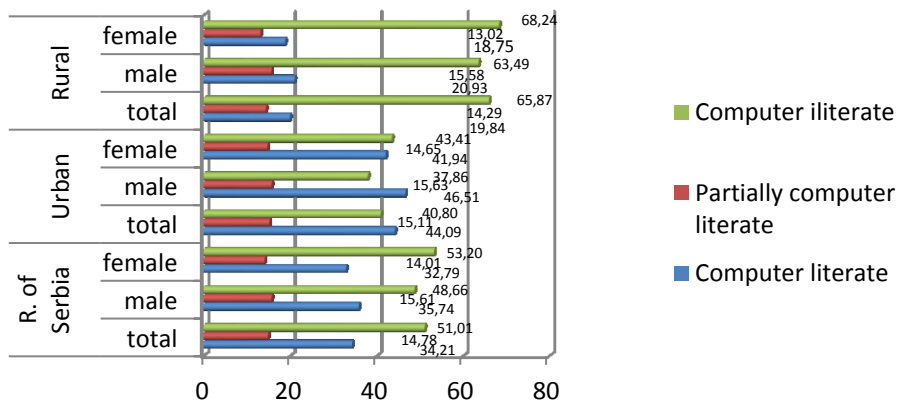

Source: Census, book 3 (2013):140 and authors' calculation

The educational potential of farmers at selected farms and acceptance of new technologies

The scientific and technical revolution had a decisive influence on the process of industrialization of society and modernization of agriculture through numerous innovations that have occurred particularly in the last hundred years. It turned out that the willingness of farmers to adopt an innovation depends on the characteristics of local communities, households and farms, as well as the farmer's personal traits. As a rule, innovation is higher if the householder is more educated and if he lives in the more developed areas. In addition to the educational level, family background, spatial mobility and exposure to mass communication has impact on the adoption of innovations (Mitrović,1998: 360,361). Accordingly, at this point we will mention some characteristics of farmers on selected farms in the north region (Vojvodina), which may be of importance for their attitude towards the acceptance of innovations in agricultural production.

The largest numbers of farmers in our representative sample in Vojvodina have completed secondary education (62.3%), which corresponded to the Census data on educational level on the territory of both R. of Serbia and Vojvodina. However, the educational structure of farmers in our sample is slightly more favorable than of the total rural population. Thus, 19.9% of farmers have incomplete primary or primary school, while the shares of persons in rural areas in Vojvodina that have a lower level of education than high school is 46.78%. Higher education has 7.8% and high

education every tenth farmer. There is a high and statistically significant medium strong correlation between education and age of farmers ($\chi^2=56,229$; $p=0,000$; $C=0,408$), but no between this variable and gender ($\chi^2=1,547$; $p=0,818$). It turned out so that the lower level of secondary education is the most common among the oldest farmers (65+ years).

In regards to a computer literacy, the situation is as follows: 88.6% have a computer in their household, and 69.8% of farmers know how to use it. As expected, as the level of educational increases the share of knowledge to use a computer rises, so there is a statistically significant relationship (middle strong) between these variables ($\chi^2=40,916$; $p=0,000$; $C=0,357$). The computer and the internet are in approximately the same percentage used to communicate by e-mail (25.3%), and entertainment and leisure (26.7%). More than half responded that they use computer for work and learning (61.2%). Facebook is used by 11% of farmers, Twitter 1.8%, MSN 1.1% and MySpace 2.1%. 11.4% responded using a computer for communication via Skype.

The perception of the importance of education to succeed in life is high (Graph 3). Thus, 35.9% of farmers considered education as very important to have success in life, as important 45.2%. Kruskal-Walis test ($p=0.252$) indicates that there is no statistically significant relationship between variable of the importance of education and the achieved level of education.

Graph 3. Importance of education for life success (%)

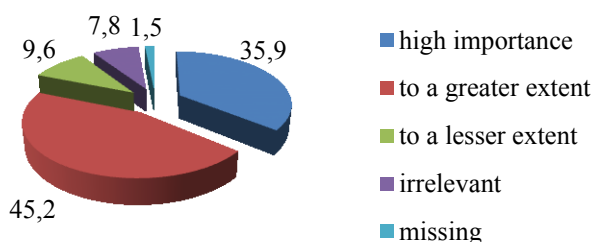

Source: Evaluation of work of extension service on selected farms in Vojvodina

Also, according to Mann-Whitney U test, no statistically significant relationship between the variables of gender and the importance of education has been found ($U=1407$; $z=-1.608$; $p=0.108$). In addition to education as an important segment of social capital, kinship and friendship are considered in almost identical percentage as very significant (34.2%) and significant to a greater extent (43.4%) for life

success. Family capital - in terms of wealth and reputation of the family - is perceived as very important (31%) and significant to a greater extent (40.6%) for life success.

Of our research interest was also how much importance is attached to cooperation with the extension service for the use of new technologies in the production (Graph 4). The largest percentage of farmers (74%) agrees that as a result of cooperation with extension service they are able to apply new technologies. Among farmers who have expressed their disagreement with this statement, as the reason for disagreement were: that they already use the proven technology; that they themselves contributed to their skills; that extension workers didn't inform them about it; or that they have no money for new technologies. Kruskal-Walis test indicates that there is a statistically significant relationship between the variables of agreement with that attitude and satisfaction with the cooperation with extension workers ($p = 0.000$), as well as with the length of this cooperation ($p = 0.007$). Thus, the highest agreement with this attitude was among the farmers who have declared that they are satisfied with cooperation with extension workers (86.5% of this category), and where this cooperation lasted 4 years and more (80.2% of this category).

Graph 4. *“As a result of cooperation with the extension service I consider myself qualified to apply new technologies on my farm” (%)*

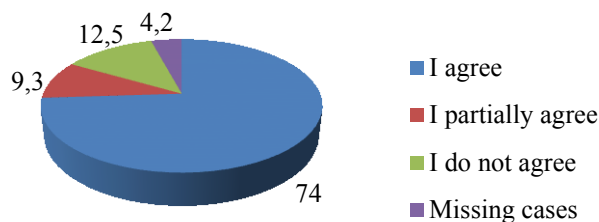

Source: *Evaluation of work of extension service on selected farms in Vojvodina*

Conclusion

In order to be in line with the requirements of scientific and technological revolution education has experienced rapid and powerful changes in the objectives, policies and methods of operation. Permanent education in the era of scientific and technical revolution becomes so imminent because “science and technology is developing at a rate that already in the life of one generation it comes to the obsolescence of knowledge. The speed of economy changes makes unrealistic all attempts to provide conclusions in

a decade advance about the demand for certain qualifications. Education systems and institutions need to have their internal structure enough flexible to move students among the disciplines and types of education necessary to cope with changing technology and demands of a constantly changing economy” (Koković, 2009: 255).

The same is true for education in agriculture. In fact, when it comes to agriculture and human resources, it is emphasized that investment in the increase in the level of knowledge of the agricultural population, which has an unfavorable educational structure, largely determines the future prospects of agriculture, and thus the economy as a whole. The cooperation of Serbian farmers with experts in the field of agriculture, jointly with adequate formal education, has a significant impact on their ability to apply new technologies, so the role of extension services can be of great importance in overcoming the shortcomings of the educational system that does not meet the modern needs of the development of Serbian agriculture.

Literature

1. *Anketa o radnoj snazi u Republici Srbiji.* (2015). RZS. Beograd.
2. Beck, Ulrich (2003). *Što je globalizacija.* Vizura. Zagreb.
3. Bek, Ulrih (2001). *Rizično društvo.* Filip Višnjić. Beograd.
4. Bubalo-Živković, Milka; Lukić, Tamara (2015). *Mladi u Srbiji početkom 21. veka.* RZS. Beograd.
5. Burdije, Pjer (1998). *Društveni prostor i simbolička moć.* u: Spasić, Ivana (priredila) (1998) *Interpretativna sociologija.* Zavod za udžbenike i nastavna sredstva. Beograd.
6. Burdije, Pjer (1999). *Nacrt za jednu teoriju prakse.* Zavod za udžbenike i nastavna sredstva. Beograd.
7. Drucker, Peter (1995). *Postkapitalističko društvo.* Poslovni sistem Grmeč-Privredni pregled. Beograd.
8. Galbraith, John Kenneth (2001). *Dobro društvo. Humani redosled.* Grmeč i Privredni pregled. Beograd.

9. Giddens, Anthony (2003). *Sociologija*. Ekonomski fakultet. Beograd.
10. Giddens, Anthony (1998). *Posledice modernosti*. Filip Višnjić. Beograd.
11. Haralambos, Michael; Holborn, Martin (2002). *Sociologija - teme i perspektive*. Golden marketing. Zagreb.
12. Isić, Momčilo (2001). *Pismenost u Srbiji između dva svetska rata*. Institut za noviju istoriju Srbije. Beograd.
13. Janković D.; Novakov M. (2012) *Empoyment in agriculture and life in rural areas? Migration preferences of agricultural students*. International scientific meeting: Sustainable agriculture and rural development in terms of the Republic of Serbia strategic goals realization within the Danube region- preservation of rural values. Thematic Proceedings. Decembar 6-8 th, Tara- Serbia. ISBN: 978-86-6269-018-0, COBISS.SR-ID195237900, p.206-224.
14. Kimbrel, Endru (2003). *Biokolonizacija*. U: Mander , Džeri; Goldsmit, Edvard (prir.) (2003) *Globalizacija – argumenti protiv*. Clio. Beograd.
15. Koković, Dragan (1994). *Sociologija obrazovanja*. Matica srpska. Novi Sad.
16. Koković, Dragan (2009). *Društvo i obrazovni kapital*. Mediterran publishing. Novi Sad.
17. Krištofić, Branimir (2005). *Inovacije u ''društvu znanja''*. U: Prpić, Katarina (2005) *Elite znanja u društvu (ne) znanja*. Institut za društvena istraživanja. Zagreb.
18. Liessmann, Konrad Paul (2008). *Teorija neobrazovanosti: zablude društva znanja*. Jesenski i Turk. Zagreb.
19. Marinković, Dušan (2008). *Uvod u sociologiju*. Mediterran publishing. Novi Sad.
20. Milić, Anđelka (1986). *Seoska porodica u procesu menjanja*. ZMS DN, broj 81. Matica Srpska. Novi Sad.

21. Mills, Charles Wright (1966). *Znanje i moć*. Vuk Karadžić. Beograd.
22. Mills, Charles Wright (1979). *Beli ovratnik*. Naprijed. Zagreb.
23. Mills, Charles Wright (1998). *Elita vlasti*. Plato. Beograd.
24. Mimica, Aljoša; Bogdanović, Marija (prir.) (2007). *Sociološki rečnik*. Zavod za udžbenike. Beograd.
25. Mitrović, Milovan (1998). *Sociologija sela*. SSD. Beograd.
26. Novakov, M., Petrović Ž. (2012). *Znanje i moć u doba globalizacije*. Agroekonomika. Broj 53-54. Poljoprivredni fakultet Novi Sad, str. 96-107.
27. Novakov M., Petrović Ž. (2013). *Uloga znanja u promenama savremenog društva*. ZMS DN. Br. 145. Matica srpska. Novi Sad.
28. Popis stanovništva, knjiga 3 (2013). *Školska sprema, pismenost i kompjuterska pismenost*. RZS. Beograd.
29. Popisa stanovništva 2002, knjiga 4 (2003). *Školska sprema i pismenost*. RZS. Beograd.
30. *Popisni atlas 2011* (2014). RZS. Beograd.
31. Rifkin, Džeremi (2003). *Nova tehnologija i kraj radnim mestima*. u: Mander; Goldsmit (priredili) (2003) *Globalizacija – argumenti protiv*. Clio. Beograd.
32. Shiva, Vandana (2003). *Svet na ivici*. U: Haton, Vil; Gidens Entoni (2003) (prir.) *Na ivici. Živeti sa globalnim kapitalizmom*. Plato. Beograd.

THE POSSIBILITY OF ESTABLISHING SHORT ROTATION COPPICES FOR ENERGY PURPOSES IN THE KOLUBARA DISTRICT

Mihailo Ratknić, Sonja Braunović¹

Abstract

The use of wood as a source of energy is growing with the growth of the world's population. Therefore, short rotation coppices established for energy purposes are regarded as good long-term investments. The case of the Kolubara District in Serbia was used to present the process of determining the sites suitable for the establishment of short rotation intensive cultures. We defined the factors that affect their establishment and classified them into two groups: natural conditions and infrastructure requirements. The group of natural elements included the study of climate and micro-climate conditions, soil, altitude, land use and slope of the terrain, while infrastructure requirements referred to the accessibility of road infrastructure and the distance from watercourses. The results show the area, structure and suitability of land (highly suitable, suitable, moderately to poorly suitable, conditionally suitable) in the Kolubara District for the establishment of short rotation coppices for energy purposes.

Key words: *Serbia, the Kolubara District, short rotation coppices, potential sites, energy source, suitability*

Introduction

Wood and wood biomass are of the utmost importance for mankind. The use of wood as a source of energy is growing with the growth of world's population. This type of energy is particularly important in developing countries. It is estimated that about 2.4 billion people rely on it as the primary source of energy (IEA, 1998). About 40% of the world's

¹ Dr Mihailo Ratknić, Senior Research Fellow, Institute of Forestry, Belgrade, Kneza Višeslava Sreet no. 3, 11000 Belgrade, Serbia, E-mail: mihailoratknic@yahoo.com;
Dr Sonja Braunović, Research Fellow, Institute of Forestry, Belgrade, Kneza Višeslava Sreet no. 3, 11000 Belgrade, Serbia, E-mail: sonjabraunovic@yahoo.com

population, mostly in Africa and India, still use wood as the only source of energy for cooking (U.S.Energy, 2012).

The Republic of Serbia has an obligation to meet the defined national target of 27% share of the energy from renewable sources in the gross final energy consumption before 2020. As wood participates with 14% in the final energy consumption, it will obviously continue to be the main source of renewable energy in Serbia. Wood is used not only for energy purposes, but also for the purposes of wood industry (furniture, timber, furniture parts, etc.). This causes additional pressure on this resource which is currently at the upper limit of sustainability in Serbia.

The decline of natural forests, which has had increasingly drastic effects on the human environment (particularly in highly developed countries), has significantly intensified the research aimed at finding opportunities for higher (purposeful) wood production in short rotation intensive cultures.

In the last ten years, the market of biomass has recorded a rapid growth. The use of biomass to produce energy for heating and electricity production or liquid fuels accounts for about 14% of the world energy production. About 25% of it is used in developed countries and the remaining 75% in developing countries (Parikka, 2004).

With the adoption of the Kyoto Protocol under the Convention on Climate Change (United Nations Framework Convention on Climate Change UNFCCC), the Parties have assumed obligations to stabilize the concentration of greenhouse gases in the atmosphere, thus taking part in resolving this very important global problem. CO₂ emissions from combustion of the fuels based on wood biomass are neutral due to the fact that in the process of photosynthesis other trees absorb CO₂ emitted by the combustion. Therefore, the use of biomass for energy purposes contributes to the reduction of CO₂ emissions, on the one hand, and to the storage of carbon in forests and forest plantations, on the other hand. There is no single solution to the problem of greenhouse gases, but wood fuels are certainly one of the ways to reduce their emissions into the atmosphere (Hagauer, 2007).

The activities aimed at increasing the production of renewable energy are now linking the energy sector with the timber sector and encouraging competition and demand for wood. Consequently, energy and timber

industries are beginning to compete for wood biomass, rapidly increasing the quantities that are being utilized and traded with.

Short rotation coppices for energy purposes are established with the aim of reducing the volume of harvesting in natural forests and thus conserving natural forest ecosystems and promoting their multiple benefits.

Study area

The Kolubara District lies in the north-west of Serbia and includes: City of Valjevo with the municipalities of Ub, Lajkovac, Mionica, Ljig and Osečina. It covers an area of 2474km² (Maps 1 and 2). According to the 2011 census, it had a population of 174 228. Its administrative center is Valjevo, located on the banks of the Kolubara river. Besides the Kolubara river, its hydrographic network is made of the following rivers: Obnica, Jablanica, Gradac, Ribnica, Ljig, Peštan, Ub, Tamnava-Koceljeva, Tamnava and numerous smaller tributaries. The altitude ranges from 44 meters above sea level (municipality of Lajkovac), up to 1223 m above sea level (the city of Valjevo). There are highways and regional roads passing through the district and it has a developed network of local roads.

The Kolubara District is exposed to a large number of pollutants. Pollution of air, water, and soil has been caused by the activities in mining and metallurgy (exploitation of coal in Kolubara and Tamnava coal basin - 'Tamnava – West', exploitation of clay in Koceljeva, Ub and Valjevo, exploitation of gravel, quartz sand, stone, granite and limestone in Podbukovi), industry (construction industry and home appliance industry in Valjevo), transport (around the roads of categories I and II, especially in urban centers), energy production (heating plants and individual combustion chambers in all urban centers), problems in utility infrastructure (in all municipalities/cities; since there are no regional landfills, unselected municipal waste and hazardous waste are disposed on non-sanitary waste landfills, while the wastewater from industry and settlements flows without prior purification into the recipient rivers: Ljig, Ub, Tamnava and Kolubara downstream of Lajkovac).

Open pit mines have destroyed natural vegetation and dramatically changed land characteristics on a substantial portion of the area. The by-products of lignite burning in thermal power plants, particularly solid deposits, pollute the environment and significantly deteriorate the primary natural conditions for the development of vegetation. There is also the problem of excessive

pollution from TPP Kolubara (Veliki Crljeni). Taking into account all these problems and the ensuing pollution, the Kolubara District is suitable for the establishment of short rotation coppices.

Maps 1 and 2. The location of the Kolubara District in Serbia and its municipalities



Determination of sites potentially suitable for the establishment of short rotation coppice plantations

In order to determine potential sites for the establishment of short rotation coppices, we defined the factors that affect their establishment and classified them into two groups: natural conditions and infrastructure requirements. Natural conditions included:

- climate and microclimate characteristics
- land use based on CORINE data
- slope of the terrain - divided into three groups (0-8%; 8-12% and 12-15%)
- soil (we defined the types of soil, their limitations, productivity and suitability for the establishment)
- altitude - divided into four zones (up to 150 meters, from 150 to 300 meters, from 300 to 500 meters and over 500 meters)
- biodiversity status - excluding all sites that belong to protected natural areas or the areas that are on Natura 2000 habitat list.

Infrastructure requirements included:

- distance from the market,
- access to road infrastructure

- distance from watercourses and
- the availability and utilization of planting and harvesting machinery.

Climate and microclimate characteristics

The area of the Kolubara District belongs to region (A) (Ducić, M., Radovanović, M., 2005) and sub-regions A-1-a and A-2-a.

Climate sub-region A-1-a covers 142 255 hectares, or 57.5% of the study area. Absolute extreme air temperatures in this sub-region range from -32.6°C do 42.3° C. The annual temperature amplitude is above 22.0° C. The mean winter temperature is above 1° C and the summer mean is above 20° C. Spring temperatures are slightly different from the temperatures in autumn. The mean annual sum of precipitation in lowland areas is 520 mm, reaching more than 650 mm in some areas. The smallest amount of rainfall falls in winter, while springs have slightly higher amounts of rainfall than autumns. Climate sub-region A-2-a covers 105 146 hectares, or 42.5% of the study area. The mean air temperatures in this sub-group range from 7.0°C to 9.3°C. The mean air temperature in the hottest month does not exceed 18.4°C in the mountains and the annual amplitude is below 20°C. This sub-region is characterized by a very strong influence of topography on the amount of rainfall, so that the weather stations at the altitudes below 1,000 m have an average sum of precipitation over 1,000 mm.

Soil

Short rotation coppice species have no specific requirements in terms of soil fertility. However, yields are better on the soils characterized by higher fertility.

Automorphic undeveloped soils (Lithosol, Regosol and Arenosol) have significant limitations. They are poorly to moderately productive and not suitable for the establishment of short rotation coppice plantations. Colluvium is characterized by moderate to significant limitations. It can be conditionally productive and it is not suitable for the establishment of SRC plantations (Tables 1 and 2).

Table 1. Suitability of automorphic soils

Soil type	Degree of Limitation	Productivity	Suitable for the establishment
II – A-C or A-R (Humus - accumulative)			
Smonitza (Vertisol)	Moderate limitations	Highly productive	YES
III – A-(B)-C or A-(B)-R (Cambic)			
Eutric cambisol (Brown forest soil)	Moderate limitations	Productive soil	YES
Distric brown or Acid brown (Distric cambisol)	Significant limitations	Poorly to moderately productive	YES
Brown soil on limestone and dolomite (Calcocambisol)	Significant limitations	Poorly to moderately productive	YES
IV – A-E-B-C or A-E-B-R (Eluvial-illuvial)			
Illimerized or loessivized soil (Luvisol)	Moderate limitations	Highly productive	YES

Source: Original

Humus-accumulative soils (Calcomelanosol, Rendzina, Eutric ranker and Distric ranker) have moderate to significant limitations. They are conditionally productive and not suitable for the establishment of SRC plantations.

Table 2. Suitability of Automorphic soils (Anthropogenic and Technogenic soils)

Soil type	Degree of limitation	Productivity	Suitable for the establishment
V – P-C (Anthropogenic)			
Rigosol or Anthropogenic rigosand	Moderate to significant limitations	Conditionally productive	Conditionally
VI – Tehnogenic I, II, III			
Disposal site soil (Deposol)	Moderate to significant limitations	Conditionally productive	Conditionally
Wastewater deposits (Flotisol)	Moderate to significant limitations	Conditionally productive	Conditionally
Air precipitates (Aeroprecipitats)	Moderate to significant limitations	Conditionally productive	Conditionally

Source: Original

Cambic soils, represented by Terra rosa, have significant limitations. They are poorly productive and not suitable for the establishment of SRC plantations. Eluvial-illuvial soils (Podzol and Brunipodzol) have significant limitations. They are poorly productive and not suitable for the establishment of SRC plantations. Marsh gleys and peat (high peat, peat and transitional peat from low peat to Planohistosol) have significant limitations. They are poorly to moderately productive and not suitable for the establishment of SRC plantations. Halomorphic soils have significant limitations. They are poorly productive and not suitable for the establishment of SRC plantations (Table 3).

Table 3. *Suitability of Hydromorphic soils*

Soil type	Degree of limitation	Productivity	Suitable for the establishment
I – A-E/g-Bg-C (Pseudogley)			
Pseudogley	Moderate to significant limitations	Conditionally productive	Conditionally
II – Layers (A)-G or (A)-C (Undeveloped)			
Fluvial or alluvial (Fluvisol)	No limitations to severe limitations	They can conditionally be very productive (amelioration)	Conditionally
III – A-C-G – (Semigley)			
Fluvial meadow (Humofluvisol)	Moderate limitations	Highly productive	YES
IV – A-G (Gley)			
Marsh black soil (Humogley)	No limitations to severe limitations	They can conditionally be very productive (amelioration)	Conditionally

Source: *Original*

According to the presented degree of limitations and productivity, the area of the Kolubara District suitable for the establishment of short rotation coppices covers 12,756.3 hectares, conditionally suitable are 25,539.4 hectares and 1,241.0 hectares are unsuitable.

Orographic conditions

Short rotation coppices for energy purposes should not be established on the sites above 500 meters above sea level due to the shorter duration of the growing season. The slope of the terrain is divided into three classes: from 0 to 8%, from 8 to 12% and from 12 to 15% (Table 4, Maps 3 and 4).

Table 4. Suitability according to altitude and slope

Altitude (m)	Suitability	Area (ha)	Slope	Area (ha)
Lower than 150	Highly suitable	1,340.2	0-8°	25,759.5
From 150 to 300	Suitable	14,647.3	8-12°	8,890.3
From 300 to 500	Moderately suitable	8,942.6	12-15°	3,689.9
Above 500	Unsuitable	2,869.8		

Source: Original

Map 3. Suitability of sites according to altitude based on DTM

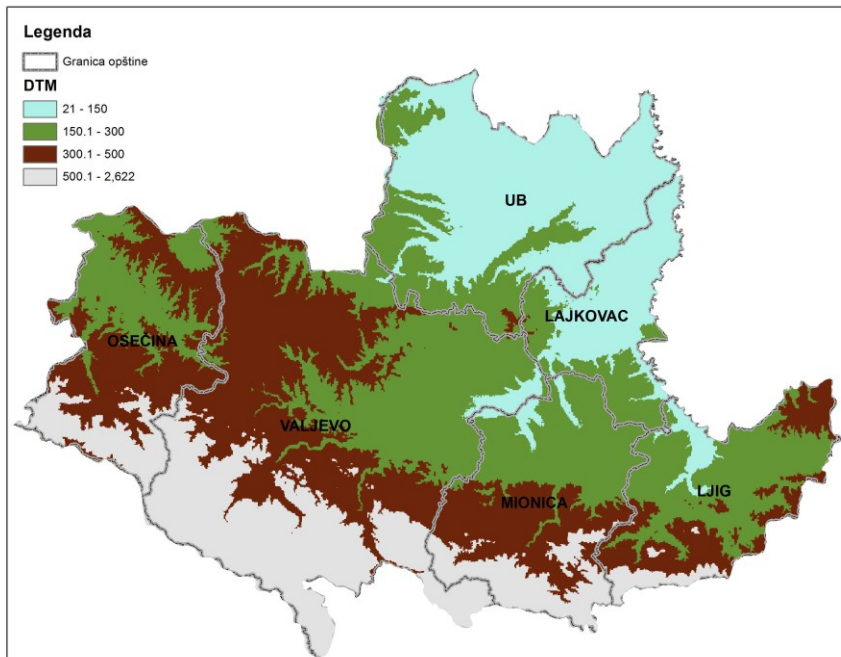

Source: Original

Water availability

Short rotation coppices have higher water requirements than agricultural crops grown in the same area. Therefore, priority should be given to ground water, surface or waste water. Although certain species are able to tolerate a higher water content in the soil, it can hinder the exploitation of coppices.

The water content in the soil is very important in establishing coppices, particularly during the initial planting of the cuttings when the roots are not yet developed. The coppices established in very dry periods often suffer great losses in the first years after the establishment. This means

that the effects of water availability on coppices must be thoroughly examined, particularly in dry areas and with species that can thrive in such conditions (Table 5, Map 5). Research studies of this type are still scarce and small-sized experimental plots do not provide sufficient basis for making general conclusions (Dimitriou and Rutz, 2015).

Map 4. Suitability of sites according to slope based on DTM

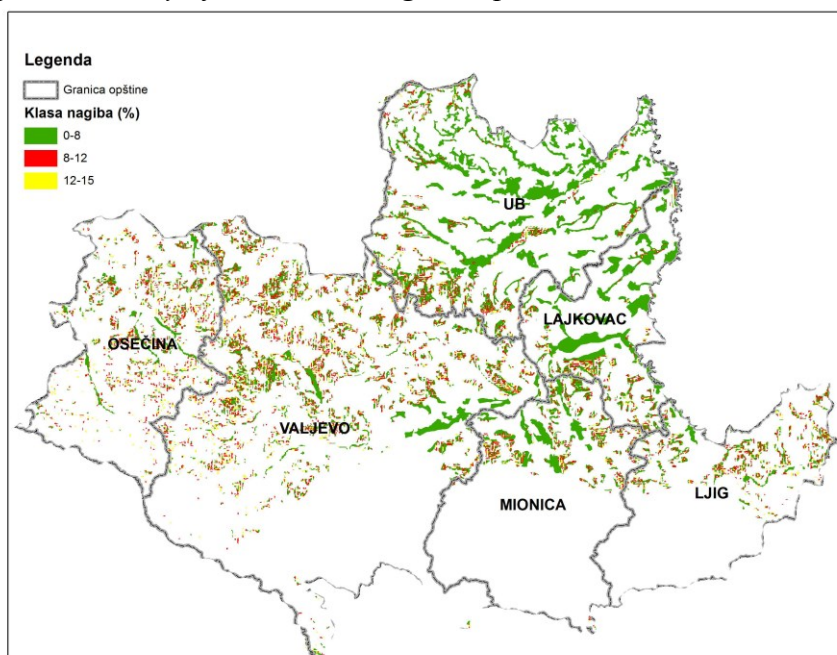

Source: Original

Short rotation coppices can have significant effects on the purification of water from agricultural areas where fertilizers and pesticides are used excessively. They increase the retention of excessive amounts of hazardous substances and with the help of transpiration reduce the pollution of surface and ground water.

Table 5. Suitability according to the distance from watercourses

Distance from watercourses	Suitability
Less than 100 meters	Very suitable to suitable
From 100 to 300 meters	Moderately suitable
More than 300 meters	Unsuitable

Source: Original

The sites with drainage systems for draining excess water are not suitable for the establishment of short rotation coppices because the roots can clog up the drainage pipes. These sites should be thoroughly examined because roots usually remain in the upper 40-50 cm of the soil.

Access to roads

Short rotation coppice plantations should have good access to road infrastructure because some operations require the use of machinery. The sites with slopes steeper than 8% are not suitable for larger plantations with automated planting and harvesting practices. Small-sized short rotation coppices, where manual planting and felling practices are applied, may be established on steeper slopes.

Map 5. Road network and watercourses

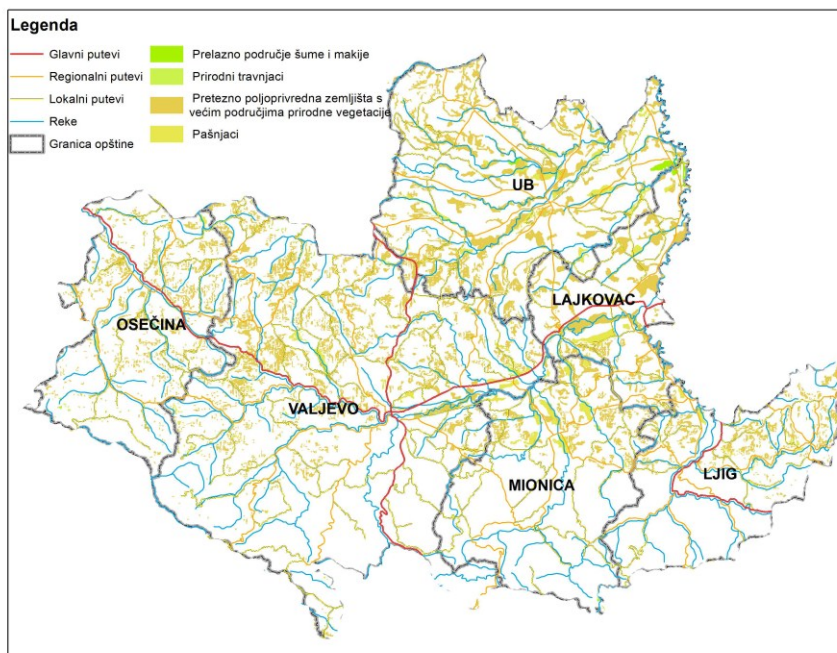

Table 6. Suitability according to the access to road infrastructure

Distance from road infrastructure	Suitability
Less than 100 meters	Very suitable to suitable
From 100 to 300 meters	Moderately suitable
More than 300 meters	Unsuitable

Source: Original

The crop is harvested in winter when the moisture content is reduced. Due to the heavy loads of the harvested wood, plantations should be close to paved (or hard unpaved) roads (Table 6, Map 5).

The size of coppice plantations

The size of a coppice plantation has a considerable impact on its management and related costs. Short rotation coppice plantations should be at least 1 to 10 hectares in size (Table 7). They can be grown on smaller sites, provided that there are several other plantations in the vicinity which allow coordinated harvest (at the same time) to reduce related costs. Small-sized coppices are acceptable in case they are established to meet individual needs for energy.

Table 7. *Suitability according to coppice size*

Coppice size	Suitability	Area (ha)
Less than 1 hectare	Unsuitable	Not studied
From 1 to 5 hectares	Moderately suitable	16244.3
From 5 to 10 hectares	Suitable	3603.3
More than 10 hectares	Very suitable	19710.6

Source: *Original*

The most preferred shape of coppices is rectangular. It is most suitable for the use of planting and harvesting machinery (especially when direct chipping is applied), but also when fencing against animals (such as rabbits and deer). However, in practice such fields are mainly used for annual agricultural crops. Therefore, short rotation coppices are usually established on irregularly-shaped fields where the cultivation of annual agricultural crops would be more expensive.

The state of the sites potentially suitable for the establishment of short rotation coppices

The structure and suitability of the Kolubara District sites for the establishment of short rotation coppices determined on the basis of the applied factors (natural condition and infrastructure requirements) are shown in Tables 8 and 9 and Map 6.

A distinction is made whether the short rotation coppices are planned to be grown on:

- agricultural land: different types of agricultural land depending on the water availability
- grassland: a distinction between intensively and extensively managed grasslands must be made
- forest: in many countries short rotation coppices are not allowed to be grown on land that is classified as forests (both from the legal aspects and due to environmental issues)

Map 6. *The structure of the productive land of the Kolubara District*

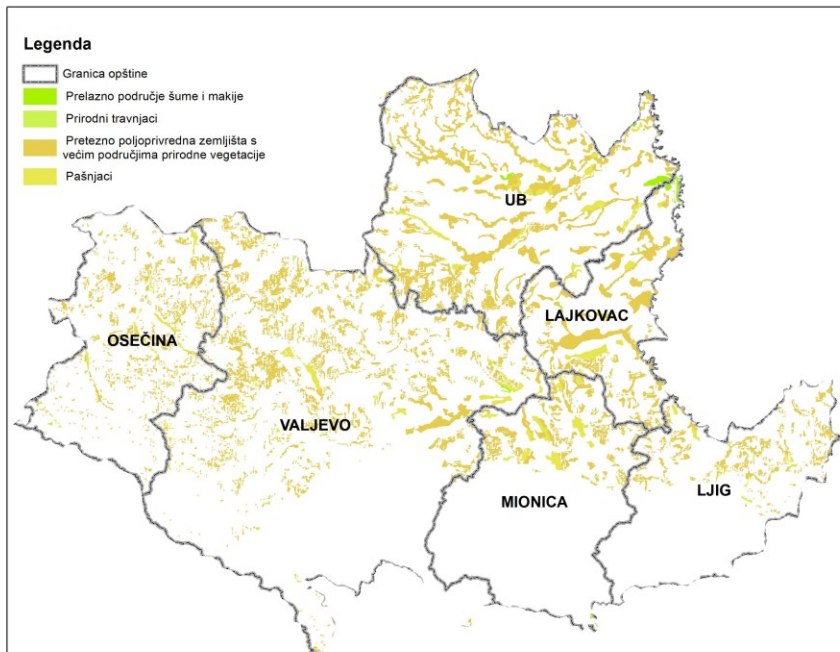

Source: *Original*

- marginal land: short rotation coppices can be established on steep slopes to prevent erosion, on flood-prone areas, under power lines, etc.
- best financial effects are achieved when establishing short rotation coppice plantations on agricultural land characterized by high fertility. In these areas they have stronger positive effects on water quality and biodiversity than agricultural crops.
- with the current prices of wood biomass and energy, short rotation coppices are less competitive compared to agricultural crops grown on fertile arable land. Therefore, they are usually established on abandoned agricultural land or grassland. However, there is a problem with the change of land use from grass to short rotation coppices since there is a

growing need to preserve grasslands. Establishment of short rotation coppice plantations on forest land would have adverse effects. Therefore it should be avoided.

Table 8. *Structure and suitability of productive land*

Category	A (ha)	Land use	Altitude	Area (ha)
Highly productive	2373.4	Grassland	Suitable	83.1
		Grassland	Moderate	7.1
		Predominantly agricultural	Unsuitable	76.8
		Predominantly agricultural	Suitable	1785.6
		Predominantly agricultural	Moderately	215.0
		Predominantly agricultural	Highly	205.8
Productive	1947.5	Grassland	Unsuitable	15.4
		Grassland	Suitable	37.2
		Grassland	Moderately	13.2
		Grassland	Highly	82.6
		Transition between forest and macchia	Unsuitable	4.9
		Transition between forest and macchia	Suitable	12.0
		Transition between forest and macchia	Moderately	3.7
		Transition between forest and macchia	Highly	21.5
		Predominantly agricultural	Unsuitable	138.5
		Predominantly agricultural	Suitable	558.60
		Predominantly agricultural	Moderately	226.1
		Predominantly agricultural	Highly	826.4
		Natural grassland	Moderately	7.40
Poorly to moderately productive	9245.3	Grassland	Suitable	637.0
		Grassland	Moderately	200.6
		Transition between forest and macchia	Unsuitable	47.9
		Transition between forest and macchia	Suitable	23.1
		Transition between forest and macchia	Moderately	11.8
		Predominantly agricultural	Unsuitable	1583.9
		Predominantly agricultural	Suitable	1414.1
		Predominantly agricultural	Moderately	3230.30
		Predominantly agricultural	Highly	480.6
		Natural grassland	Unsuitable	4.3

Source: *Original*

Table 9. *Structure and suitability of conditionally productive land*

Category	Area (ha)	Land use	Altitude	Area (ha)
Conditionally productive	16294,1	Grassland	suitable	601,5
		Grassland	moderately	57,7
		Grassland	highly	468,7
		Transition between forest and macchia	suitable	601,5
		Transition between forest and macchia	moderately	10,8
		Predominantly agricultural	suitable	601,5
		Predominantly agricultural	moderately	4788,4
		Predominantly agricultural	highly	2491,0
Conditionally productive with amelioration	9245,3	Grassland	suitable	601,5
		Grassland	highly	1142,4
		Transition between forest and macchia	suitable	601,5
		Transition between forest and macchia	highly	391,5
		Predominantly agricultural	suitable	601,5
		Predominantly agricultural	moderately	30,0
		Predominantly agricultural	highly	5948,0

Source: *Original*

‘Marginal land’, which is commonly recommended for the establishment of coppices, may include contaminated areas, areas under power lines, areas of land parallel to railway lines and landslides. In these areas, short rotation coppices are given priority over agricultural crops, except when a site of high biological diversity is in question and they can produce negative effects. The effects of short rotation coppices by type of land use are shown in Table 10.

Short rotation coppice plantations in the landscape

In order to avoid disturbances in the landscape, the following (general) principles should be followed. However, site-specific situation always needs to be addressed in detail (Dimitriou and Rutz, 2015):

- Establishment of short rotation coppices on agricultural land close to forests forms a visual effect of natural forest continuation. However, planting in the areas that contain only forests should be avoided since the landscape would become very forest-homogeneous.
- Harvesting different parts of the plantations after completing individual growth cycles gives a special kind of dynamic character to the landscape and its diversity

- Planting in the vicinity of historical and cultural sites can have negative visual impacts

Table 10. *Effects of the establishment of short rotation coppices by land use types*

Criterion	Short rotation coppices compared to		
	Agricultural land	Grassland	Forest
Use of pesticide	During establishment and removal phases similar to conventional agricultural land use; during the short rotation phase not needed.	During establishment and removal phases similar to conventional grassland; during the short rotation phase not needed.	Higher
Use of fertilizers	Considerably lower than in conventional agriculture	Considerably lower than on intensively managed grassland	Higher
Soil erosion	Considerably lower	During establishment and removal phases higher than on grassland; during the short rotation phase similar to grassland.	Slightly higher
Biodiversity	Usually much higher than in intensively used agricultural land; On extensively used agricultural land it can be higher or lower	Depends on the intensity of the grassland use as well as on species composition.	Depends on the forest type and the design of the SRC; Compared to natural forests, biodiversity in SRC is rather lower.
Climate and water	Higher evaporation, higher interception, better wind protection and temperature balancing, reduction of dust and pollutants	Higher evaporation, better wind protection and temperature balancing	Negative effects
Carbon sequestration	Considerably higher	Higher or equal; depends on management practices	CO ₂ storage considerably lower, but annual sequestration higher

Source: *Dimitriou and Rutz, 2015*

- Planting of different clones (with different size or shape and color of leaves) increases the visual diversity. Open spaces between coppices offer opportunities for recreational activities (e.g. walking)

- Short rotation coppices can be established alongside roads with heavy traffic, provided that safety is not reduced (good visibility around bends). The roads with lower traffic frequency are less affected by the establishment of coppices
- Large power plants that would use biomass from short rotation coppices are located in industrial areas, whose greenness can be enhanced by these coppices
- In predominantly agricultural areas (where annual agricultural crops are grown), short rotation coppices can increase landscape diversity.

Restrictions on the establishment of short rotation coppices

Short rotation coppices must not be established in the areas defined by NATURA 2000, on the habitats that are associated with a specific ecosystem composition or inhabited by protected plant and animal species, etc. Furthermore, short rotation coppices should not be established in the area of: intensive agricultural crops, natural beauty, national or regional significant landscapes, nature reserves, natural monuments, memorial natural monuments, immovable cultural property, recreational areas, tourist routes, viewpoints, springs, forests and woodlands and in urban areas.

Discussion and Conclusion

Firewood is one of the most important energy resources in Serbia where 50% of the population use primarily solid fuel for heating, while this percentage amounts to 90% in the poorest part of population that make the first decile of consumption (Macura, 2012). According to the study of firewood consumption in 2010, 40.9% of households in Serbia used solid fuels such as fuelwood, coal, briquettes, pellets, agricultural residues and combinations of solid and other fuels. (Glavonjić et al, 2010).

In Serbia, there are currently 57 wood pellet plants, 45 of which are operational and produce about 160,000 t of wood pellets per year. With the production capacity over 500,000 t/year, they show a trend of increasing production. Since wood pellets in Serbia are mainly produced from firewood and then exported to markets across Western Europe, it is clear that an additional source of raw material is a necessity and a priority, otherwise the sustainability of this strategic resource will be threatened.

Opting for coppices of fast-growing short rotation species in the EU countries with substantial deficiencies of wood and large areas of abandoned agricultural land requires the regulation of the ecosystem for specific economic objectives with different intensity of technical intervention and different levels of productivity.

Having designed the appropriate cartographic material and developed GIS, we determined the sites suitable for the establishment of short rotation coppices for energy purposes in the area of the Kolubara District. Site determination included the study of land use. Soil quality was defined by the type and expressed through limitations, productivity and suitability for the establishment of short rotation coppices. Altitude was determined as a limiting factor in the areas above 500 meters due to a shorter growing period.

Site determination, establishment of coppices, definition of exact regulations and procedures for the establishment and use of coppices, provision of additional raw materials for different users (power plants, wood-based panel industry, pellet plants, production of wood chips, etc.) should reduce the pressure on forests in terms of meeting the energy needs.

This kind of use of agricultural land and forests could significantly increase the utilization of the soil productive capacity, boost the income generated by public estates, local residents, local utility companies and other economy entities and entrepreneurs. It would further encourage nursery production, i.e. production of seedlings/cuttings for the stated purposes.

References

1. Dimitriou I., and Rutz D. (2015): Sustainable Short Rotation Coppice, *A Handbook*, 2015 by WIP Renewable Energies, Munich, Germany, www.srcplus.eu (20.10.2015)
2. Ducić, V., Radovanović, M. (2005): *Klima Srbije*. Zavod za udžbenike i nastavna sredstva, Beograd
3. Glavonjić B. At all. (2010): *The economic (macro-level) aspects of wood energy system in Serbia*. Rome: Based on project TCP/YUG/321,FAO.

4. Hagauer D. (2010): Telling the story in Austria – Sustainable wood energy supply, www.ec.europa.eu/energy/intelligent/projects/sites/iee-projects/files/projects/documents/whs_austria_sustainable_wood_energy_supply_en.pdf (15.10.2016)
5. IEA (1998). *International Energy Agency (IEA)*. World Energy Outlook, Edition, www.iea.org.
6. Macura A. (2012): Budućnost energetske politike Srbije, Zaključci Nacionalnog konventa o Evropskoj uniji, Lazarevac: Nacionalni konvent o EU.
7. Parikka M. (2004). *Global biomass fuel resources*. Biomass and Bioenergy 27 (2004) 613-620.
8. *Regionalni prostorni plan za područje kolubarskog i mačvanskog upravnog okruga*, www.rapp.gov.rs/Storage/Global/Documents/2015/
9. KolubarskiMacvanski/Plan-usvojen.pdf (10.10.2015)
10. U.S.Energy, I. (2012): The *International Energy Outlook 2011 (IEO2011)*. Washington: U.S. Energy Information Administration.

ANALYSIS OF CONDITIONS AND RESULTS OF THE RASPBERRY PRODUCTION IN ARILJE RASPBERRY-MOUNT¹

Nataša Kljajić²

Abstract

Raspberry is the most important species of berry fruits, which achieves extremely high yields in the favourable agro-ecological conditions, along with the application of modern and adjusted agro-technique. It cultivates easily and simple; the production risk is significantly lower than regarding big fruits; it employs sufficient labour, especially regarding picking, while the financial resources invested in its products can be soon returned. In conditions of the current climate changes, the application of irrigation, limited to smaller areas in a private property on the territory of Arilje raspberry-mount, has provided the results in form of high and uniform yields of high-quality fruits, which can be easily sold on the market. In this manuscript conditions and results in the production of raspberry in Arilje-mount were first of all analysed, and then some of measures for the improvement of raspberry production were suggested, and finally there was made a recommendation for the introduction of renewable energy sources in the production. These positive experiences should be expanded to the territory of entire Serbia, by which can be affected to the improvement of situation in agriculture, as well as the entire economic situation.

Key words: *raspberry, climate, irrigation, production, renewable energy sources.*

Introduction

Fruit growing is one of the most profitable branches of agriculture. The natural conditions of Serbia, climate and land, are extremely favourable for fruit growing, and the advantage of our fruit growing reflects in the spatial and biological diversity and tradition in fruit growing. No

¹ This paper work is result of the project III – 46006 Sustainable agriculture and rural development in terms of the Republic of Serbia strategic goals realization within the Danube Region, finance by Ministry of Education, Science and Technological Development of the Republic of Serbia.

² Nataša Kljajić Ph.D. Research Associate, Institute of Agricultural Economics, Belgrade, Volgina street 15, 11060 Belgrade, e-mail: natasa_k@iep.bg.ac.rs

agricultural branch can bring that kind of profit like fruit growing, especially in hilly-mountain areas. On the other hand, there was made a great turning point in the new technologies introduction and the change of variety assortment structure, and this could be thanked to science, profession and manufacturers who were willing and ready to accept new, modern production technologies.

Orchards in the Republic of Serbia, with a total area of 163.310 ha in a total used agricultural land have the share of 4.7%, i.e. they make 6.2% of arable land (*Statistical Yearbook of the Republic of Serbia, 2015*). The greatest importance for our country's economy, within fruit production, has the production of berries (strawberry, raspberry, blackberry, blueberry, cranberry, currant and gooseberry), because there realizes around 250 million € of income from their export (<http://www.novosti.rs/vesti/naslovna/ekonomija/aktuelno.239.html:578520-Srbija-na-prvom-mestu-u-svetu-po-proizvodnji-malina>) and within berries, it is raspberry.

Raspberry (*Rubus idaeus L.*) is the most important species of berries. Raspberry fruits are attractive, very tasty, of extraordinary aroma, succulent, with great nutritive, dietary and technological value and this is why raspberry is very appreciated and saleable fruit, manifesting significant advantages in regard to other fruit species. It reproduces easily and starts to bear in the first or second year after planting, while it reaches full ripening in the third year. In favourable agro-ecological conditions, with the application of modern agrotechnics, raspberry achieves high yields. It returns the investments quickly and contributes to better utilisation of land in hilly-mountain areas. The investments in plantations are relatively high, but the invested funds return quickly. It grows easily and simple, the production risk is significantly lower than regarding big fruits; it employs a lot of manpower, especially when harvesting.

In recent years, raspberry has become the most significant Serbian export product, while Serbia has become famous in Europe by raspberries as the national products, which has persevered the competition on a choosy west market. Over 90% of produced raspberry is frozen and exported, while the rest is sold as a fresh or processed in other products. Around 25% of the world production of raspberry comes from Serbia. It exports by an average price of 1,4-1,5 €, mostly frozen. If raspberry would export as fresh, in a „map“ package, raspberry could sell even 2-3 times more expensive. Small quantities export as fresh and as concentrates. Fresh

raspberry is avoided to be exported as fresh, because it is highly perishable. In past years, the most attractive export products are frozen raspberry in the form of roland, semolina and block (Kljajić N., 2014).

Besides numerous positive characteristics, some of the raspberry weaknesses are: high sensitivity of fruits, weak permanence, poor transportability, gathering of fruits is done along with a high participation of manpower, etc.

Specific economic significance of raspberry is determined by the following factors: high and diverse use value of a fruit; relatively high rate of return in favourable agro-ecological conditions; high merchantability of a product; additional employment of manpower and indirect impact to an overall social-economic development; raspberry as a honey plant, etc. (Petrović and Milošević, 2002).

In past years, the production and yields of raspberry per area unit in Serbia vary significantly due to the direct and indirect influential factors, such as: - inappropriate land for plantations; - poor health and quality of planting material; – inadequate application of agro and pomo-technical measures, etc.

Among the mentioned factors, climate has also increasing and more expressed impact to the height of yields, and it manifests through frequent and longer droughts, caused by the increase in air temperature and the decrease in precipitations, resulting a need for irrigation in the process of raspberry production.

Seasonal change of the climatic parameters in past years has become a limiting parameter for intensifying agricultural production and especially the disposition and amounts of precipitations during the vegetative period. The only long-term form of the fight against drought is the introduction of irrigation in agricultural practice, as the regular and mandatory measures. The application of irrigation, limited to smaller areas in private ownership on Arilje raspberry-mount area, has given the results in form of high and uniform yields of high quality fruits, which are easy to sell on the market. These positive experiences should expand to the territory of entire Serbia, by which could affect to the improvement of situation in agriculture, as well as to the entire economic situation (Kljajić N., et al, 2013).

The production of raspberry in the Republic of Serbia

The production of raspberry worldwide is realised on relatively small areas regardless that there is much more space for its cultivation (Kljajić N., et al, 2013).

In an analysed period of raspberry production in the world (2006-2014), described in the graph 1, we can see that Serbia is among leading manufacturers. It takes a third place, right after the Russian Federation and Poland.

Graph. 1. Average production of raspberry in the world in time period 2006-2014

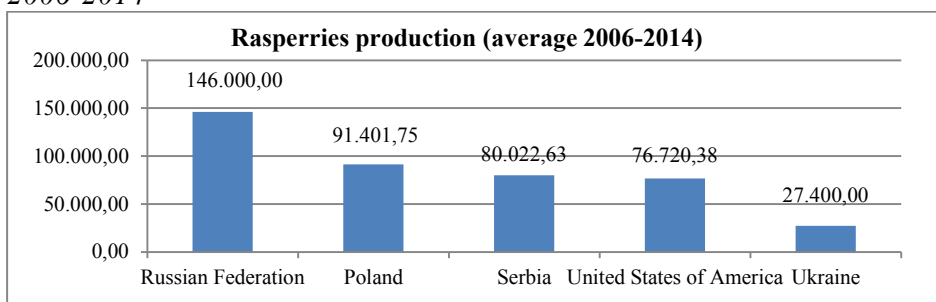

Source: <http://faostat3.fao.org/browse/Q/QC/E>

The production of raspberry in the Republic of Serbia in the period 2006-2016 was shown in *Table 1*. An average area under raspberry-yards for the studied period amounts 13,579 ha, and average yield is 76,807 t, or in average 5.7 t/ha of manufactured raspberry.

Table 1. The production of raspberry in the Republic of Serbia in time period 2006-2016

Year of research	Republic of Serbia		
	Areas under raspberry plantations (ha)	Total yield (t)	Yield (t/ha)
2006	15,024	79,680	5.3
2007	14,496	76,991	5.3
2008	14,680	84,299	5.7
2009	14,957	86,961	5.8
2010	15,174	83,870	5.5
2011	15,354	89,602	5.8
2012	11,996	70,320	5.9
2013	12,024	68,458	5.7
2014	11,040	61,715	5.6
2015	11,041	66,176	6.0
Average	13,578.6	76,807.2	5.7

Source: Statistical Office of the Republic of Serbia, *Statistical Yearbook of RS, 2007-2016*

Raspberries export as frozen or as manufactured products for concentrates and juices. In the year 2015 Serbia was earned 260 million USD from raspberry, which had put it in position of the greatest raspberry exporter into the European Union. The members of the Serbian Business Association of Cold Storages realize from 60% to 70% of domestic export of raspberry, and almost all cold storages – the members of the association have HACCP standards and all other standards which the world market has required (<https://adavinic.wordpress.com/2016/04/26/poslovno-udruzenje-hladnjaca-srbije-i-svetska-organizacija-iro-organizuju-svetski-susret-malinara/>).

The largest amount of frozen raspberry was exporting in Germany, then in France, Belgium, USA, Sweden, Great Britain, the Netherlands in 2012, 2013 and 2014 (*Table 2*).

Table 2. *Export of raspberry by countries in time period 2012-2014*

	Quantity, t			Value, thousand USD		
	2012	2013	2014	2012	2013	2014
Raspberry frozen, sugarless	64,417	61,417	73,253	135,648	187,358	236,518
Germany	24,296	22,447	24,122	50,500	68,579	78,930
France	16,404	16,215	17,058	32,256	43,781	51,276
Belgium	7,199	7,087	7,276	16,872	24,412	25,045
USA	1,260	1,304	3,554	3,138	4,938	12,733
Sweden	1,954	2,680	3,420	5,776	9,122	12,280
Great Britain	2,386	1,734	2,296	4,840	5,924	7,124
The Netherlands	1,429	1,019	2,172	3,087	2,871	6,877
Other countries	9,340	8,931	13,355	19,179	27,731	42,253

Source: *Statistical Office of the Republic of Serbia, 2015*

The area of Arilje raspberry-mount, with its production centre Arilje, belongs to Zlatibor District, and it is located between the river basins of the rivers Moravica, Veliki Rzav and Mali Rzav. Agriculture dominates in the structure of municipal national income (with 41%) thanks to, first of all, favourable natural conditions for its development, as well as the acquired tradition in production.

Thanks to the production of raspberry and simultaneously synchronized development of other economic branches, this initially economically underdeveloped area has become highly-developed for our conditions, with numerous local cold storages. Foreign exchange assets gained by the export of raspberry, used for the import of the latest equipment for Arilje production, were indirectly allocated to necessary working capital for the primary production needs and the processing of raspberry, along with very important provided support of factory workforce in the production of raspberry in the harvest „tips“ through the collective vacations (which can serve as example to other municipalities).

Areas under raspberry in Arilje municipality are 1,226.05 ha (census of agriculture, the year 2012), in which there manufacture annually in average 15,000 t (13,500-16,500 t). Around 20,000 t of raspberry fruits are frozen, processed and exported in cold storages from the municipal territory. Raspberry grows in the whole municipal territory in over 95% in family holdings, on average plots of around 0.3 ha. As a working intensive crop, it has a great influence on additional employment (<http://arilje.org.rs/privreda/poljoprivreda.html/09.11.2016./>).

The production of raspberry in Arilje makes 19.5% of total raspberry production in the Republic of Serbia (areas under raspberry in the Zlatibor District are 3,893 ha, and in the region of Sumadija and West Serbia 10,513 ha, also according to data of Census of Agriculture, 2012).

The yields of raspberry vary from year to year depending on variety, health condition and age of plantation, ecological conditions and agro-technique, which is normal regarding that the high utilization of the raspberry genetic potential can be achieved only if all production factors are in the harmonious-optimal relationship.

Therefore, despite of a high technology of the raspberry espalier cultivation and a genotype of well selected variety (Willamette), the yields of fresh fruits in Arilje-mount vary in the range from 7.5 to 11.8 t/ha in conditions of natural water regime, i.e. without irrigation, although its genetic potential reaches even 52 tons per hectare (Milivojević J., and associates, 2005).

Drought, which is present almost every year with longer or shorter duration, jeopardizes seriously the production of raspberry, especially in „the critical period“ (phenophase from the raspberry flowering phase to picking season in

June and July), when raspberry needs water the most. Irrigation then becomes not only inevitable, but also its use becomes more effective.

On sloping terrain of Arilje-mount, on which most of the existing raspberry-yards are located, after all as in the whole Serbia, raspberry mostly can irrigate by local soil wetting using drop irrigation. Such irrigation system is considered as the most perfect technical-technological solution in the cultivation of raspberry in terms of irrigation.

The climatic water balance during the raspberry vegetative period in Arilje-mount was determined in this manuscript according to climatic specificities, which were analysed through the mean monthly values of climate parameters for the period from 2006 to 2015. Data refer to the weather station „Pozega“.

Thereby, evapotranspiration is determined by a FAO *Penman-Monteith* method, by the following relation:

$$ET_o = \frac{0.408 \cdot \Delta \cdot (R_n - G) + \gamma \cdot \frac{900}{T + 273} \cdot u_2 \cdot (e_s - e_a)}{\Delta + \gamma \cdot (1 + 0.34 \cdot u_2)}$$

ET_o–reference evaporation (mm/day); **R_n**–net radiation on crops canopy (MJ/m²xday); **G**–energy consumed for soil heating (MJ/m²xday); **T**–the mean monthly air temperature on 2 meters of height (°C); **u₂**–wind speed measured on 2 meters of height (m/s); **e_s**–saturated steam tension (kPa); **e_a**–real steam tension (kPa); **e_s–e_a**–deficit of steam tension (kPa); **Δ**–curve inclination of steam tension (kPa/°C); **γ**–psychrometric constant (kPa/°C).

The amount of effective precipitations during the productive part of vegetative period of raspberry (April-September), which refers to a part of total precipitations which raspberry uses effectively through its root system, is determined by FAO method (*FAO Bullten d'irrigation et de drainage (1984): Precipitation efficace. Rome. p.p. 1-40*).

Rapberry yields in terms of the natural water regime, i.e. without irrigation, were taken over from the Republic Statistical Office, while in terms of irrigation, from the experimental fields located in Arilje raspberry-mount, on which the research was conducted under the auspices of the Ministry of Education, Science and Technological Development of the Republic of Serbia.

Research results

Necessary amounts of water for the successful cultivation of raspberry are variable, not only from year to year, but also during the same growing season.

They depend on the series of factors in the soil-plant-atmosphere system, which could be thoroughly studied in the determination of the irrigation order. In the first instance, they depend on the climatic-meteorological features of an area in which grows raspberry; on climatic conditions; and finally on the raspberry biological features.

It means that raspberry needs for water are of local character and depend on a complex impact of the environmental conditions and biological features of a plant (Sredojević Z. et al., 2013). Therefore the determination of an optimal irrigation order of areas under raspberry, which means the frequency norms and watering by the specific periods of time, is a very complex process and requires a multi-year study.

Two basic numerous climate characteristics, by which express the impact of energy and aero-dynamic condition of atmosphere ground layer to the amount of energy which land under the raspberry plantations receive and indulge in the atmosphere to the amount of water that enters from the atmosphere into the soil and evaporates from soil to atmosphere, are: - reference potential evapotranspiration E_{To} (mm/day); i –effective precipitations P_e (mm).

Reference potential evapotranspiration expresses the energy and aero-dynamic condition of atmosphere ground layer, which poses a law that a certain amount of water delivers from land surface by evaporation and transpiration through herbal cover stoma (raspberry), which would saturate the air to a maximum possible level in a form of aqueous vapour.

Hypothetically, it is equal to evaporation from land, covered by thick grass in full rise, of uniform height 0.12 meters, fixed surface resistance of 70 s/m and albedo of 0.23. The fixed surface resistance essentially means a medium dry soil surface watered by a weekly watering number (Allen et al. 1998), which volume is shown in Table 4.

Table 3. Climate parameters in Arilje raspberry-mount (2006-2015)

Months	Years of research									
	2006	2007	2008	2009	2010	2011	2012	2013	2014	2015
<i>Maximum monthly air temperatures (Tmax. °C)</i>										
April	17.7	20.2	17.9	19.9	17.7	18.2	18.7	20.1	17.0	17.5
May	22.5	23.3	23.2	24.5	22.1	21.6	21.4	23.4	20.8	23.4
June	24.8	27.8	26.8	25.2	25.2	26.0	29.2	24.9	25.0	25.4
July	27.8	31.4	27.8	28.2	27.9	28.2	31.6	28.5	27.2	30.9
August	25.7	29.7	28.9	27.9	28.1	30.2	32.3	30.0	27.1	30.7
September	23.0	20.4	20.8	24.5	22.2	27.8	27.6	22.5	21.1	24.8
<i>Minimum monthly air temperatures (Tmin. °C)</i>										
April	5.9	2.0	5.4	4.4	5.1	4.0	3.5	4.3	5.7	2.7
May	8.5	10.8	8.8	9.6	9.1	9.1	8.2	9.6	9.0	10.0
June	12.5	14.1	14.2	12.8	13.7	12.4	12.8	13.2	12.4	12.1
July	14.0	12.6	13.7	14.3	15.2	13.9	14.6	12.9	15.1	14.5
August	13.5	14.3	12.8	14.5	14.8	12.8	11.5	13.5	15.1	14.4
September	11.1	8.4	8.9	10.6	10.1	10.7	9.5	8.5	12.5	12.0
<i>Mean monthly air temperatures (Tsr. °C)</i>										
April	11.3	10.9	11.0	11.8	11.0	10.6	10.7	12.0	10.6	10.0
May	14.7	16.6	15.4	16.7	15.1	14.3	14.5	16.0	14.1	16.5
June	18.2	20.2	19.7	18.4	19.2	19.1	21.1	18.5	18.1	18.3
July	20.1	21.6	20.3	20.6	21.0	20.6	22.9	20.3	20.2	22.4
August	18.7	21.1	20.0	20.3	20.6	20.7	21.4	21.0	19.7	21.6
September	15.9	13.1	13.9	16.2	15.1	17.8	17.5	14.4	15.5	17.6
<i>Monthly sun exposure values (n. h)</i>										
April	115.5	264.4	114.3	176.2	137.9	178.0	160.7	207.9	100.7	192.7
May	202.8	193.6	211.7	210.1	155.9	186.3	183.0	199.9	171.2	191.8
June	184.6	232.0	216.5	198.1	182.0	248.2	315.6	203.1	220.5	245.8
July	232.2	346.7	235.4	272.7	235.4	269.2	302.1	309.9	240.8	313.2
August	185.5	235.1	281.3	220.2	240.7	293.3	333.3	270.1	221.7	252.0
September	155.7	137.5	141.3	168.2	141.3	232.7	221.0	171.2	91.0	165.7
<i>Mean monthly values of relative air humidity (RH. %)</i>										
April	76	70	77	74	80	73	76	72	83	70
May	75	79	78	75	80	81	80	76	81	75
June	77	77	79	78	82	74	71	78	80	78
July	78	67	76	77	81	75	69	73	80	71
August	81	74	74	80	80	72	62	70	82	74
September	84	83	80	81	82	75	70	80	90	78
<i>Mean monthly values of wind speed measured 2m above land surface (V.m/s)</i>										
April	0.7	0.6	0.7	0.7	0.9	1.3	1.2	1.0	0.9	1.3
May	0.9	0.6	0.4	0.6	1.0	1.0	1.0	1.1	1.2	1.0
Jun	0.4	0.6	0.4	0.6	0.8	1.2	1.1	1.0	1.0	1.1
July	0.4	0.7	0.6	0.5	0.5	1.0	1.0	1.0	1.0	1.0
August	0.5	0.6	0.5	0.3	0.5	0.8	0.9	1.1	1.0	1.0
September	0.4	0.3	0.4	0.2	0.5	0.9	1.0	0.9	0.8	0.9
<i>Monthly sums of total precipitations (Puk. mm) (Puk=Pe)</i>										
April	73.9	22.2	52.2	22.5	58.8	28.7	64.9	28.5	169.1	52.1
May	49.3	98.6	96.6	25.3	66.5	88.6	106.8	100.9	188.7	49.8
June	134.6	46.3	54.4	169.4	99.7	33.9	50.3	91.4	109.5	83.4
July	107.7	37.3	72.2	70.1	83.5	71.0	52.3	21.6	103.4	11.1
August	120.5	41.9	11.6	61.9	38.5	8.1	1.8	36.2	98.6	41.5
September	39.9	110.1	77.6	17.5	48.3	43.4	10.7	71.6	169.1	66.2
Sum=Pe	525.9	356.4	364.6	366.7	395.3	273.7	286.8	350.2	838.4	304.1

Source: Meteorological yearbooks. 2006-2015. Republic Hydrometeorological Service.

Table 4. *Mid vegetation values of evapotranspiration in Arilje raspberry-mount (2006-2015)*

Months	Years									
	2006	2007	2008	2009	2010	2011	2012	2013	2014	2015
April	2.01	2.44	2.27	2.15	2.24	2.41	2.32	2.52	1.77	2.48
May	2.87	2.57	2.72	2.85	2.50	2.99	2.99	3.29	2.92	3.14
June	3.08	3.54	3.29	3.34	3.10	4.09	4.73	3.67	3.69	4.00
July	3.52	4.62	3.78	3.81	3.60	4.27	4.83	4.54	3.94	4.74
August	3.09	3.49	3.61	3.22	3.43	4.07	4.63	4.13	3.48	4.04
Sept.	2.29	2.55	2.47	2.43	2.46	3.05	3.13	2.53	1.95	2.61
Total	515.3	586.9	554.3	543.9	529.4	651.3	691.3	632.4	542.8	642.2

The vegetation evapotranspiration sum in Arilje raspberry-mount ranges from 515 to 691 mm and varies from 1.77 mm/day (minimum) to 4.83 mm/day (maximum). Its highest values are in June and July, when there is instantaneous the highest water deficit in soil and the greatest demand of raspberry for water.

The effective precipitations are part of total precipitations used by raspberry, and for this paper's needs, by the effective precipitations (*Table 1, Graph 2*) are considered all precipitations that fell on land surface, regardless to their daily sums amounts, because in order small amounts of rain to fall, it is necessary to get cloudy, by which reduces insolation and also air temperature. The relative air humidity reduces by passing raindrops through the atmosphere and by their evaporation, and all that leads to the reduction of total water amount needed for irrigation (*Milivojević, 1984*). Their total sums in raspberry vegetation period range from 273.7-838.4 mm. and they are lesser (in most of years of the research) in regard to a total water inflow from rain (*Table 1*) for 25.33 to 58.52 %. The biggest difference was in 2012, which was known as extremely dry year, while the years 2010, 2006 and 2014, characteristic by the increased precipitations (2014, floods) were not taken into consideration because precipitations were surpassing evapotranspiration. It is clear that in the productive part (vegetation period) of raspberry (April-September), precipitations do not provide raspberry with sufficient amount of water, by comparing the inflow of water by the effective precipitation (P_e . mm) and the outflow of water by evapotranspiration (E_{To} . mm/day) (*Graph 2*).

Graph. 2. Histogram of climati–water deficit in Arilje raspberry-mount (2006-2015)

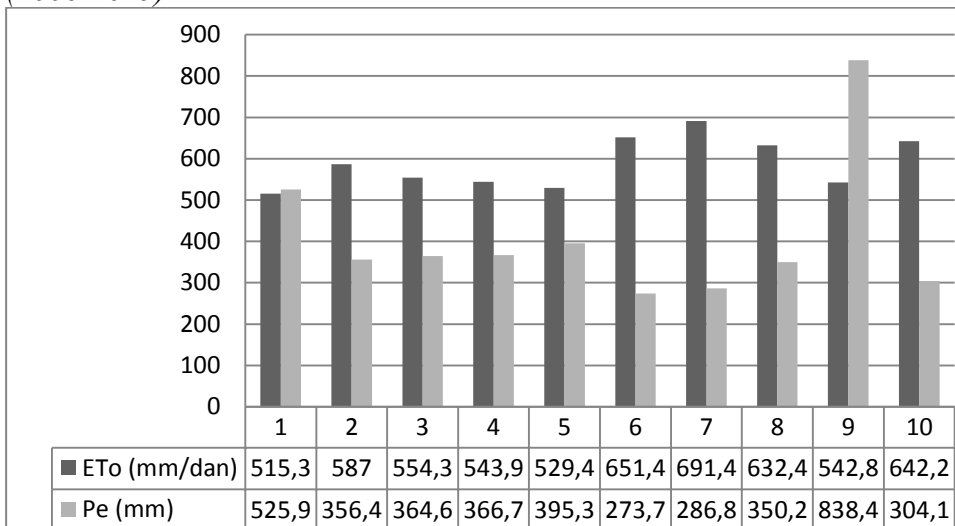

It means that high yields of raspberry, water deficit of 134.13-404.55 mm, should be covered by irrigation. Natural water regime of land is corrected by this intervention and leads over from the group of natural into the group of anthropogenic water regimes of an irrigation type, to which raspberry reacts by significant increase in yields, as it was determined in multi-year experiments conducted in Arilje raspberry-mount.

The use of irrigation in the raspberry cultivation systems is of great importance, while there provides easily-accessible water (which misses during the growing season in case of reduced precipitations) by its use. The use of irrigation is caused by many factors, as the climatic, land and orographic conditions, the needs of raspberry for water by the specific phenophases of its vegetative cycle, the possibility to supply a large amount of water of adequate quality, etc.

The drop irrigation systems use intensively in raspberry-yards in past years, and they have the negligible water losses compared to the maximum effects achieved by its use (Gajić B. et al, 2013). Water disposes in drops under small pressure and moistens soil nearby every plant, slowly, only several litres per hour (1, 2, 3 l/h) through droppers, disposed on pipes laterally (laterals). It is done until the optimal soil moisture in an active rhizosphere layer is not provided.

Soil features. On the territory of Arilje municipality can be found diverse types and sub-types of soils, extremely heterogeneous by their many characteristics (rootstock plantation, age, the depth of the active rhizosphere layer, mechanic and chemical characteristics, water and air regulations, etc.), which has the controlling influence on the ways of their use. First four classes soils participate in total areas with 3,369 ha, i.e. only 16.74%.

All soils on this territory can be divided in four large groups:

- *Soil of river valley, dry river and lake terraces and basins* – they occupy around 10% of agricultural areas and have a great importance for agricultural production due to favourable configuration, deep and fertile arable layer and the possibility to irrigate,
- *Newly-created soils in the first zone of the delluvial water accumulation* – they occupy around 70% of areas. Those are mostly underdeveloped land with different production capacity. Besides dominating meadows, pastures and forests, these soils are favourable for the cultivation of raspberries but also other berries, then plums, apples and some other types of vegetables (potato and others),
- *Skeletal soils above and below the first zone of delluvial water accumulation* – they were created mainly below degraded forests and pastures by erosion. They occupy around 15% of areas and mainly are in hilly-mountain zones,
- *Upland dark fertile soil on limestone substratum in the grass vegetation zone, on the mountainous highlands* – they occupy less than 5% of areas and are located in south-west part of the municipality. They have different production capacity and use for growing potato, or as pastures, meadows and bushes (Kljajić, 2012).

Hydrographic features. On the territory of Arilje municipality there are three major watercourses. These are the rivers Moravica, Veliki Rzav and Mali Rzav and more secondary watercourses and numerous springs. Thus, this area is rich with water potential and it has extremely favourable conditions for irrigation (Kljajić N., 2012).

Measures and recommendations for the improvement of raspberry production

Some of the measures, practical for the improvement of fruit growing and raspberry growing in Serbia, are:

1. Optimum plant density, specific for every combination of varieties/rootstocks aiming to increase productivity per area unit,
2. Setting up the anti-hail networks which, in addition to the protection of hail, also prevent the phenomenon of fruit scorches from high temperatures,
3. Selection of good assortment structure,
4. Biological control of fertility should be a base, not only for the determination of pruning intensity, but also for planning yields, packaging and protection agents,
5. Fruit nutrition must be adjusted to the Integral production concept requirements. The program of fruit trees fertilization must be based on the results of a land and foliar analysis, the needs of varieties, characteristics of the land maintain system, fruit growing system and a planned yield,
6. Indispensable use of irrigation without which there is no modern intensive production of fruits,
7. Introduction of new technologies of storing and packaging fruits and modern mechanization in fruit growing,
8. Association of manufacturers and creating a brand.

It is necessary to accept it in the harsh market conditions of the modern production technology, and especially the quality standards (GlobalGAP, Integral production) (<http://www.ains.rs/predavanja/AINS-VOCARSTVO%20SANSa%20POLJOPRIVREDE.htm>).

Raspberry, among other features, has also the epithet of ecological, i.e. „heathy safe food“, and therefore export could increase, along with the adequate marketing measures, because there is significant and stable export demand.

In terms when it is necessary to provide a favourable environment for faster economic and agricultural recovery, it is inevitable to elaborate a developmental concept of further improvement of fruit production. It is necessary to elaborate developmental programs on the stable marketing basics in accordance to available ecological conditions and the requirements of a modern domestic and foreign market (<http://www.novosti.rs/vesti/naslovna/ekonomija/aktuelno.239.html:601982-Malinjaci-najvece-fabrike-u-Srbiji>).

Use of the renewable energy sources in the process of production.

Renewable energy sources

When we talk about the climatic changes today, we think first of all on floods, extreme drought, wild-fires, peneplain, etc. since the beginning of the 20th Century, which have occurred as a result of an anthropogenic influence. All these phenomena are the results of global warming, which have occurred owing to the increased greenhouse effects.

The effects, or to say the consequences of global warming are multiple: more frequent and longer draughts, frequent floods, more frequent occurrences of severe hurricanes and storms, reduced amount of available fresh water, large disturbances in different eco-systems due to their “displacement” to north, when some species will be exterminated, infectious diseases will spread to north (for example, malaria), disturbances in food chains, disturbances in life cycles and phenophases, so we can expect that some plants bloom earlier than their pollinators appear, etc.

The most important mechanisms for the fight against climate changes and somehow the mainstay of energy independence in the future are the renewable energy sources regarding that they reduce dependence from unreliable and unstable fossil fuels markets, especially oil and gas.

Renewable energy sources (RES) comprise sun energy, water energy (hydro energy), air energy, geo-thermal energy, solid biomass, biogas, biodiesel and bio-ethanol. Unlike the non-renewable energy sources which have occurred in the tens of millions of years long process and which exhaust pretty fast (reserves are estimated to tens and hundreds of years), the renewable energy sources have constantly cyclically renewed, and they have been consumed at a rate that is less than the speed of their creation in nature (Kljajić N. et al, 2016).

Agriculture is a significant consumer of fossil fuels, which exploitation degrades land and water, while combustion releases gases with the greenhouse effect. The prices of agricultural products are highly dependent and sensitive on the fuel prices trends. For these reasons, using energy from the renewable sources becomes a very important issue for the future of the world food production. The use of energy from the renewable energy sources requires minimum engagement of limited land and water resources and they don't distort their ecological status.

The Republic of Serbia disposes with the renewable energy sources of sun, water, wind energy, as well as geothermal and biomass energy.

Some of the implemented researches in our country have determined the possibilities of efficient substitution of fossil fuels by electrical energy from renewable sources, mostly from sun and wind energy, in numerous activities which realize in the modern, multifunctional agriculture: for starting the pumps for irrigation, drying cereals, oleaginous plants and fruits in silo and driers, in the production of artificial fertilizers and pesticides, in greenhouse production and fishery and especially in organic production, pasture cattle breeding and agro-eco and eco-organic tourism, in holdings in areas with a high natural value and underdeveloped energy infrastructure, where the *solar systems* has an advantage.

However, this technology for some time requires subsidies to be widely adopted by farmers. Preconditions of this type of investments in agricultural sector, besides the financial resources, informing and the education of users, are the activities which usually aren't available to dominantly represented small and medium holdings, especially to those in remote areas, so the agricultural advisory services and the association of farmers and water users play an important role in this area.

Nowadays, the motor pumps and aggregates on petrol and diesel drive mainly use for the needs of irrigation in agriculture in family agricultural holdings in the Republic of Serbia.

For the purposes in agriculture use mostly the *stationary photovoltaic solar systems*, which are set on well sunny locations and nearby an agricultural area, i.e. gardens, arable plots and greenhouses/plastic foil houses, etc.

Windmills can also be used for irrigation, but mainly in Banat and areas with the air flow throughout the year.

As for the stationary photo-voltaic solar systems, they have shown as very efficient for irrigation, but also have a serious flaw that they can be used only in places where they are set and cannot be moved to other locations. In the Republic of Serbia, the family agricultural holdings (the highest percentage) have arable land mostly distributed, sometimes even several kilometres away one from another. In this respect, the stationary solar systems are not the economical solutions for this category of agricultural manufacturers, since they don't satisfy their needs completely in all locations. From this reason,

the agricultural manufacturers prefer to opt for purchasing the motor aggregates for irrigation than to invest in the solar systems for irrigation.

The solution for the above mentioned problem could be so called portable (mobile) solar systems for the production of energy. They have the advantage in a fact that they can be relatively easily and quickly moved from place to place without any special preparatory activities in the field. In that sense, these devices provide much more freedom and flexibility for their use in agriculture (*techno-economic aspects of the renewable energy sources use and the use of mobile robotize d solar electro-generators in agriculture. The study, Project of the Ministry of Agriculture and the Environment Protection of the Republic of Serbia, Institute of Agricultural Economics, 2015*) and they are good for a recommendation to use also for the raspberry irrigation.

Incentives of the Republic of Serbia for agricultural production

Registered agricultural holdings which are engaged in plant production can count on various incentives by the state. Accordingly, for the fruit growing sector and raspberry growing as well, in the year 2016 were planned the following incentives and were analysed according to the program activities³:

1. *Direct payments* which comprise:
 - a) Basic incentives for plant production in amount of 2,000 RSD/ha,
 - b) Recourses for fertilizers in amount of 2,000 RSD/ha,
 - c) Recourse for the storage costs in public warehouses in amount of 40% of the storage costs;
2. *Measures of rural development*⁴:
 - a) Stimulating new perennial plantations of fruit trees, grapevine and hop in amount of 150,000.000 RSD,
 - b) Support for the improvement of primary agricultural production in amount of 514,100.000 RSD,
 - c) Purchasing equipment in the dairy sector, the sectors of fruits,

³ Decree on incentives distribution in agriculture and rural development in the year 2016, Official Gazette of RS, no. 8/16

⁴ Recourses for the insurance premium for crops, fruits, perennial crops, nursery beds and animals reimburse in maximum amounts of 40% of paid insurance premium, i.e. in maximum amount of 45% of the paid insurance premium in areas with difficult working conditions in agriculture. For other analysed measures of rural development the incentives are paid in maximum amount of 40% of value, i.e. in maximum amount of 55% of a value in areas with difficult working conditions in agriculture.

- vegetables and grape in amount of 90,000.000 RSD,
- d) Recourses for the insurance premium for crops, fruits, perennial plantations, nursery beds and animals in amount of 450,000.000 RSD,
 - e) Incentives for organic production in amount of 92,000.000 RSD,
 - f) Incentives for the preservation of plant genetic resources in amount of 5,000.000 RSD;
3. *Credit support to fruit production*⁵ – Loan fund which are granted to the registered agricultural holdings, entrepreneurs and legal entities which are engaged in fruit production. The state role reflects in subsidizing a part of interest which is charged on the loan. The loan repayment period is 1-3 years with a grace period of 1 year, interest rate is 6%, and the loan is granted and paid in RSD. Agricultural manufacturers which are engaged in fruit production can use a granted amount of loan if they purchase: planting material, all types of mineral fertilizers and plant protection agents;
 4. *Special incentives*, and first of all the incentives for the production of planting material and certification and clonal selection in amount of 22,650.000 RSD;
 5. *Support program to the private sector for fruits and berries in south Serbia* plans the total financial resources in amount of 110,001.000 RSD, of which 66,000.000 RSD of budgetary funds and 44,001.000 RSD of the government of the Kingdom of Denmark donations for the program implementation.

The mentioned incentives are paid from the budget of Ministry of Agriculture and the Environmental Protection through the Directorate for Agrarian Payments. The exception is resources meant for the credit support which pays off through the Fund for Stimulation of Agricultural Production Development in the Republic of Serbia.

Conclusion

Nature endowed the Arilje area with fertile land, clear mountain springs, streams and rivers, and the favourable microclimatic potential for

⁵ Rulebook on conditions and a way of accomplishing the right to credit support, Official Gazette of RS, no. 30/14, 87/14 and 25/16.

intensive agricultural production in the field of fruit growing. The production of raspberry is related to this area the most, because this environment fits in all to raspberry. The climatic and land conditions are that favourable so they can provide the successful production of raspberry, along with the use of modern technology of growing and adequate agro-technical and pomo-technical measures. However, long-term or short-term droughts occur almost every year and they seriously jeopardize the production of raspberry. A particularly negative effect on the amount and quality of yields is achieved by drought in “the critical period” (phenophase from blooming to picking raspberry in June and July) when raspberry needs water the most. The intervention by irrigation becomes prominent and its use is the most effective, as in technological, as well as in economic sense. Irrigation „adapts itself“ in agricultural production of raspberry manufacturers from Arilje, so it isn't a real obstacle for „the fight“ against drought anymore.

Registered agricultural holdings of this area can count on incentives not only in raspberry production but in other fields of agricultural production from the budget of Ministry of Agriculture and the Environment Protection through the Directorate for Agrarian Payments. It is important to mention that, in determining the spatial-functional organization of the Arilje municipality area in future there should take care on every production factor which action must be respected during the investments planning and realization.

The yields of raspberry achieved so far are far away from those which can be achieved by taking into consideration the genetic potential of raspberry, but they are still satisfactory. Anyhow, Serbia is at the very top raspberry manufacturers in the world.

The essence of raspberry production with the use of irrigation is that it contributes to the growth of a holding's income and this income exceeds the growth of variable costs caused by irrigation, regarding that expenses for the application of this measure are not significantly represented in the structure of total variable costs.

As one of the important recommendations for the production of raspberry is also the use of renewable energy sources in the process of irrigation by solar panels and the introduction of this practice in Arilje raspberry-mount, since this achieves significant savings in irrigation and the investments in the purchase of solar panels refund quickly.

The state should coordinate programs and projects which promote the use of renewable energy sources and direct the financial support to users for the adoption and use of their results.

Literature

1. Allen, R. G., Pereira, L. S., Reas, D., Smith, M. (1998): „*Crop evapotranspiration*“. FAO irrigation and drainage paper, No 56. Rome.
2. FAO Bullten d'irrigation et de drainage (1984): *Precipitation efficace*. Rome. p.p. 1-40.
3. Gajić Boško, Tomić Zorica, Sredojević Zorica (2013): „*A simple method estimates and economic indicators of photovoltaic system for drip irrigation*“. Journal Economic of Agriculture. Year 60, No. 2 (217-436), pp. 223-237.
4. Kljajić Nataša (2012): „*Ekonomska efikasnost investicija u različitim uslovima proizvodnje maline*“. Doktorska disertacija. Poljoprivredni fakultet, Novi Sad.
5. Kljajić Nataša, Vuković Predrag, Arsić Slavica (2013): „*Tendencies related to the production of raspberries in the Republic of Serbia*“, Journal Economic of Agriculture. Year 60, No.1 (1-216), pp. 39-48.
6. Kljajić Nataša, Vuković, Predrag, Arsić Slavica, (2013): „*Current Situation in Irrigation in the Republic of Serbia*“, pp. 123-139. Charpeter 7, Sustainable Technologies, Policies, and Constraints in the Green Economy Web site: <http://www.igi-global.com/http://resources.igi-global.com/production/proofs/Jean-Vasile/EditorProof.pdf>
7. Kljajić Nataša (2014): „*Efikasnost investicija u proizvodnji maline*“. Monografija. Izdavač: Institut za ekonomiku poljoprivrede Beograd, broj strana 197.
8. Kljajić Nataša, Paraušić Vesna, Rodić Aleksandar (2016): „*Tehno-economic feasibility use of portable solar irrigation systems*“. 152nd EAAE Seminar: „Emerging technologies and the development of agriculture“. Thematic proceedings. Novi Sad, Serbia. pp. 36-57.

9. Milivojević Jordan (1984): „*Efektivne padavine*“. Prilog metodologiji određivanja režima navodnjavanja. Doktorska disertacija. str. 119-125.
10. Milivojević Jordan, Gajić Boško, Bošnjaković Gorica, Cević Nataša, Matović Gordana (2005): „*Optimizacija režima navodnjavanja zemljišta pod zasadima maline u različitim geomorfo-pedo-mikroklimatskim uslovima ariljsko-požeškog malinogorja*“. Završni izveštaj projekta tehnološkog razvoja u oblasti biotehnologije. str. 1-32.
11. Petrović S., Milošević T. (2002): „*Malina-Tehnologija i organizacija proizvodnje*“. Agronomski fakultet, Čačak. str. 215-219.
12. Sredojević Zorica, Kljajić Nataša, Popović Nikola (2013): „*Investing in raspberry as a opportunity of sustainable development of rural areas of western Serbia*“. Buletinul Revista categoria B+CNCISIS, Seria Stiinte Economice (M24), 2013, Petrol-Gaze din Ploiesti, 1/201, II (LXV), http://www.upg-bulletin-se.ro/archive/20131/6.Sredojevic_Kljajic_Popovic.pdf
13. Statistički godišnjak Republike Srbije, 2015. god.
14. <http://www.novosti.rs/vesti/naslovna/ekonomija/aktuelno.239.html:578520-Srbija-na-prvom-mestu-u-svetu-po-proizvodnji-malina>
15. <https://adavinic.wordpress.com/2016/04/26/poslovno-udruzenje-hladnjaca-srbije-i-svetska-organizacija-iro-organizuju-svetski-susret-malinara/>
16. <http://arilje.org.rs/privreda/poljoprivreda.html> (09.11.2016)
17. <http://www.ains.rs/predavanja/AINS-VOCARSTVO%20SANSa%20POLJOPRIVREDE.htm>
18. <http://www.novosti.rs/vesti/naslovna/ekonomija/aktuelno.239.html:601982-Malinjaci-najvece-fabrike-u-Srbiji>.

SUSTAINABLE DEVELOPMENT OF AGRICULTURE IN SERBIA AS A FUNCTION OF RURAL DEVELOPMENT¹

Stanislav Zekić, Bojan Matkovski²

Abstract

The preferred model of agricultural development has evolved from the concept of conventional agriculture to multifunctional agriculture model, which links all the functions that are contained inside the previously developed models of agricultural production. Multifunctional agriculture in the European Union (EU) was promoted as the European model of agriculture development, so in last period it has been increasing share of agricultural budget directed to farms whose activities are in accordance with the multi-dimensional aspect of agriculture. Agro-ecological conditions for agricultural production, as well as the structure of farms in Serbia, are characterized by a relatively pronounced heterogeneity. Although there is still a high dependence on the rural economy of the primary sector, agriculture contributes less socio-economic vitality of rural communities. The solution is seen in the diversification of the rural economy, where the multifunctionality of agriculture can play a significant role.

Keywords: *Sustainable agriculture, rural development, multifunctionality, Serbia.*

Introduction

Powerful economic, environmental and social pressures arise as a result of conventional agricultural production. It has influenced the evolution of agricultural production systems, i.e. the development of the concept of

¹ This paper represents a part of the research on the project of the Ministry of Education and Science, Republic of Serbia, No. 46006, entitled: *Sustainable Agriculture and Rural Development in terms of the Republic of Serbia strategic goals implementation within Danube region.*

² Stanislav Zekić, PhD. associate professor, zekics@ef.uns.ac.rs, +381214852923; Bojan Matkovski, assistant, bojan.matkovski@ef.uns.ac.rs, +38124628046; Department for Agricultural economics and Agri-business, Faculty of Economics in Subotica, Segedinski put 9-11, University of Novi Sad, Serbia.

multifunctional agriculture. This model focuses on the "non-market" outputs of agriculture that are primarily aimed at improving the quality of life in rural areas, environmental protection, the realization of food security, the preservation of the landscape as well as cultural and historical heritage of rural areas, providing high quality and safe food as well as animal welfare. This concept, which is predominantly present in the EU, for Serbia represents a guideline for the alignment of their own agricultural and rural policy, on the road to full membership in the EU.

Evolution of Agricultural Production

In the middle of the last century rapid technical and technological changes in the sphere of agricultural production took place, which have had significant effects on the improvement of the production itself, which, among other things, led to the gradual distancing from conventional agriculture. Growing social pressure as a result of the changed expectations of agricultural production is also a factor that caused the growth of importance of additional functions that are attached to agriculture. In fact, farmers have begun to produce significant effects (in socio-economic sphere, but also in the environment), both at local and at national and global level, and the role of agriculture in recent decades significantly changed compared to its traditional role. The contribution of agricultural production which cannot be evaluated only through its share of production, income or employment, nor the farmers can be seen exclusively as food manufacturers. As a result, it has been developed a number of alternative farming systems, and *Figure 1* shows the evolution of agricultural production systems by P. Vereijken (also mentioned at Bogdanov and Đorđević-Milošević, 2005).

Conventional agriculture aims to produce food for the urban and rural population and providing employment and income for rural population. A primary focus of this concept is to increase agricultural production and full employment of labor at the farm. This model of agriculture has an imperative in productivity growth, and it is predominantly based on the use of non-agricultural inputs - mechanical and biochemical, all in order to increase the productivity of primary production factors labor and land. This concept of agricultural production significantly contaminates the environment and has a negative impact on biodiversity.

Integrated agriculture in addition to production, labour and income, in focus has the protection of the environment, in order to minimize the

negative effects caused by conventional agriculture. This concept is a reaction to the excessive use of chemicals, and has the intention in the reduction of its application in order to reduce negative effects on the environment. Integrated agriculture brought to the fore the problem of pollution of agro-environment and thus contributed to the growth of awareness of the importance of this problem.

Figure 1. *Evolution of agricultural production*

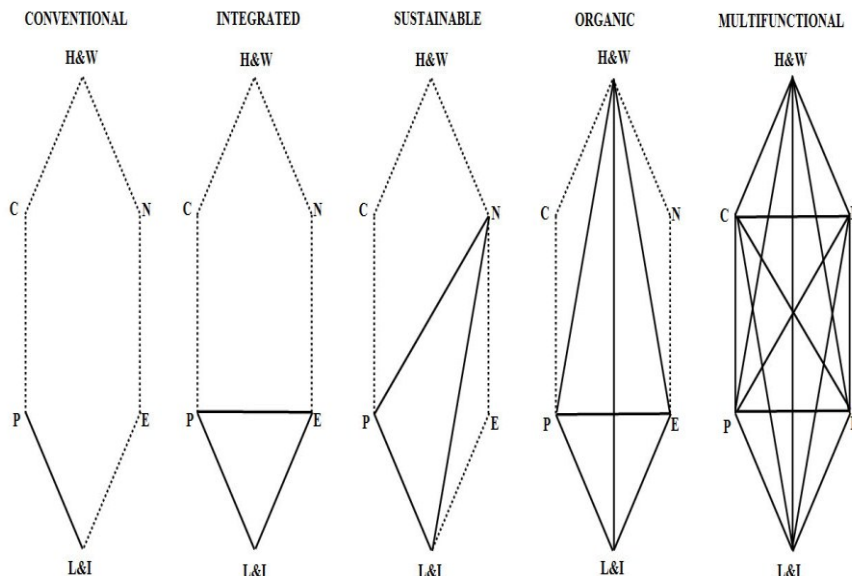

H&W - HEALTH AND WELFARE; C - CLIMATE; N - NATURE; P - PRODUCTION; E - ENVIRONMENT; L&I LABOUR AND INCOME.

Source: *Bogdanov and Dorđević-Milošević, 2005.*

Sustainable agriculture, as the next evolutionary stage in the evolution of agricultural production, contains three aspects of sustainability: social, economic and environmental. The social dimension refers to the creation of a satisfactory quality of life of the rural population. The economic dimension refers to the effective use of resources and achievement of competitiveness and vitality of rural economy. The environmental dimension should ensure the preservation of production resources to meet the needs and future generations. In fact, farmers have a significant impact on the eco-system, both at local and at national and global level, and sustainable agriculture should be based on technologies that maximize productivity and simultaneously minimize the negative effects

on both the environment and the human factor (Stojanović and Manić, 2010). Sustainable agriculture is focused on the agricultural areas that are of high importance for nature and the environment, particularly in marginalized areas.

Organic agriculture, as an alternative concept to production, processing, trade and consumption of agricultural products, is based on the avoidance of high impact and chemical inputs to agricultural production, in order to protect human and animal health, as well as the environment. Thus, the goal of organic agriculture is production of safe food with more environmentally friendly production methods. However, yields in organic farming are lower than in conventional production, and differences in cost effectiveness are deep, so organic agriculture is still minor alternative to conventional agriculture.

Multifunctional agriculture has been made with strong economic, social and environmental pressures in order to overcome the above mentioned limits of agricultural production systems. The concept of multifunctional agriculture, in addition to the production itself, includes the protection of the environment (water, soil and air), the sustainability of the natural and agro-historical ambience, climate control and the effects of global warming, as well as health care and overall well-being (including tourism and recreation). This concept is fairly new, so multifunctional agriculture as the term was first mentioned in the last decade of the last century, and at the Earth Summit in Rio de Janeiro in 1992, where the multifunctional aspect of agriculture has been linked to food security and sustainable development. The basic idea of multifunctional agriculture focuses on activities that are not exclusively related to the production of food and fiber, but also for "non-market" activities of agriculture, or the "invisibles" outputs. Invisibles outputs are characterized as externalities, and public goods in general means (Zekić, 2008):

- creation of viable rural communities;
- biodiversity conservation and environmental protection to the agricultural land;
- achievement of food security;
- preservation of landscape and cultural and historical heritage of rural areas;
- quality assurance and food safety and
- improvement of the conditions of livestock.

European Path - Model of Multifunctional Agriculture

In recent decades, agriculture of EU is faced with a number of challenges that significantly influence the change of the role of agriculture in modern society. These challenges are related to market liberalization and globalization, and it has resulted in the emergence of a large number of countries in the global market, which have low production costs and that represent direct competition for European producers. For many years the main objective of the Common Agricultural Policy (CAP) was the increase in world market share. Because of the high price support, EU became one of the major exporters of food in the world. However, the manner in which it has developed CAP, as well as new international challenges, has led to the problem and the need to reform the CAP, and to redefine the role of agriculture in society. In this context, multifunctional agriculture in the EU has been marked as a central principle of the future support of agriculture, which has promoted multifunctional character of "European" agriculture.

Decades of modernization of agriculture, manifested through specialization, negative external effects, the growth of income disparity within the agricultural sector, did that this development of agriculture becomes practically untenable. The new role of agriculture in the society and economy of the EU is determined by the changing demands of the urban population in relation to agricultural production. Rural areas today represent not only the production space, but the space that needs to meet a variety of other purposes, such as environmental protection, preservation of traditional values of rural areas themselves, the need for recreation, sport, amusement, as well as the cultural and historical aspect of land use. In addition, the growing demands for agriculture enable social cohesion and economic sustainability and relatively small farms, which are much easier to be transformed into a new multifunctional production-service "enterprise". New types of farms should possess a combination of agricultural and non-agricultural activities, which will have positive effects on costs, profits, risks and development prospects. Coordination and allocation of family labor force between these activities in multifunctional farms proves to be a significant source of synergies (Ploeg and Roep, 2003).

Multifunctional character of European agriculture is in line with the policy of rural development which is gaining importance in the EU's development priorities in recent decades. That policy favors the

development of, already mentioned, multifunctional farms, by promoting the creation of non-agricultural activities in rural areas. It is imperative to create physical and social infrastructure and to reduce rural poverty, as well as to limit the negative environmental effects. In that context, it appears rational determination of the Union to abandon the policy of unlimited support to agriculture, and the increasing allocation of funds to the rural development programs. Rural development programs have an influence on increase of the quality of life of the rural population as well as on reduction of negative external effects. The ultimate goal is sustainable rural development in which multifunctional agriculture is one of the starting points.

The emergence of the concept of multifunctional agriculture, in addition to the aforementioned reasons, is associated with the need to reform the CAP in order to present European agricultural policy in a politically acceptable concept to the World Trade Organization (WTO), in order to subsidize agricultural producers in future.

Multifunctional character trying to justify income support to agriculture and market intervention, i.e. to weaken or avoid international obligations in the reduction of support measures to agriculture that have a distorting effect on international trade. The issue of multifunctionality will definitely pose a point of contention within the framework of multilateral trade negotiations between the most powerful member of the WTO, US and EU (Lovre, Gajić and Zekić, 2005).

For the reform of the CAP after 2013 the foundation was set up by reform of 2003, while preparations for further directing of the new CAP in the period 2014-2020 started with "health control" in 2008. By public hearings on the elements and objectives of CAP for this period it was concluded that the reform of CAP is necessary due to the increased demand for food, higher consumer expectations, the need to strengthen the competitiveness of EU agriculture, and to establish a balance in the distribution of resources (Matkovski and Kleut, 2014).

In *Chart 1* is evident that market support and coupled payments were significantly reduced, with the accent on direct payments independent of production volume, as well as the continuation of the promotion of rural development policy.

Chart 1. *Distribution of CAP budget*

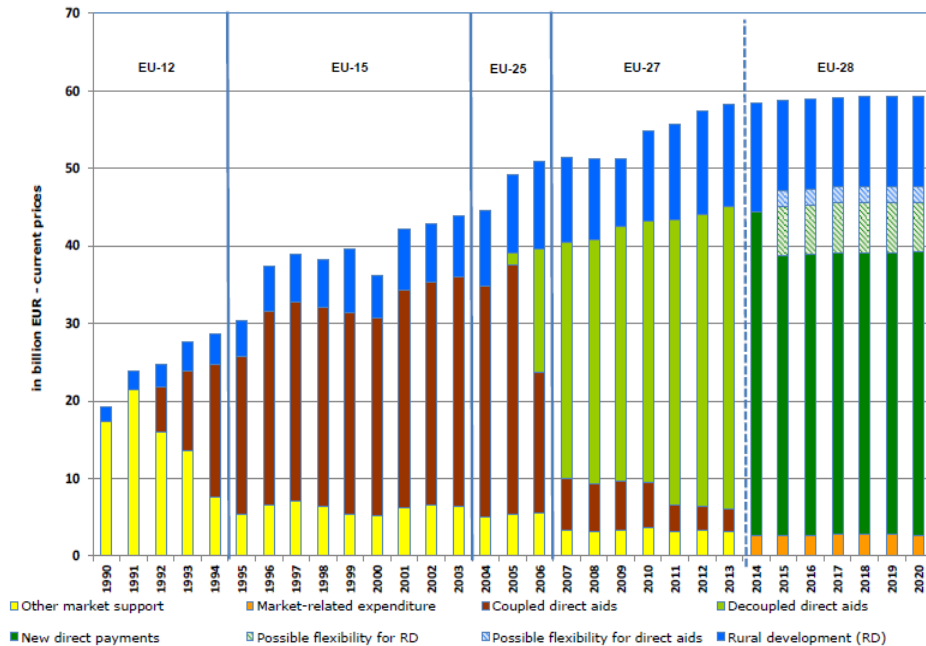

Source: *European Commission, 2013.*

Changes of CAP in the past led the principle of "public money for public goods" which means that farmers are rewarded if they contribute to environmental protection. As a new component of the first pillar a new instrument - the "greening" is introduced, which in fact represents one of the major changes of the CAP in the period 2014-2020 (Matthews, 2013).

Serbian Agriculture and Sustainable Rural Development

Serbia is a candidate for the EU membership since 2012, so the changes in CAP have significant implications on agricultural and rural policy in Serbia, which is in pre-accession negotiations with the EU. Customizing agricultural and rural policy to European, as well as its complete adaptation after accession to the EU, will have implications both in the agricultural sector, and in the overall economy of Serbia. These processes will require the full adjustment of the domestic agricultural policy, which will, among other things, lead to favor the concept of a multifunctional agriculture. In other words, the upcoming harmonization of national agricultural and rural policy with CAP, will increase the importance of applying multifunctional concept into a supporting Serbian agriculture.

Modern agricultural and rural policy promotes a regional approach, taking into account local specificities. This is important for Serbia due to the relatively pronounced heterogeneity of rural areas, as well as agro-ecological conditions for agricultural production. On one side is the Vojvodina, the northern region of Serbia, which has very favourable natural conditions and potentials for agricultural development and for improving the quality of life in rural communities. On the other side there are the mountain areas of southern and eastern Serbia, which according to their developmental characteristics indicate significant limitations, and require different approaches. Also, the differences are present in the agro-environment, socio-economic characteristics, which will be reflected on the possibility of applying the European model of agriculture (Zekić, Matkovski and Kleut, 2016).

The Ecological Aspect of Sustainable Agricultural and Rural Development

Environmental policy of the negative effects that produce agricultural production in Serbia does not have adequate importance. Intensive agricultural production on large social, state farms during the socialist regime is the main reason for the negative effects of agriculture on the environment. Institutionalization of agriculture and negative policy towards the environment is consequence of negative impacts on the environment, while on the other hand, ownership of agricultural land did not guarantee an adequate conservation of nature (Birovljev, Matkovski and Četković 2014). According Zekić and Gajić (2005) increasing pollution of land, water and air is present in Vojvodina, where the dominant presence of large agricultural farms, in relation to the areas of central and southern Serbia where small family farms are dominant.

Directions for environmental policy from the negative effects of agricultural production are defined in the Strategy of Agriculture and Rural Development of Serbia from 2014. As one of the strategic objectives of this document is outstanding and sustainable resource management and environmental protection, while concrete measures to improve the environment for the next period will be established by the new National Rural Development Program. The specificity of the nature of agricultural production, in terms of its high dependence on the volume and quality of natural resources are objectively given, so it imposes the necessity of keeping adequate policies in order to preserve the vitality of the resource

for future generations. Because of that there is a necessity of responding to climate change, protection of agricultural land from permanent change of use, reducing greenhouse gas emissions, protection of biodiversity and the typical rural landscapes, rational use of water resources, forests and other natural resources in rural areas. That requires the definition of a new policy that takes into account the multifunctional character of agriculture (Official Gazette of the Republic of Serbia 85/2014).

In the framework of the agro-environmental policy, it is necessary in the next period to work on raising awareness of producers about the need to protect and improve natural resources. In addition, agri-environment policy should be created according to specific national, regional and local needs. Policy support should gradually take the outlines of a system which is harmonized with the EU, and that requires strengthening of the capacity of the administration in implementation and monitoring of legislation in the field of environment.

Although there are no great interests for the implementation of agro-environmental programs, except in the legally protected areas, in the future it should be devoted much more attention to the adjustment to the EU policy. Namely, in the context of a CAP agro-environmental measures are a component of the rural development programs of the EU, so incentives from budget receive only those farmers who practice the methods compatible with the growing need to protect and improve the environment and natural resources, as well as land and genetic diversity.

The process of harmonizing legislation with the EU in the framework of agro-environmental policy for Serbia include the following (Zekić and Gajić, 2005):

- adaptation and change of national legislation, standards and procedures in line with EU standards;
- preparation of budgetary institutions and the need for the adoption of laws and regulations, and
- preparation of the necessary controls and sanctions, which will fully guarantee the implementation of the law.

One of the ways that has positive impact on the environment is the organic agriculture that respects the ecological balance, but it can also affect the quality and safety of food which is very important for human health. The investment in the development of organic agriculture are in

accordance with the principles of permaculture and they are impassable, so they represent the base of the efficiency of biodiversity conservation, as well as the survival of people, not only from the aspect of environmental protection and improvement of human health, but also from the standpoint of economic prosperity (Birovljev and Četković, 2014). Also, the pre-accession support from EU for candidate countries by providing funds from IPARD (*Instrument for Pre-Accession Assistance for Rural Development*) envisages support to agro-ecological and climatic conditions, as well as measures of organic production.

Socio-economic Aspects of Sustainable Agricultural and Rural Development

Analyzing demographic indicators in rural areas is important because the labor force in agriculture is linked to the village and agriculture, and because the rural labor force, and in particular rural, is poor mobile. Rural population according to Census of Population 2011 shows a less favorable demographic characteristics than the urban population. In both urban and rural population with the age groups of children and young labor force showed a significant decline, but the extent of changes is much more pronounced among the rural population, while in the category of middle-aged labor force decreasing trend is also very strong in the rural population. The educational structure of the rural population is less favorable compared to urban, and there is very low percentage of people with higher education (Bogdanov and Babović, 2014).

A significant contribution to the rural economy of Serbia can provide diversification of income and activities in rural areas, and moving away from agriculture towards secondary and tertiary activities. Employment opportunities outside agriculture contribute to greater economic self-reliance of rural areas, and that led to productivity growth of agriculture. Farms more often diversify their income through activities on jobs outside the farm, while the diversification on the basis of other profitable activities on the farm is less frequent. This is characteristic of less developed rural areas.

Representation of farms with other profitable activities in Vojvodina is considerably less than other regions in Serbia, primarily due to the production structure that is based on capital-intensive lines and thus less surplus labor force that would be involved in these activities. Also, it led to greater specialization and focus of farms towards agriculture in

Vojvodina. On the other hand, there is Šumadija and western Serbia, with the highest level of diversification of production (Bogdanov and Babović, 2014). Otherwise, this region excels in Serbia in terms of development of rural tourism.

Rural tourism is increasingly seen as an important factor in achieving economic sustainability, social reconstruction and improvement of the living conditions of rural communities. In rural areas where agriculture is dominant, tourism can be a significant source of additional income for small family farms. With development of rural tourism it can be established the basic prerequisites for young people to stay in the rural area. It should be based on the integration capacity of the offer in rural tourism and branding them on the market (Birovljev and Štavljanin, 2011).

Sustainable Development of Rural Areas

The concept of multifunctionality and sustainability of agriculture and rural development have the same basis. Both concepts are based on the multidimensional role of agriculture and its production of market, as well as non-market output. Agriculture is seen as the basis for the diversification of the rural economy in terms of promotion of complementary activities (Stojanović and Manić, 2010). This concept is consistent with the primary mission of rural development - increase the quality of life of the rural population, which should be achieved primarily by increasing employment opportunities and income growth.

Rural areas of Serbia are relatively important national resource in terms of territory, population and economic potential. However, socio-economic development indicators in rural areas are not favourable: demographic characteristics, education level of the population, the availability of the service sector, infrastructure and economic development in general lag behind urban areas (Zekić and Matkovski, 2015). Agriculture, although it cannot be a "guarantor" of social security of the rural population, is still the most important economic activity in rural areas. Also, the semi-natural model of agriculture, which is present at large number of farms, represents a sort of "economic shock absorber" and contribution to the total production of these farms is not negligible.

Improving the quality of life of rural residents, and improving the socio-economic situation of people living in the rural areas, through the equitable share in the distribution of income and economic opportunities are

extremely important aspects of sustainable rural development which Serbia aspires. Changes in the socio-economic structure, as well as changes in the agricultural sector, led to a reduction in the number of farms in this area, and it is likely that these trends will continue in the future. It is extremely important that this process is economically viable and that it has no negative impact on rural areas. It imposes the necessity of creating favorable conditions for life and work of younger and more educated population groups, in order to maintain them in rural areas through the provision of attractive jobs and equal opportunities for their families.

Chart 2. *Support to agriculture and rural development in Serbia*

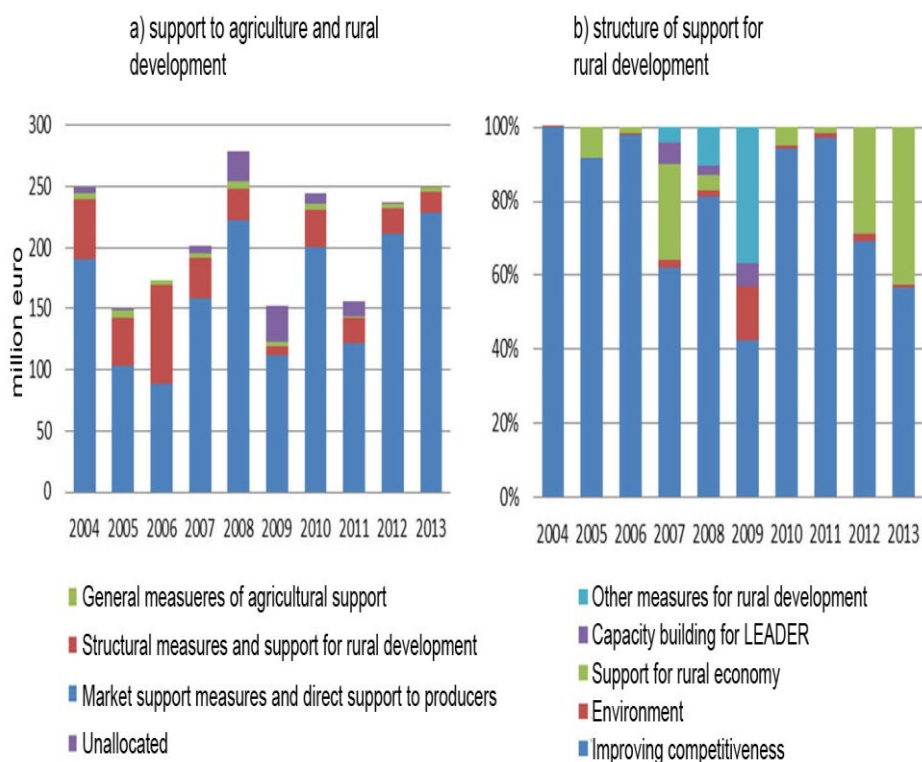

Source: *Strategy of Agriculture and Rural Development of Republic of Serbia in period 2014-2024*

The greater importance of rural development measures is provided by the new Law on Agriculture and Rural Development in 2013, and the reason is certainly the status of candidate country for the EU membership in 2012. Status of candidate country will allow the use of IPA (*Instrument for Pre-Accession Assistance*) funds, which define the

scope and type of support intended for candidate countries and potential candidates for EU membership. In the previous period, the financial support from the IPA funds, was partly used for agriculture and rural development to establish a system of accounting data on the farm - FADN (*Farm Accountancy Data Network*), and then to support the Directorate for National Reference Laboratories, support for food security, improvement of well-being animal and control, as well as capacity building for the implementation of IPARD.

Extremely important impact on rural development in Serbia in the future may have IPARD funds, which are related to rural development support. These funds will be awarded exclusively for the planned projects that will contribute to the realization of the priorities set in the EU strategic documents. IPARD II program for Serbia was adopted at the end of 2014 for the period 2015-2020 and budget for this programme is about 175 million euro. The experience of countries in the region, which in the previous budget period were beneficiaries of IPARD funds, shows that the biggest share of funds was directed towards improving the competitiveness of agricultural producers, but also to the establishment of producer organizations, improving rural infrastructure, rural tourism development, improving labor advisory services, and to agro-environmental measures.

The largest share of these funds intended for Serbia, scheduled for investments, which can be a significant incentive for the introduction of new activities on farms. The only question is how much of an effect IPARD funds have on small farms. It is assumed that most of the funds attract larger farms, and that the process of their modernization will have greater effects on the growth of employment, so that the dominant part of the rural population will not feel the effects of such dimensioned support (Zekić, Matkovski and Kleut, 2016).

Conclusion

During the past decades, through the creation of different systems of agricultural production, it has been improved the awareness of the changing roles of agriculture and its integration with rural development. These tendencies are also present in the EU, where there has been a redirection from sectoral policies, which in the foreground had agriculture towards multifunction agricultural development and strengthening of rural development policy. In the light of future EU membership, in the next

period, Serbia is expecting considerable harmonization of agricultural and rural policy with the Common Agricultural Policy of the EU, so programs of multifunctional development of rural areas will get a greater significance. In this context, the pre-accession funds of the European Union for agriculture and rural development can be generators of further development of the multifunctionality of agriculture in terms of sustainable agricultural and rural development. Of course, the further development of agriculture must be based on knowledge, new technologies and quality standards, to meet the needs of consumers in the domestic and international markets, while protecting the income of agricultural producers. Also, it is necessary that the environment, natural resources and cultural heritage is managed according to the principles of sustainable development in order to develop rural areas.

Literature

1. Birovljev J., Četković B. (2014): *Organska proizvodnja i permakultura u funkciji ekonomske efikasnosti agroprivrede Srbije*. 19. Internacionalni skup SM2014 Strategijski menadžment i sistemi podrške odlučivanju u strategijskom menadžmentu, Ekonomski fakultet u Subotici.
2. Birovljev J., Matkovski B., Četković B. (2014): *Poljoprivreda i zaštita životne sredine Srbije u funkciji prilagođavanja Zajedničkoj agrarnoj politici Evropske unije*. Anali Ekonomskog fakulteta u Subotici, 50(2), 17-29.
3. Birovljev J., Štavljanin B. (2011). *Ruralni turizam u funkciji razvoja ruralnih ekonomija lokalnih zajednica u Srbiji*. Ekonomika poljoprivrede, 58(SB1), 41-46.
4. Bogdanov N., Babović M. (2014): *Radna snaga i aktivnosti poljoprivrednih gazdinstva*, Republički zavod za statistiku, Beograd.
5. Bogdanov N., Đorđević-Milošević S. (2005): *Multifunkcionalna poljoprivreda – koncept i institucionalni okvir*. Tematski zbornik – *Multifunkcionalna poljoprivreda i ruralni razvoj*, Institut za Ekonomiku poljoprivrede Beograd, 14-22.

6. European Commission (2013). *Overview of CAP reform 2014-2020*, http://ec.europa.eu/agriculture/policy-perspectives/policy-briefs/05_en.pdf (05.02.2014.)
7. Lovre K., Gajić M., Zekić S. (2005): *Multifunkcionalna poljoprivreda u pregovorima Svetske trgovinske organizacije*, objavljeno u ed. Cvijanović D., Popović V., Subić J., Savić M., Bukvić R.: "Multifunkcionalna poljoprivreda i ruralni razvoj", Institut za ekonomiku poljoprivrede, Beograd, 37-45.
8. Matkovski B., Kleut Ž. (2014): *Integracioni procesi i politika ruralnog razvoja u funkciji konkurentnosti i ekonomske efikasnosti agroprivrede Srbije*. 19. Internacionalni skup SM2014 Strategijski menadžment i sistemi podrške odlučivanju u strategijskom menadžmentu, Ekonomski fakultet u Subotici.
9. Matthews A. (2013): *Greening CAP payments*. Dublin: The Institute of International and European Affairs.
10. Ploeg J. D., Roep D. (2003): *Multifunctionality and rural development: the actual situation in Europe*, in: Van Huylenbroeck G., Durand G. (eds.): "Multifunctional Agriculture, A New Paradigme for European Agriculture and Rural Development", Ashgate Publishing Limited, Aldershot, 37-53.
11. Official Gazette of the Republic of Serbia 85/2014. Strategy of agriculture and rural development of Republic of Serbia in period 2014-2024. <http://www.mpzss.gov.rs> (29.02.2016.)
12. Stojanović Ž., Manić E. (2010): *Cross-border cooperation, protected, geographic areas and extensive agricultural production in Serbia*, Economics of Agriculture, Belgrade, 57(SI-1), 79-90.
13. Zekić S. (2008): *Reforma agrarnih politika i restrukturiranje poljoprivrede zemalja jugoistočne Evrope u procesu evropskih integracija*, Doktorska disertacija, Ekonomski fakultet Subotica, Univerzitet u Novom Sadu.
14. Zekić S., Gajić M. (2005): *Politika zaštite agro-okruženja u Evropskoj Uniji – implikacije na poljoprivredu Srbije i Crne Gore*, Posebno tematsko izdanje časopisa Ecologica, Beograd, 10, 349-354.

15. Zekić S., Matkovski B. (2015): *Razvojne mogućnosti ruralnih područja Srbije*, Zbornik Matice Srpske za društvene nauke, 66(4), 757-771.
16. Zekić S., Matkovski B., Kleut Ž. (2016): *IPARD Funds in the Function of Development of Rural Areas of Serbia*, Ekonomski horizonti, 18(2), 169-180.

RISKS IN THE PRODUCTION OF ORGANIC FOOD¹

Željko Vojinović², Drago Cvijanović³

Abstract

Agricultural production is very important economic branch in Serbia. Its significance reflects in the production of sufficient quantity of food for population in our country, but at the same time, substantially for the production of food surplus, which could export. In modern economic conditions, an economic activity, especially in high-developed economic systems, has an intensive use of technology and high productivity. The question is whether to go in direction of high-productive agricultural production or in direction of the production of much better organic food. Organic food production implies the use of knowledge while using the available agricultural capacities, but on sustainable bases, the production of high-quality and healthy-safe products which have a higher price on the market with less productivity, where it appears the economic risk of the cost-effective production process. For the production of organic food uses only 0.3% of agricultural arable land in Serbia. This percentage in Europe amounts around 24%, especially in Italy and Spain, which is a chance for our agricultural manufacturers to direct their capacities to this production, surely with adequate market and prices, strengthening of competitive ability and direction to export.⁴The state role can be very significant in that process, which can further affect positively GDP, the increase of public revenues, etc.

Key words: risks, healthy food, agriculture, production, Serbia.

¹The paper is a part of research at the project 46006 “Sustainable agriculture and rural development in terms of the Republic of Serbia strategic goals realization within the Danube Region”, financed by the Ministry of Education, Science and Technological Development of the Republic of Serbia.

²PhD Željko Vojinović, University in Novi Sad, Faculty of Economics in Subotica, Department of Finance, Banking and Accounting and Auditing, Segedinski put 9-11 Street, 24000 Subotica, tel.: 00 381 24 628 000; 00 381 24 628 030, e-mail: zeljko.vojinovic@ef.uns.ac.rs

³Drago Cvijanović, Ph.D., Full Professor and Principal Research Fellow, Dean of the Faculty of Hotel Management and Tourism – Vrnjci Spa, University of Kragujevac, Vojvodjanska 5A Street, Vrnjacka Banja, Serbia, tel. +381 63 295 111; E-mail: drago.cvijanovic@kg.ac.rs;

⁴http://www.kombeg.org.rs/aktivnosti/zadruzni_savez/Detaljnije.aspx?veza=326, (13.09.2016.)

Introduction

Agricultural manufacturers were focused on achieving higher productivity together with the increasing number of population and in order to make a higher profit. Technical achievements, the progress of science and the development of biotechnology have ensured higher yields with fewer investments and to replace labour with the modern mechanisation. Aiming to satisfy the increasing needs and make a bigger profit, the society, at one point, has forgotten to live healthy. The term organic or healthy diet appears after the I World War.

Foundations of the healthy food production were laid by Rudolf Steiner from Germany, in 1924, in lectures Course of Agriculture in eight lessons. Müller H. joined him with the Peasant movement. Sir Albert Haward was published a book called *An Agricultural Testament*, in which basic directions of the organic agriculture development were presented. J.J. Rodale (USA) had started in 1942 to publish the first journal on the organic agriculture.

The first movement *The Living Soil* was founded in Great Britain in 1943, and the first association of organic manufacturers *The Soil Association* in 1946. The first international organization for the organic production was founded in 1972 called *International Federation of Organic Agricultural Movements* (IFOAM), which today has over 750 associations from 111 world countries.

At the beginning of nineties in XX Century has started with the regulation of this field. The Law on Organic Production was adopted in USA in 1990, while the Regulation 1992/91 was adopted in EU in 1991. After eight years, more accurately in 1999, the International Standards for the Organic Food Production Codex Alimentarius (FAO/WHO) were put into effect.

The organic production is a system of sustainable agriculture which bases on a high respect of ecological principles by a rational use of natural resources, use of renewable sources of energy, preservation of natural diversity and environmental protection.⁵

⁵Simić, I., (2015), *Organska proizvodnja-neiskorišćen potencijal Republike Srbije*, Support Programme Strengthening Civil Society, Norwegian Embassy, p 3

Although they occupy only 1% of total world food market, the organic products become more and more required commodity in the world and the share of these products in world trade flows is increasingly significant. Constant growth of demand for the organic products in the world point out that this production method can be very profitable if natural resources, knowledge and production experience are used in a proper way. Manufacturers and consumers all over the world see the economic and ecological advantages of this form of agriculture.⁶

Food produced by the organic agriculture principles doesn't contain any artificial synthesized matters or pesticides. It provides a higher nutrition value to products unlike those produced by conventional production. Studies in Germany have shown that these products have significantly higher content of oligominerals, especially potassium and iron, and also a higher level of magnesium, phosphorus and vitamin C. Similar results were reached also in America, where it was established that these products had 63% more potassium, 73% more iron and 125% more calcium than products obtained by conventional agriculture.⁷

The issue of the organic healthy food production in Serbia isn't still strategically set as a goal and possibility for development. This theme has become topical just in late seventies of XX Century. Often the term of organic production was equated with traditional production, and a standard of living wasn't provided higher demand for healthy food of organic origin.

The first law related to organic production was adopted in time of the Federal Republic of Yugoslavia. At that time, first investments and projects arrive and they motivate more and more farmers to commit their selves to study of the process of convention and therefore training and reporting of farmers would be brought to a higher level. Numerous well-known organizations in this field have supported this form of agricultural awareness. Some of them are „Avalon“ from the Netherlands, „Sida“ from Sweden, as well as „Diaconia“ from Germany.⁸

⁶All the same

⁷<http://www.tehnologijahrane.com/enciklopedija/organska-hrana>, (13.09.2016.)

⁸[http://www.kombeg.org.rs/Slike/CeTranIRazvojTehnologija/2015/jun/Organska%20poljoprivreda%20u%20Srbiji%](http://www.kombeg.org.rs/Slike/CeTranIRazvojTehnologija/2015/jun/Organska%20poljoprivreda%20u%20Srbiji%20), (13.09.2016.)

In historical sense, the organic food production in Serbia was of great concern just in eighties of XX Century. In 1990 in Subotica were opened stores in which were sold organic food. In that time, the association for organic food „Terra’s“ was founded.⁹

National Association for Organic Production Development (NASO) was founded in 2009 in Serbia, aimed to stimulate the organic food agricultural production. Only 0.3% of total agricultural arable land in Serbia is used for organic production. It is enough to say that Vojvodina has 1,628.000 hectares of arable land, while the whole Austria has 1,618.000 hectares. This speaks on the insufficiently used capacity.

Due to utmost importance of agriculture for the economic stability and sustainable development, adjusting domestic policy and legislature to Common Agricultural Policy of EU (CAP) is very important regarding that it will provide a range of values for agrarian sector in Serbia.¹⁰

There are 43.1 million hectares of agricultural land under organic production in the world, or 1% of totally used agricultural land. Global sales of organic food and beverages in 2013 was achieved the value of 72 milliard USD. Besides the existing discussions whether the organic food is better than the conventional one, revenues from sales of organic products in regard to 1999 are increased for almost five times, and as predicted is this growth in the future.¹¹

Potential of organic agricultural production in the Republic of Serbia

The Republic of Serbia occupies the territory of 8,840.000 ha. Agricultural area covers 5,346.597 ha, or 60%, of which the used agricultural area is 3,437.423 ha and arable area is 2,513,154 ha. Difference between the utilised and arable area are mostly meadows and pastures.¹²

⁹[http://www.poljoprivreda.infohttp://poljoprivreda.info/?id=723&oid=25%3Fref=Guzels_TV_\(16.09.2016.\)](http://www.poljoprivreda.infohttp://poljoprivreda.info/?id=723&oid=25%3Fref=Guzels_TV_(16.09.2016.))

¹⁰<http://www.europeanpolicy.org.dokumentacioni-centar>, (22.09.2016)

¹¹Simić, I., (2015), *Organska proizvodnja-neiskorišćen potencijal Republike Srbije*, Support Programme Strengthening Civil Society, Norwegian Embassy, str.3.

¹²Birovljev, J., Vojinović, Ž., Balaban, M.,(2015), *Potencijal poljoprivredne proizvodnje uticaj na premiju osiguranja*, Economics of Agriculture, Belgrade, ISSN 0352-3462, UDK 338.43:63, pp.705-723

Holding size and the total number of households show indentation which can substantially have an influence on the effects of production, individually or by a household. Thus we have 631,622 agricultural holdings, 628,555 family agricultural holdings and 2,567 registered legal entities in Serbia.

If we observe from a size of holding point of view, Serbia has 5.3 ha, Malta 0.9 ha and the Czech Republic 152.4 ha. Banat region has the largest arable areas of 1.23 ha per capita, while Serbia has in average 0.5 ha per capita. The average value of harvested crops and picked fruits per ha on the fields of agricultural manufacturers in this analysed period was around 900 €. The value of total production on arable area was amounted around 3.3 milliard euro.

These data point out to a relatively small number of smaller households, which is the possibility for agricultural manufacturers to turn to the healthy food production, not substantially technically dependant.¹³

Serbia certainly has a great natural potential to be engaged in organic production. Result is primarily its favourable geo-strategic position, the temperate continental climate belt, but also a preserved agro-system and quality land characteristics in regard to high-developed European countries. Over 80% of land is uncontaminated, because it doesn't contain heavy metals and harmful organic matters.¹⁴

According to collected data of the Ministry of Agriculture and Environmental Protection in 2013, less than 0.3% of totally used agricultural area, more accurately 8.228 hectares or 0.23%, was used for the production of organic food. In next spreadsheet we can see that areas under organic production increase from year to year.

Table 1. *Review of areas for the organic food production by years*

Year	2010	2011	2012	2013	2014
Hectares	5,855	6,335	6,340	8,228	9,430

Source: *Ministry of Agriculture and Environmental Protection*

¹³Cvijanović Gorica, Cvijanović, D. and Dozet Gordana. (2013). *Menadžment u organskoj biljnoj proizvodnji*. Institute of Agricultural Economics, Belgrade. Totally 366 pages. CIP 631.147. ISBN 978-86-6269-020-3. COBISS.SR-ID 197065740.

¹⁴Ivanović, M., Ivanović, B.,(2016), *Šanse i prepreke za razvoj organske proizvodnje u Srbiji*, Faculty of Agriculture in Belgrade, p 6

As it is shown in the table, the areas of arable land under organic production in 2014 were exceeded 0.28%. The most proportioned crops in 2013 were: maize (964.9 ha), soy (410.2 ha), lucerne (398 ha), barley (372.6 ha), raspberry (341.1 ha) and apple (334.9 ha) which can present in the following way.

Table 2. *The most common crops in organic production*

Crop	Maize	Soy	Lucerne	Barley	Raspberry	Apple
2013 %	11.7	4.9	4.8	4.5	4.2	4.1

Source: *Authors*

Organic production of cereals and fruits in the year 2014 was the most common. Crop growing has the share of 35%, fruits 28%, industrial plants 16%, forage crops 15% and vegetables 2%. Review of used areas in the production of organic products was given in the table below:

Table 3. *Organic vegetable production in 2013 and 2014 per hectare*

Description	2013	2014
Cereals	2,273.4	2,818.3
Fruits	1,484.4	2,202.1
Industrial plants	1,484.4	1,227.8
Forage crops	594.9	1,204.1
Vegetables	106.8	153.6
Other	212.8	271.4

Source: *Ministry of Agriculture and Environmental Protection*

According to research of GIZ in the year 2010, around 60% of agricultural manufacturers are engaged in their organic production on area smaller than 6 ha. Land is mostly cultivated by members of holding, while rarely employs an additional labour, mostly for jobs of great concern which must be done in a short-term. Around 25% carry out their production on areas which range from 10 to 20 ha of land. Depending on the characteristics of a plot on which production is planned, agricultural manufacturers decide for certain varieties. Larger plots are intended for oleaginous plants, and smaller for berry fruits and vegetables. The risk that agricultural manufacturers have when they start the organic production is high, especially for the first time, and smaller areas they use mainly for the organic production in order to satisfy their own needs.

Whether to decide for plant or livestock production is very difficult for agricultural manufacturers. Significance of the organic livestock production should not neglect. Many habits of manufacturers, information and the potential market, i.e. if they know to whom they are going to sell, influence the decision.

Chart 1. *Structure of plant production in 2013*¹⁵

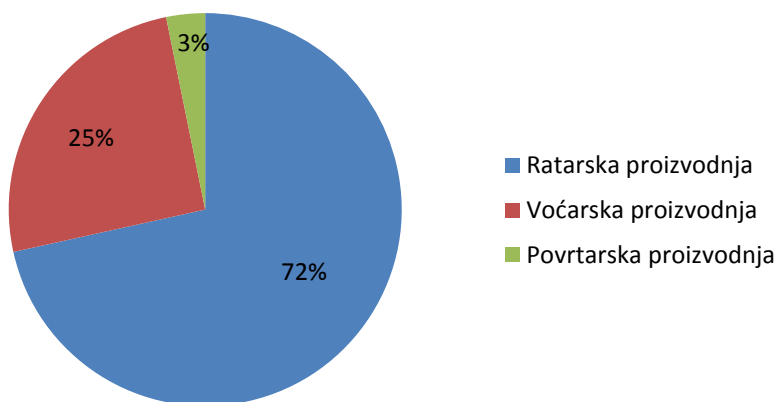

Finished product in agricultural production of plant products is a final phase of the production cycle with harvest or by picking fruits, while in livestock production this phase is a transitional phase in obtaining an organic product which fulfils conditions for certification.

Livestock organic production requires a different approach, completely encircled cycle of the organic fodder production without any antibiotics or GMO aiming to stimulate the growth or weight gain. In order to provide the complete certification of products in livestock organic production and determine the quality of these products, it is necessary for food manufactures in that holding to be completely controlled.

Such holding must have natural conditions both for the plant and livestock organic production. It means that land didn't use for the purpose of conventional production, that cattle have enough light, air and space

¹⁵<http://www.kombeg.org.rs/Slike/CeTranIRazvojTehnologija/2015/jun/Organska%20poljoprivreda%20u%20Srbiji%202014.pdf>, (14.09.2016.)

according to conditions and standardization of organic production. Period of convention in livestock production is also regulated with the legal framework. Thus, the convention period for cattle and horses of at least 12 months is regulated, for pigs and small ruminants at least 6 months, for milk-producing animals also 6 months, while for poultry this period is shorter (6-19 weeks).¹⁶It is important to mention that this convention period refers only to animals in livestock production, while regarding food that is essential for livestock grazing, the convention period has to start much earlier.

Chart 2. *Structure of livestock production in 2013*¹⁷

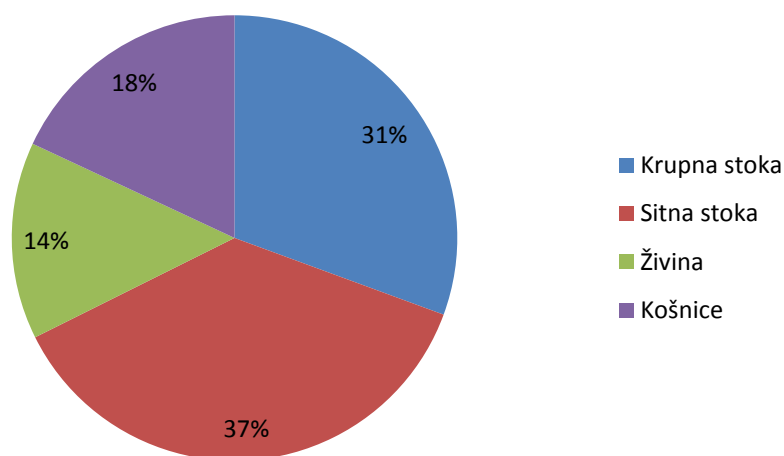

There are 35 ideal locations for the production of organic food in Serbia. These are Fruška Gora, Djerdap, Tara, Kopaonik, parts of mountain Šar, Prokletije, Kamaraš, Palić, Tikvara, Begeč pit, Vršac mountain, Ponjavica, Golija, Sićevac gorge, Stara mountain, Grmija, Subotica sandy terrain, Zobnatica, complex Panonija, gorge of the river Gradac, Raja, Rogot, gorge of the river Resava, Ovčar - Kablar gorge, Sokograd, Ozren meadows, Forest Park Ivlje, gorge of the river Mileševka, Miruša, valley of the river Pčinja, Avala, Kosmaj, Mokra Gora, Radan and Vlasina.¹⁸

¹⁶<http://www.agroservis.rs/organsko-stocarstvo>, (19.09.2016)

¹⁷All the same.

¹⁸<http://www.balkanmagazin.net/hrana/cid143-29444/svet-i-srbija-organska-poljoprivreda>, (14.09.2016.)

Demand for products of organic origin

Organic agricultural production in European Union countries is on a higher degree of development, which has been stimulated with greater financial investments in regard to our country.

Consequently, the supply of these products is greater, and the market, by its absorption power, is capable to accept quality but also more expensive healthy food. Growth rate of organic production in EU countries ranges from 8-10% on an annual basis, and in some countries this growth rate is even 25%. Besides the developed production, demand for these products is certainly much higher.

The awareness on organic production has developed for many years in these countries and therefore there is demand on the market which cannot be covered by own production, so often the products of organic origin and healthy food are imported.

The greatest need for organic products is noticed on markets in Germany, France, Italy, Great Britain, Austria and Switzerland, for plant organic products. The most wanted products are cereals, fruits and vegetables. Demand for livestock products of organic origin is extremely high and in expansion.

Promotion of organic products has substantially affected the awareness of consumers in EU. Supermarkets and bigger sales facilities, and not only specialized stores for healthy food, have led to this state. It is strictly taken care of certification, declaration and visibility of organic products at points of sale.

As the economic situation in EU countries differs from country to country, in that way also differ consumers' attitudes regarding healthy food. Development of organic food production doesn't have the same trend in all countries.

There is the satiation for organic products in Austria, the Netherlands, Spain, Denmark and Sweden, and therefore a percentage of organic production increase and values which these products realise by sale are lower than in previous years.

Table 4. *Review of organic products consumption in EU countries*

	Germany	Denmark	France	Great Britain	Italy
Milk and dairy products	15%	32%	15%	31%	18%
Fruits and vegetables	22%	23%	17%	23%	25%
Bread, flour and pastry	11%	15%	10%	N/A	7%
Eggs	5%	6%	6%	3%	8%
Baby food	5%	N/A	5%	8%	5%
Fresh meat	4%	6%	7%	5%	N/A
Poultry	N/A	N/A	7%	2%	N/A
Wine	N/A	N/A	10%	N/A	N/A
Beverages	11%	N/A	5%	8%	10%

Source: www.kombeg.org.rs

The EU member countries satisfy their own needs partly by import in which dominate fruits and vegetables. Grapes, apples, raspberries, blueberries and other berries import the most of all fruits. Of vegetables, carrot, onion, potato and tomato import the most. These products are available also out of season, when there are not much fresh products, and therefore their demand is relatively stable during the whole year. Livestock products import too, organic meat and milk, but the conditions for these products import are very strict, so a small number of manufacturers can satisfy these conditions.

Production and consumption of organic food of a plant and livestock origin in EU countries have the increasing significance and have the increasing share on the market. USA is although the biggest market of healthy food with substantial growth rates. Serbia, as a market, is not open for these products, primarily owing to a price which is 30% higher in regard to the conventional production products. However, we hope that the organic products have their consumers and this number will increase as the awareness on healthy food would be rising. Serbian chance is exactly in the production of plant/livestock organic products, not only in order to satisfy own needs, but also as a chance of our economy for export.

Characteristics of domestic market are very poor need and demand for these products, partly due to prices, but substantially as a consequence of consumers' habits. Availability of these products to customers affects it, insufficient promotion of healthy food, under development of distributive centre, etc. The system of specialized stores is not developed and big supermarkets don't have a satisfactory level of these products sales.

As the imperfection of our market we can find the assortment of organic products, which cannot compare with the products in conventional production. As we observe a vertical assortment structure, we can conclude that there are very few fresh products in supply. The processed products like juices, jams and other food provisions for winter are mostly offered. Vegetables and cereals, and less fruits, can be found in a horizontal structure of supply. In stores, visited by many people on daily bases, there mostly the processed products are offered, while fresh products are few. Products of livestock organic production which can be found on our market are mainly eggs and honey, and just from recently milk, yoghurt and sour cream.

Agricultural manufacturer in Serbia commit himself for the organic production only if he has a known buyer for the reason of lack of financial resources and certainty in selling. Manufacturers are often encouraged by buyers who help them with their share in investments, knowledge and the use of modern technological solutions, which are difficult to reach by our agricultural manufacturers. Buyers' interest is in a large margin which they achieve on the market or if they have their own processing and storing capacities, which is a special problem to store the organic products, and based on it, to sell these products out of season after even several times bigger price.

The awareness of inhabitants on healthy life, which implies also healthy diet but not as a pharmaceutical trick, should be surely raised to a higher level. The state plays a very important and obligatory role. The state can stimulate agricultural manufacturers to such production by different projects, subsidies and other incentives. This will surely reflect on a foreign trade balance, by increasing export a surplus, with natural resources we have, will be accomplished.

With the correct strategy, the way to final consumers will be found, whether it is about domestic or foreign market. Projects such as *The Organic Food Green Market*, which was first held in Belgrade in the year

2011, have shown good results and every interested and potential consumers could visit the market and could assure the quality of these products.

Role of government in stimulating and realising the organic production

Conditions for the organic food production are very harsh and demanding and the certification of products is regulated by a legal framework, as in those countries in which organic food is produced, as well as in international regulations. The Organic International Action Group (IFOAM) has issued the regulations and conditions for the production of organic food:

- Isolation of plot or farm in which the production of organic food is planned,
- Constant development of technology and knowledge, professional control and managing of production,
- Adjustment of plant and livestock organic production.

The state role in forming the healthy and correct organic food production is important not only in a financial sense, but also in legal-regulatory sense. The conventional way of production went to the other extreme, and in order to make higher incomes, various agro-chemicals have been used, the natural land characteristics have been disrupted and many scandals regarding the food quality and safety have appeared.¹⁹

Once polluted land cannot be used for the production of organic food; incidents of various diseases like a mad cow disease (BSE), foot-and-mouth disease and increasing genetically modified food (GMO); these are all factors which have an influence on the increase of demand for the organic food products. Increase in demand for healthy food appears owing to health reasons (46%) and owing to a better taste (around 40%). Needs for organic products have brought to this production growth up to 20% annually in USA, France, Japan and other high-developed countries, since many their needs have been satisfied by import.

¹⁹Cvijanović, D., Simonović, Z., i Mihailović, B. (2011). *The Common Agricultural Policy in the function of organic production development in EU*, International Conference „European Union Food Sector after the last enlargements – conclusion for the future CAP“, Rajgrad, 14-16. Juni 2011.god. No 6.1. datum, Warsaw, Poland, pp. 62-79.[ISBN 978-83-7658-134-7]

World Health Organization (WHO) informed that around 3 million people annually are being poisoned by food with traces of pesticides in it. Healthy food opportunists state that a price is extremely high and don't take into consideration the health costs for treating the patients from diseases caused by consuming agro-chemicals, as well as costs regarding the natural sources purification. Only in Great Britain 2.34 milliard pounds set aside for costs in treating, or for arable land 208 pounds/ha. Around 120 million pounds set aside for environmental preservation. Not taking into consideration posttraumatic effects, emotional and physical problems, the BSE disease has cost around 4.5 milliard pounds. Environment due to intensive food production is exposed to various chemical agents, and there anticipates that this land won't be for the production of organic food in next 50-100 years. This erosion means high costs in maintaining the natural features.

Organically manufactured food doesn't contain any chemicals, pesticides or other artificial admixtures. Long-term research conducted in Germany and USA showed a high attendance of oligominerals: potassium, iron, magnesium, phosphorus and vitamin C. For now, the best position regarding the development of organic production has Denmark, where 25% of total arable land makes the certified organic agriculture.²⁰

Certification of organic products – due to everything mentioned above, the organic production has to be controlled in every phase of production, and every product should be certified. The certification is regulated by the International Federation for Organic Production (IFOAM), the regulations of European Union and Codex Alimentarius, i.e. individual national legal regulatory rules. Certified organic product in Serbia implies the following steps:

- Registration, verification of contracts with a house authorized for certification,
- Requirement, submitting the fulfilled forms for certification,
- Adopting a plan of inspection, calculation of the certification costs and instructing an agricultural manufacturer what actions should take in order to certify easier,
- Adopting a conversion plan for next three years, the determination of production technology, control and evaluation of products,

²⁰<http://siepa.gov.rs/sr/index/standardi/organic-sertifikat.html>, (19.09.2016),

- Evaluation means appraisal and provides the certification, with possibility of correction, rectification of deficiencies in order to improve production,
- At the end of certification process, according to evaluation (appraisal) there makes a decision on issuing the certificates. The decision is a certified letter in which is defined for which season, which product and in which extent a manufacturer gets the certificate, an approval that he can sell a product as an organic product.²¹

Supervision of organic production includes numerous procedures or controls, and some of them are: control of the conditions fulfilment for starting the organic production, control of the inclusion of land plots, i.e. livestock production into the organic production, control of technological processes, packaging, transport and storage and other controls according to the law. In case when the designation of products by the designation „organic product“ is disrespected, i.e. when there is no adequate certificate for it, or the designation is done before the certification is issued, a fine ranges from 100,000 to 300,000 RSD.

The certificate should include: name, location and a number of code of an authorised organisation; name, address or location of a manufacturer; type of an organic product and its evaluated quantity for one year; number of certificates; stamp of an authorised organisation and a signature of an authorised person in that organisation. In our country, the organic products are designated with „organic product“, while products obtained during conversion designate with „product from the period of conversion“. During the promotion of an organic product, it is not permitted to quote if it is about a top-quality product only for the reason it is produced of organic compounds or in accordance with the organic production standards. During export or transport of organic products, quality must be harmonized with a declaration or a label. As regards the declaration, it must include: name of a manufacturer, i.e. name of an importer in international trade, a country of origin, a year of production, an expiration date, as well as a number and date of issuing certificates.

²¹Babović, J.,(2008),*Agrobiznis u organskoj proizvodnji*, University Business Acedemy, Novi Sad, p 15

Table 5. *Authorised organizations for issuing certificates*

ORGANIZATION	WEB PAGE
Ecovivendi	www.ecovivendi.rs
Etko Panonija	www.etkopanonija.org
Ecocert Balkan Beograd	www.ecocert.com
TMS CEE	www.tms.rs
Control Union Danube	www.control-union-danube.ls.rs
Centar za ispitivanje namirnica	www.cin.co.rs
OrganicControlSystem	www.organica.rs

Source: *Authors*

Certification of products should provide to buyers at all times the accurate information on products regarding:

- ✓ That less than 95% of this product's compounds are organic,
- ✓ That products are harmonised with the inspection regulations,
- ✓ That products come directly from manufacturers and packed in adequate packaging,
- ✓ Those products contain a manufacturer's name, a code and a body which performed the inspection.

Legal framework – First regulatory framework in Serbia was given by the Law on Organic Production in the year 2000 (Official Gazette SRY no. 28/2000) passed by the Federal Ministry of Agriculture, by which was anticipated the determination of plant and livestock production methods, keeping a register of manufacturers as well as the organic production register, contents of a form which has to be submitted in order to get the certificate.

With the cancellation of the Federal Ministry of Agriculture, competences were surpassed to the Republic Ministry, so in the year 2006 a new Law on Organic Production and Organic Products was passed. In regard that the Law on Organic Production and Organic Products hasn't been successful in managing the sector of organic production and in regard that the new regulations for organic production have come into force in EU, a new Law on Organic Production („Official Gazette RS“ no. 30/10) was done through the project TAIEX, prepared in accordance with the Council Regulation (EC) No.834/07 and the Commission Regulation (EC) No.889/08. The law was adopted in May 2010, and its application started from 1st January 2011.

Risks of organic production

If we succeed in analysing the situation in the agricultural production activity and drawn conclusions from the existing analysis, as in world as well as in domestic framework, we can rightly conclude what are the risks and what are the possibilities for organic agricultural production in Serbia.

Those products obtained by the conventional food production are full of chemical admixtures. According to a report of the British Ministry of Agriculture (MAFF), there are a great percentage of residues from artificial fertilizers and protection agents in food we consume every day. According to data of UK's Health and Safety Executive, 5% of people who are in contact with pesticides search for their help in the centre, while there are still 10% more of people with milder symptoms of pesticides poisoning who don't go to the doctor. Research at the University of North Carolina shows that, women who were in the vicinity of fields on which pesticides were applied, were increased the risk from spontaneous abortion for 40-120% due to foetus deformation. Presence of pesticides, which active matter is Dieldrin, increases double the chance for breast cancer development, as it was proved in Denmark.²²

When it comes to an activity which aims to generate income, making new values, products which sell on the market and in that way generates income, and along with the investments that make the expenditures or inputs of this process, we can classify the risks:

- Operational,
- Financial,
- Market.

Operational risks are a lack of inputs, knowledge, equipment and labour as an important element of such production and manufacturers' organization. What distinguishes the organic production from the conventional one is the presence of a large number of pests, such as rodents and some other species that feed on plants, as well as plant diseases which cannot be controlled with pesticides. Diseases are the risk that affects both plant and livestock organic production. Spreading weeds and the impossibility to prevent them by chemical agents is also threat to the organic production crops.

²²https://www.google.rs/search?q=skripta+o+organskoj+proizvodnji+hrane&ie=utf-8&oe=utf-8&gws_rd=cr&ei=kcjfV4qPHcHWa5fSqfgE, (19.09.2016)

Theft is the risk which appears in all production processes and especially regarding products of higher value. The sensitivity of organic products becomes prominent in the conditions of inadequate transport and storage. Food is extremely sensitive, especially the organic food which has no preservatives or any other protection agents which can protect from fast, but natural loss of features and thereby the loss of quality.²³

Table 6. *Review of operational risks of the organic food production*²⁴

OPERATIONAL RISKS	PROPOSED SOLUTIONS
Extreme weather conditions	Application of protective measures in case of natural and anthropogenic negative incidents, insurance as one of the most important measures
Lack of technical infrastructure, consulting, inputs market – equipment, seed, plant protection agents	International projects, regional associations, cooperation with domestic manufacturers
Diseases and pests	Protection in accordance with the organic production regulations, insurance
Weed	Cleaning up weed in accordance with the organic production regulations, insurance
Theft	Surveillance systems in open and closed space, physical-technical security, insurance
Decline in quality due to lack of storehouses	Adequate selection of storehouses, control of terms in them, quality monitoring of storage products and continuity
Decline in quality due to transportation of organic products	Providing adequate means of transport, their control and respecting the time necessary for transport
Damaging products due to an inadequate process of export	Documentary evidence on products in form of a contract by which is possible to prove the responsibility in case of some problems appearance, in order to sustain the credibility on the market and further business

²³Mihailović, B., Cvijanović, D., Gnjatović D., (2016), *Agrotehnička opremljenost i skladišni kapaciteti u funkciji razvoja voćarsko-vinogradarske proizvodnje u Smederevu*, XXI MEETING ON BIOTECHNOLOGY with international participation, Čačak, 11th-12th March 2016, Proceedings, Vol. 21.(23), 2016. CIP 63(082); 60(082); ISBN 978-86-87611-40-5; ISBN 978-86-87611-42-9 (series); COBISS.SR-ID 221885196; pp. 295-300.

²⁴Radović, V.,(2014), *Rizici u organskoj poljoprivredi*, Univerzitet Educons, Sremska Kamenica, p 128. Mihailović, B., Cvijanović, D., Gnjatović D., (2016), *Agrotehnička opremljenost i skladišni kapaciteti u funkciji razvoja voćarsko-vinogradarske proizvodnje u Smederevu*, XXI MEETING ON BIOTECHNOLOGY with international participation, Čačak, 11th-12th March 2016, Proceedings, Vol. 21.(23), 2016; pp. 295-300

²⁴Radović, V.,(2014) *Rizici u organskoj poljoprivredi*, University Educons, Sremska Kamenica, p 128

All these incidents, which can have harmful effects to products of organic origin, have their alternatives as it is shown in Table 6, in Proposed Solutions.

Table 7. *Review of financial risks of the organic food production*²⁵

FINANCIAL RISKS	PROPOSED SOLUTIONS
Non-payment by buyers	Inclusion of manufacturers organizations into the process of negotiation and adequate institutional protection
Insufficient gain for covering the production costs	Increase of the production efficiency, decrease of costs by products unit
Unfavourable loans for agricultural manufacturers	Joining in order to joint venture, great support aiming to protect by subsidized loans
Insufficient subsidies by government or their complete or partial elimination	Planning based on own resources (equity) in order to avoid the risk of unexpected political changes of decision-makers, joint ventures of manufacturers
Late payments to manufacturers for taken over products	Adoption of legislation by which a debtor-creditor relationship is arranged

Financial risks that appear in situations when there is a lack of resources to start the production, the purchase of inputs and a lack of income to cover costs. Unfavourable loans for the economy, lack of subsidies by government, as well as non-payment by debtors are the causes to these incidents.

These incidents also have the alternative solutions, which can be seen in the column two, Proposed Solutions. Impact of the state is very important and many solutions and alternatives are the result of the state and its institutions' efforts to make better conditions for agricultural manufacturers.

Every market risk refers to the existence of demand for the specific products, which is a very important factor for the organic products of a higher price range. Countries with a better standard of living will surely have increasing demand for these products. The existence of competition is also considered as one of the market elements and if it is unfair and extremely strong, it may pose a risk to every manufacturer and tradesman.

²⁵All the same.

The important thing regarding the organic production is the law regulation, as alternative to legal risks. Keeping strict records of manufacturers, respecting all norms in the organic food production, issuing certificates with the existence of strict rules which must be respected, with a permanent and harsh control along with serious punitive consequences for frauds and other illegal actions would regulate the market substantially and create the seriousness for manufacturers on realistic economic indicators. Such regulatory rules would help those who are serious and operate fairly to sell easier on foreign markets, which would have the favourable effects on foreign trade balance of a state.

Table 8. *Review of market risks of the organic food production*²⁶

MARKET RISKS	PROPOSED SOLUTIONS
No requirements for the specific products or they are drastically reduced	Diversity of products in order to avoid loss and establish the possibility to sell on other markets
Mismanagement of signed contracts by contractors on various grounds	Initiate a judicial proceeding in order to execute rights and obligations from a contract
Competition offering products at lower prices	Association of agricultural manufacturers into clusters and providing an adequate agreement among the key actors – a buyer and a seller
Unexpected increase of prices on the market	Negotiating a price in order to find mutual, satisfying solution
Reduction of the purchasing power of consumers	Offer a minimum acceptable price by which could cover all costs and achieve a minimum wages, or processing of products in order to achieve continuity in earnings
Exchange differences	Cautiousness in calculation, assuming that there will be higher exchange differences. Continuous monitoring of a current state of macro-economic situation in the country.

²⁶All the same.

Conclusion

Agricultural production is an important economic branch and it has the increasing significance owing to the increase of the planet's population, which directly affects the increase of demand for food. A man, chasing to produce large quantities of food, has forgotten at one point about his health, so he had achieved to realise great efficiency in food production by using the great achievements of chemistry and other sciences. Owing to the occurrence of various diseases, increasing the health protection costs, as well as environmental pollution, we become aware of a fact that, after all, there should turn to natural resources and to direct the production of food to the healthy food production. The question is whether it is payable and sufficient form of production for satisfying the increasing needs, along with the decreased potential of agricultural land.

Many countries with adequate agricultural potential see their chance in the production of healthy food and export-oriented production. Quality ensured by the organic agricultural production is immeasurably better in regard to conventional production. Besides, the advantage is in environmental protection and Serbia has favourable climatic conditions, enough agricultural areas for cultivation, a positive public attitude and the intention of manufacturers to orient toward the organic production.

Potential of the organic production in Serbia can also be searched in insufficient engagement of government, incentives to manufacturers which haven't been expressed until now. All the weaknesses that we recognize we can use in the future as a power and in that way turn disadvantages such as the lack of national concern on health, poor legislation, bad marketing, insufficient demand for healthy food, consumers awareness and other disadvantages into advantages.

These are all chances which can be used if we commit ourselves seriously to work. Strong production could be created by the diversification of products, parallel development of plant and livestock organic production, association of agricultural manufacturers and by continuing education.

There is still sufficient arable, but unused land in Serbia, and therefore we can think about the organic production development. There surely is the risk of commitment and it is in outcome of this process, economic result, proper use and the observation of international standards and the organic production norms, by continuous monitoring of achievements and their

application. One of threats is spreading of weeds, the case of ambrosia, which jeopardizes human habitats and health. Likewise, the closeness of plots with the conventional way of production offers a chance for transferring pollen from these plots.

Literature

1. Babović, J.,(2008), *Agrobiznis u organskoj proizvodnji*, Privredna Akademija, Novi Sad.
2. Birovljev, J., Vojinović, Ž., Balaban, M.,(2015), *Potencijal poljoprivredne proizvodnje i uticaj na premiju osiguranja*, Ekonomika Poljoprivrede, Beograd, ISSN 0352-3462.
3. Cvijanović, D., Simonović, Z., Mihailović, B. (2011). *The Common Agricultural Policy in the function of organic production development in EU*, International Conference „European Union Food Sector after the last enlargements – conclusion for the future CAP“, Rajgrad, 14-16. Juni 2011.god. No 6.1. datum, Warsaw, Poland, pp. 62-79.[ISBN 978-83-7658-134-7]
4. Cvijanović Gorica, Cvijanović, D. i Dozet Gordana. (2013). *Menadžment u organskoj biljnoj proizvodnji*, Institut za ekonomiku poljoprivrede, Beograd. ukupno 366 strana.CIP 631.147. ISBN 978-86-6269-020-3. COBISS.SR-ID 197065740.
5. Ivanović, M., Ivanović, B.,(2016), *Šanse i prepreke za razvoj organske proizvodnje u Srbiji*, Poljoprivredni fakultet u Beogradu.
6. Mihailović, B., Cvijanović, D., Gnjatović, d., (2016). *Agrotehnička opremljenost i skladišni kapaciteti u funkciji razvoja voćarsko-vinogradarske proizvodnje u Smederevu*, XXI SAVETOVANJE O BIOTEHNOLOGIJI sa međunarodnim učešćem, Čačak, 11-12. Mart 2016.godine, Zbornik radova, Vol. 21.(23), 2016. CIP 63(082); 60(082); ISBN 978-86-87611-40-5; ISBN 978-86-87611-42-9 (niz); COBISS.SR-ID 221885196; str. 295-300.

7. Radović, V.,(2014) *Rizici u organskoj poljoprivredi*, Univerzitet Educons, Sremska Kamenica.
8. Simić, I., (2015), *Organska proizvodnja-neiskorišćen potencijal Republike Srbije*, Support Programme Strengthening Civil Society, Norwegian Embassy.

Internet source:

1. [http://www.kombeg.org.rs/Slike/CeTranIRazvojTehnologija/2015/jun/Organska%20poljoprivreda%20u%20Srbiji%](http://www.kombeg.org.rs/Slike/CeTranIRazvojTehnologija/2015/jun/Organska%20poljoprivreda%20u%20Srbiji%20)
2. <http://www.poljoprivreda.infohttp://poljoprivreda.info/?id=723&oid=25%3Fref=Guzels.TV>
3. <http://www.europeanpolicy.org.dokumentacioni-centar>
4. <http://www.tehnologijahrane.com/enciklopedija/organska-hrana>
5. http://www.kombeg.org.rs/aktivnosti/zadruzni_savez/Detaljnije.aspx?veza=326
6. <http://www.agroservis.rs/organsko-stocarstvo>
7. <http://www.balkanmagazin.net/hrana/cid143-29444/svet-i-srbija-organska-poljoprivreda>
8. <http://siepa.gov.rs/sr/index/standardi/organic-sertifikat.html>
9. https://www.google.rs/search?q=skripta+o+organskoj+proizvodnji+hrane&ie=utf-8&oe=utf-8&gws_rd=cr&ei=kcjfV4qPHcHWa5fSqfgE

II SECTION

OPTIMIZATION OF AGRICULTURAL PRODUCTION, IMPROVEMENT OF QUALITY AND PRODUCT REALIZATION

LAND MANAGEMENT IN MODERN FARM PRODUCTION

Boris Kuzman¹, Radivoj Prodanovic²

Abstract

The food is a basic human need, and as agricultural land is the base for its production, it is considered as the most important category of land. Land management in modern farm production is the key element of agricultural, economic and social development.

The aim of paper is to actualize the issue of the rational agricultural land management, as well as defining the directives, which will help efficiently to use and preserve the most important resource for future generations.

Of the methods that are applied, the key are statistical methods, graphical methods, comparative analysis method, and other standard methods are used (analysis and synthesis, description, logic, etc.)

One of the most important assignments is determining the availability and the state of land capacity, while in order to establish the most adequate management models is important the determining the ownership structure, the size of the property, way of the use and degree of utilization. Law on Agricultural Land is the key of advancement of land management from the macro aspect.

The importance of long-term sustainability and advancement of land management have been recognized by the individual producers, and it is important that state recognizes in them its the most significant strategic partner.

Key words: *land management, farm production, sustainability*

¹Boris Kuzman, Ph.D., Associate Professor, Institute of Agricultural Economics, Volgina Street no. 15, 11 060 Belgrade, Serbia, Phone: +381 63 590 129, E-mail: kuzmanboris@yahoo.com

²Radivoj Prodanovic, Ph.D., Docent, University Business Academy in Novi Sad, Faculty of Economics and Engineering Management in Novi Sad, Cvecarska Street no. 2, 21 000 Novi Sad, Serbia, Phone: +381 21 400 484, E-mail: rprodanovic@fimek.edu.rs

Introduction

One of the primary resources, which determine the sovereignty degree of some country, is food. The significance of food is constantly increasing in the world, regarding the growth of population and decreasing resources for production. As the agricultural land presents the base for its production, simultaneously, it presents, productively and economically, the most important land category, as a natural resource (Sevarlic, 2015).

Land management in modern farm production forces upon as a one of the most important issues of agricultural production, but also society in whole. The Republic of Serbia disposes with (although in the last half century significantly reduced) significant land resources and their adequate valorization is the holder of complete agricultural production advancement, similar economic activities and striking more significant position in the liberalized world food market.

The Subject of Paper

The subject of paper is modeling the land management in modern farm production, as something of national interest with strategic importance.

All important aspects of farm land management from micro and macro aspects are included with emphasis on sustainability, as a basic parameter which determines success in the long-term.

The Aim and Importance of Paper

The aim of work is to actualize the issue of rational agricultural land management, as well as defining the directives, which will help efficiently to use and preserve the most important resource from various adverse impacts, so that generations, that are coming, could have possibilities for production of quality food in sufficient quantities.

The importance of the paper is reflected in the consideration and connecting the necessary conditions which are needed for rational land management in modern farm production in the long term- as the only way of creating the sustainability of the system.

Methodology

In research, it is used description method, statistical method, graphical method, methods of induction and deduction, comparative analysis and synthesis methods, generalization and abstraction, logical methods.

Land Use in Modern Farm Production

Farm land is the elementary resource, which provide the production of all agricultural products, even cattle, because it depends on land for production of forage (Kay et al., 2012).

During recent 300 years, significant expansion and intensification of farm production are recorded on earth. In the period from the 19th century, major changing in the intensity degree are perceived, where surely the transport revolution should be marked as one of the valuable determiners of development and intensification of agricultural land use (Rankin, 2009).

The land is not just the primary production factor, but also the basis of food security of the population and the most valuable natural resource from which crucially depends the development of rural communities and the survival of rural families (Subic et al., 2005).

Contemporary Serbian agriculture is characterized by trends of insufficient investment, which results with the much weaker results comparing to the possible, insufficient utilization of potential, accelerated deagrarianization, huge number of elderly agricultural households, and low level of specialization in production, low average earnings and thus, insufficient motivation. Serbian farm production is characterized by domination of individual agricultural holdings, the relatively small size of land area (4.5 ha), large fracturing, but also lack of agricultural cooperative and inter-cooperative connection (Census of Agriculture, 2012-I; Bozic et al., 2004; Parausic et al., 2007).

Status and Tendency of the Land Availability in the World

The world's land area is 13.2 milliard acres. There from, crop plants are fostered on 12% of the land, 28% is covered by forest, 35% covers systems of pasture and forest ecosystems, while the rest 25% is covered by the rest land (FAO, 2011).

Figure 1. World Land Areas by Territories

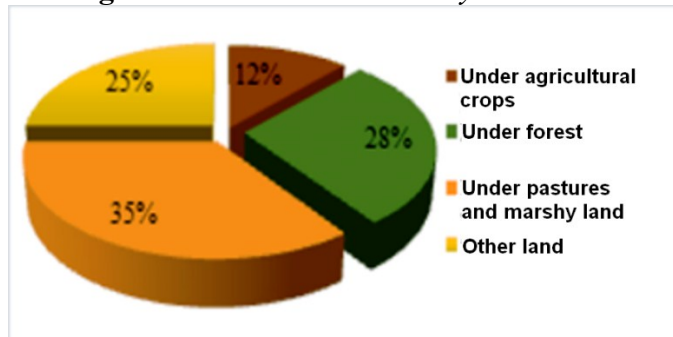

Source: FAO, 2011

The world arable lands are increased by 12% over the last 50 years, mainly because of forests, wetlands and grasslands, while the world regions under irrigation have been doubled.

With a goal to assess the global impacts of land use on the environment and the provision appropriate countermeasures, the group of researches has created a map of system of land use at the global level (Figure 2), where the 12 archetypes have been identified, based on numerous parameters (Helmholtz Centre For Environmental Research-UFZ, 2013).

Figure 2. Systems of Archetypes of Land Use: World Map

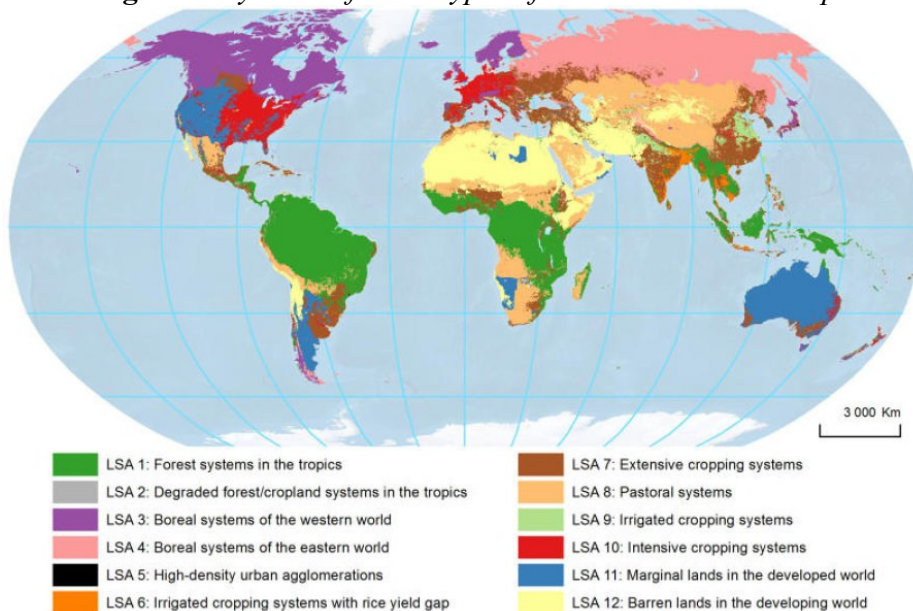

Source: Helmholtz Centre For Environmental Research, 2013

The importance of these researches is reflected in:

- Identification where the unused potential for intensification of farm production is;
- Coordination of the potential of intensification with interests of environment;
- Coordination of potential with socio-economic conditions.

Agricultural Land Status in Republic of Serbia

Disposition of the relevant information presents the starting point of status analysis and tendency of availability in Serbia. Considering that we disposed until 2012 with Census of Agriculture from 1960, Census of Agriculture 2012 presents nationally the most significant and programming the most comprehensive activity. Relatively high methodological and statistical comparability with the definitions and databases in relation to FAOSTAT³ and EUROSTAT⁴ is of great importance for the comparability of the situation, determining the development strategy, as well as the opportunity of positioning Serbian agriculture on a global scale (Sevarlic, 2014).

The Census of Agriculture (2012), following facts are identified:

- In period from 1960-2012, the third of the total agricultural land was spent (over 1.9 million ha) on infrastructure and other non-agrarian purposes, and the estimated economic damage is around 10 milliard euros.
- Total available land covers 68.9% of territory whose structure is made of: 72.2% of agricultural land, 19.1% forest land and other land 8.6%.
- The land suitable for agricultural production makes only: 52.2%, while 47.8% makes the class of land with limited or very limited production capacity (5% in Vojvodina and 95% in Central Serbia).

Structure of farms in Serbia is very complex, where small farms parallel exist, subsistence farms, huge family farms, as privatized large enterprises with mixed ownership structure. Decreasing trend of Serbia's agricultural farms is present (Bozic et al., 2004).

³The Statistics Division of the FAO.

⁴The Statistical Office of the European Union.

Average size of farms in Serbia accounts 4.5 hectares, while in area of Vojvodina, that size is over 10 ha. In ownership structure of farms in Serbia, depicted in Figure 2, small farms (up to 5 ha) have the largest share in total number of farms with 48.8%, while the biggest farms are only 1% of total number of farms.

Figure 3. Owned Farm Structure

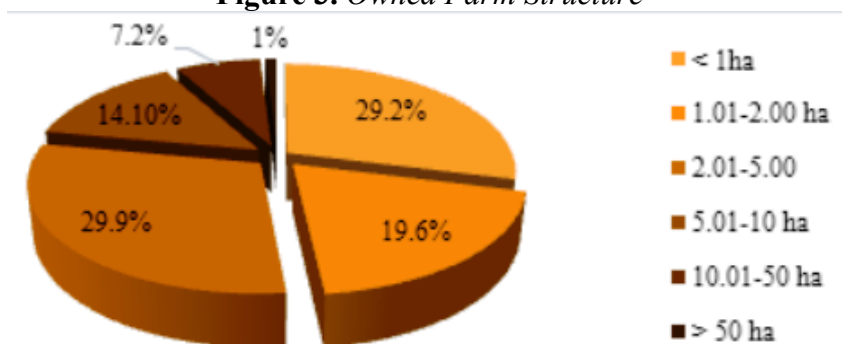

Source: *Census of Agriculture (2012)*

Family farms are very fragmented, they have conspicuous natural consumption and significantly lower degree of commercialization in comparing with European farms (Bozic et al., 2004). By the Census of Agriculture (2012), it is identified that unused agricultural land includes 12.3%, which certainly is a fact that indicates to the need of arranging that land surface. In total property, own land is dominant (Figure 4).

Figure 4. Share of Own Land in Total

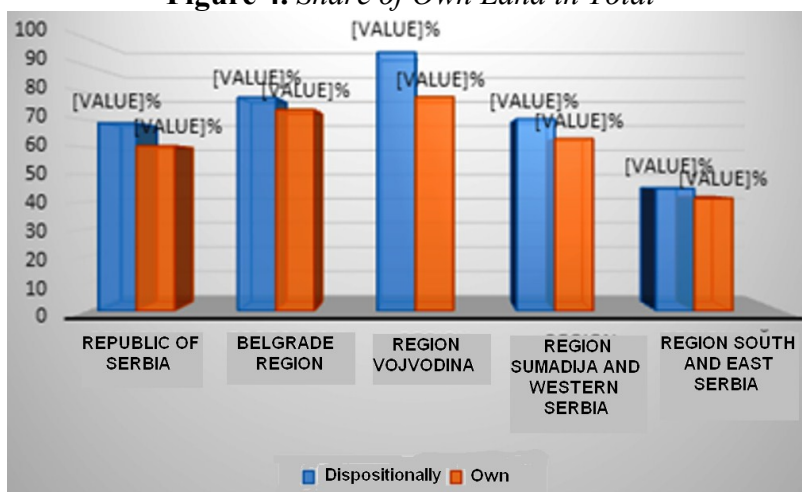

Source: *Census of Agriculture (2012)*

According to data RZS (Cvijanovic et al., 2014), analysis of economic size of agricultural economy in Serbia is conducted, thus it is identified that average economic size accounts 5.939 euros in 2012, and it is mostly determined by large number of family farms, while according to organizational and legal form, this indicator is:

- 1) in sector of family farms - 4.990 euros;
- 2) in sector of legal entities and entrepreneurs - 204.755 euros.

Observed to regions, smaller economic size of farms is in region of South and East Serbia, region of Sumadija and West Serbia, while the stronger economic farms are located in Vojvodina (Figure 5).

Figure 5. *Average Economic Size of Farm by Regions*

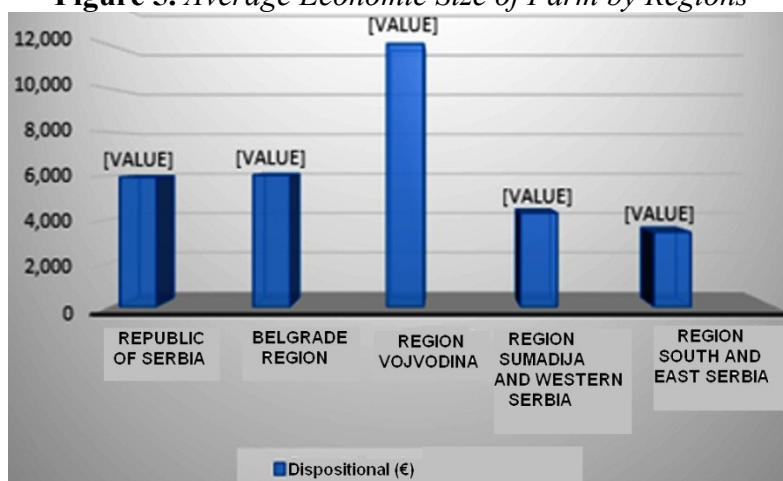

Source: *Census of Agriculture (2012); Cvijanovic et al., 2014.*

High participation of population in rural areas and availability of capacity of agricultural land should be the framework of national plan of land management in order to advance complete agricultural sector, and by that increase existing participation of agriculture in gross domestic product (GDP).

Land Management

The land characteristics greatly affect the economy and management by it. The aim of farm land management is to keep its productivity, and if it is possible to improve it. The land could be made inappropriate for agricultural production, if it is not rationally used, and due to floods, erosion and other disasters (Kay et al., 2012).

The population growth and need for food, deagrarization, globalization of agricultural production and market liberalization have caused the necessity of agriculture development, as well as the farm production directed to achieve increasing productivity. By time, conventional access has completely taken over irresponsibly imposing inadequate solutions for numerous issues such as: (1) need for increased use of land; (2) necessity of irrigation; (3) increased need of mineral fertilizers and pesticides; (4) development of highly income models of farm production; (5) secure modification of plants and animals, in order to increase productivity. Sustainability of the entire agricultural system is threatened by solutions which are offered by conventional approach, and which is still dominant today.

The consequences of conventional approach to the agricultural activity and land management are numerous and are reflected in infringed its quality and productivity, which can imply serious environmental and social problems.

Land management is the key issue of sustainability of farm production, satisfying various needs of society, preservation of genetic heritage and degraded ecosystems.

Land management represents systematic assessment:

- Land and water resources,
- Alternative for land use,
- Economic and social conditions with aim of choice and adoption the best options of land use.

At the same time, land management presents planning the farm production in such a level that includes both benefits for farmers and whole community.

The process of land management defines what is considered as the best use for particular plan project. Planning process starts with establishing the aims and project assignments, then there are work organization, problem analysis, identification of possibility for changes, assessment of sustainability of land, evaluation of alternatives, the choice of the best option, plan preparation of land use, plan implementation, as well as monitoring and audit of plan (FAO, 1996).

The aims of planning of land use are efficiency, equity, acceptability, and sustainability. The agricultural land management is determined by combination of techniques criteria, farmers knowledge and economic principles e.g. profitability (Verheye, 2011).

For farmers, efficiency is the largest return of invested funds that are invested in the form of capital and labor or the greatest possible benefit of available land, while the aims for the state are much more complex.

The plan preparation of land use (Scheme 1) is a complex process which requires primarily to determine what factors are the need (national objectives, land, people) and what the operational factors are available (schedule, training, budget, methods). By identification of needs, we decide whether the plan of land use will be adequate and sustainable. Therefore, it is necessary primarily to dispose with timely and comprehensive information, otherwise, inadequate identification is surely certain, and as such, represents the biggest “brake” of plan success. By collected data, database is formed based on which the analysis is preformed. The reports of conducted analysis make the base for creating the plan of land use, thus it is necessary to include them into the database, in order to follow results in a long-term level.

Scheme 1. *Plan Preparation for Land Use*

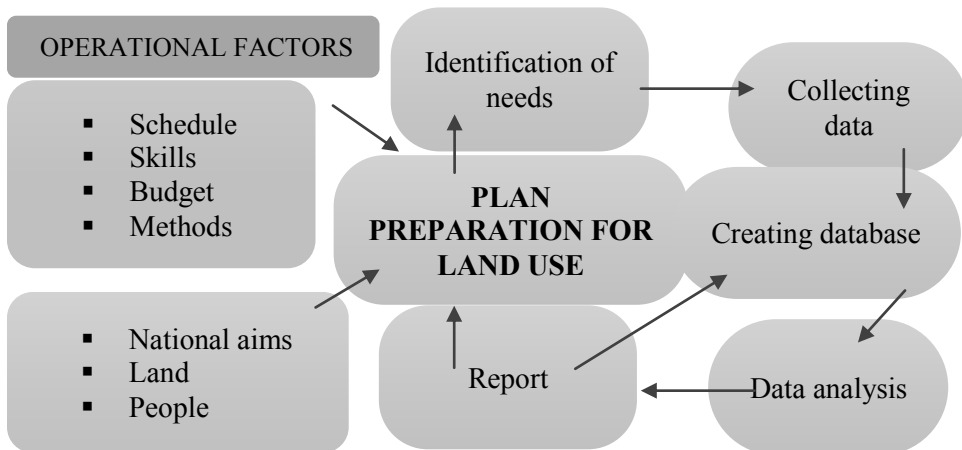

Source: *FAO, 1996*

In order to achieve synchronization of the planning land management, it is necessary to be applied at three levels: national, regional and local.

Land use planning at the national level starts with establishing the priorities at the regional level and includes: balanced policy of management with different sectors, which have competitive requirements for land, national developmental plan and budget, as well as the laws that regulate the areas as the lease of land, water resources, deforestation etc.

Considering that agricultural land presents natural resource of national importance, the Law on Agricultural Land presents one of the most important laws for managing the agricultural policy. It will contribute to the planning management of land in long-term, and should protect:

- farm land from irresponsible management solely for the aim of gaining profit,
- farm producers,
- complete agricultural activities.

As the most important aspects that could be regulated by the Law on Agricultural land, we exclude:

- Carefully regulating the conditions of land sale to foreigners, whereby normalizing the rigorous conditions of purchase plays a significant role. The conditions should be related to the necessity of previous long residence in the country, but also to the necessity of registered long engaging with farm production.
- Regulating in area of acquisition of ownership right in the long-term lease (lease of state land, equal access to the same, pre-emptive rights, etc.) It is unfavorably to allow the priority right to lease on long period, exclusively based on investment, because in that way the family farms are put in the unfortunate situation comparing to great investors. Precisely because the state of Serbia disposes with almost half a million hectares of land, it has an instrument by which it can provide competitive capabilities of small and medium-sized farmers.
- Regulating the maintenance of soil fertility by the tenants, by which the all would be conditioned by obligation to return the land's same or greater fertility after the expiry of the lease.
- Regulating the issue of obligatory land use. Enabling the access to the land that was not used for production for certain number of years to the persons who want to be engaged in the same, with unchanged ownership of the land with the consent of the amenable services.
- Regulating providing unemployed agricultural experts to advance significantly the agricultural production by self-employment on state land.
- Expansion of land ownership aimed to achieve economics of scale.

- Development of organic agriculture.
- Retention and return of population to the mountains area by exemption of tax of al agricultural lands above 600m, as well as land of V-VIII class.

The regional planning level of land use has a task to take across the national developmental plan on the local level, so that the same will coordinate with the diversities of land and its suitability for the purposes of project.

The essence of planning of land use on local level is the aims implementation of developmental national plan. On the local level, it is identified what is necessary to do, how, where, when, who, and on what ways it takes responsibility. Implementation of local developmental plan largely relies on individual farm producers, so the state should recognize in them the most important partner. Acceptability and applicability of plan on local level are the key element of national plan success.

Essentially, plan concept of land use presents bi-directional relations between planning on various levels (Scheme 2).

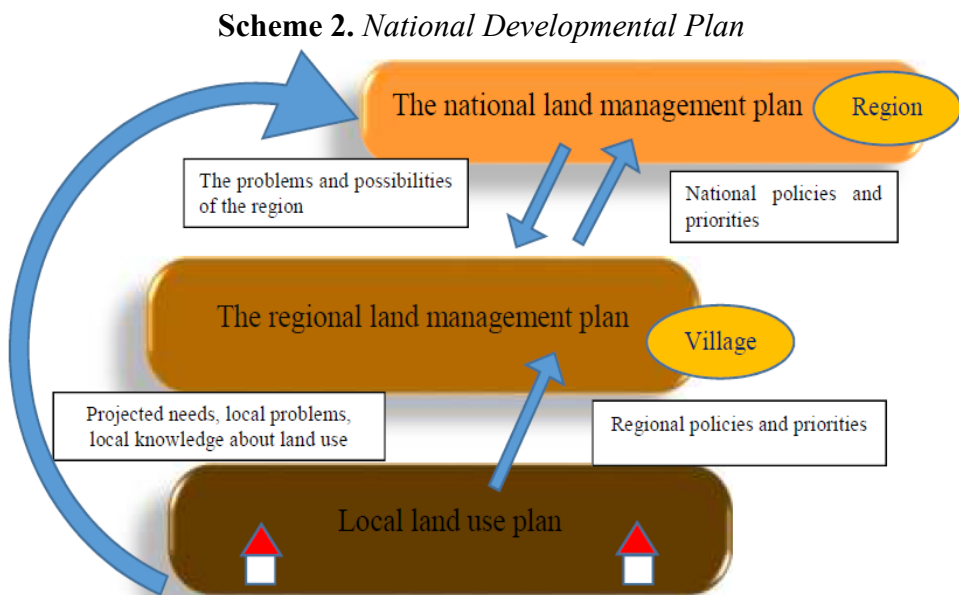

Source: FAO, 2011

The Ways of Providing Agricultural Land Ownership or Lease

Two the most important decisions which farmer must make refer to the issues about what land capacity should be managed and how reach it. If it is disposed with too small land capacities, there is a possibility that too small business can not completely use other resources. Too much land capacities can condition need for huge investment of money, which can outgo the possibility of management, too.

Farm production can be conducted on the place, which can be in own property, on a land under the lease or land of combined structure of ownership and the lease (Figure 6) (Census of Agriculture, 2012).

Figure 6. *Areas of Land by Regions*

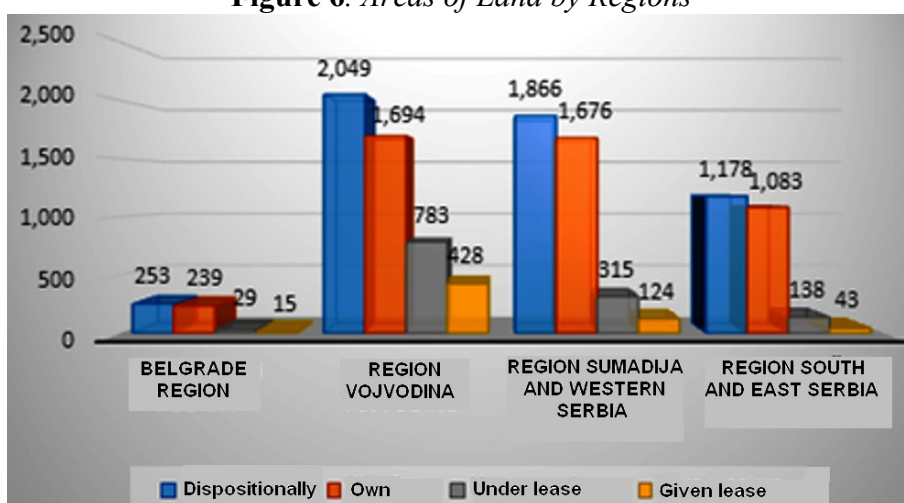

Source: *Census of Agriculture (2012)*

Advantages of production on land in ownership, comparing to production on land under the lease are (Kay et al., 2012):

- Property safeness provides long-term production planning without fear of area reduction;
- Providing credit capability at bancs, because the own land is the one of the best stock funds;
- Long-term of inflation, considering that the growth rate of land prices tend to be equal or above the rate of inflation;
- Independent and free decision-making in all aspects of production;
- Larger part of investing as well as the larger level conservation and improvement of quality and fertility of plots.

Productions exclusively on own land can be a disadvantage, and which is reflected in limited availability of capital (Kay et al., 2012):

- Land purchase by credit can cause the excessive mortgage, so imperil the capital trend, in deed there is a possibility that the profit is not enough for settling the received obligations;
- Alternative investments can have higher annual rate of income from capital invested in land;
- Ultra capital investing in land purchase can negatively affect input investment, thus on profitability.

The agricultural land lease is recommended to those who dispose with limited financial resources, whether it is about beginning of farm production or advancement of existing by increasing the land capacities.

Some of advantages of the land lease (Kay et al., 2012):

- Larger volume of disposable working capital;
- Possibility of engaging lessor for expert advice;
- Greater flexibility of agricultural areas compared to changes;
- Greater flexibility of financial obligations compared to many years fixed-rate credit. The agreed rent in advance is not flexible, but the negotiation about the lease on annual level in relation to the current economic conditions is possible.

As disadvantages of the lease land, we can mark off:

- Insecurity in long-term planning business, because the lease agreement are concluded for a short period from one to several years;
- Insufficient interest of the leaseholder for more serious investing on land an therefore lower incomes;
- Lower possibility of gaining the credit, because the farmers do not have land in ownership, which they can offer as stocks.

The optimal solution in modern conditions of farm business presents appropriate combination of own and leased land, because it provides avoiding huge financial risk. Farmers should be motivated for the lease or redemption of neighboring parcels, which are uncultivated, thus with this linking up, they enlarge their properties, by which the scale economy is achieved.

Necessity of Sustainable Practices in Farm Land Management

The consequences of conventional approach in land resources management are reflected in the degradation of the same (contamination of mineral fertilizers, pesticides, etc.) and production of insecure food (pesticides residues, genetically modified organisms, etc.). The significance and value of sustainable land management have been already recognized in seventies of the last century, period for which the beginning of IFOAM⁵ and organic production are being attached.

In order to decrease negative effect of land farm degradation, practices are brought into such as mulching, plowing the outline, the cultivation of legumes, agroforestry, etc. (Thapa et al., 2012). Organic production presents one of the ways of land preservation or sustainable managing of it, and implies the huge limitations in terms of using of mineral fertilizers, pesticides, heavy machinery, fossil fuels, etc. (Lazic et al., 2008).

Given that the society has interest in preserving farm land, in order to provide food security, it must take care and put set of measures, which will influence that fund, can have productivity in a long-term (Prodanovic, 2015). It is more important to maximize the profit in a long-term, than take relatively higher rate of profit in a short-term. Often lower profit in a short-term can be condition to achieve higher profit in the future, for instance, when it is necessary to invest in investments such as making terraces, drainage and so on (Kay et al., 2012). From that reason, many farmers apply crop rotation and farm fertilizers, although the same rejects a lower level of profit. By farm production, productivity and land quality should be maintained (Thapa et al., 2012).

Using and advancement of agricultural land, through the concept of sustainable agricultural and rural development, as well as the measures of management of it, should have priority in domestic agricultural policy (Subic et al., 2005).

Sustainable housewifery of land resources means:

- The maintenance of desirable pH land value;
- The application of adequate ameliorative measures;
- The reduction of transit of hard mechanization;
- The reduction and restrictions of use of mineral fertilizers and pesticides.

⁵International Federation of Organic Agriculture Movements.

Conclusion

Land management in modern farm production is imposed as one of the most important questions of agricultural production. It presents planning and farm production organizing, which will bring the advantage for farmers, but also for society as a whole.

Strategic management of farm land refers to:

- Preservation of existing areas by preventing repurposing;
- Maintaining its productivity;
- Establishing the unused potential due to intensification of production in accordance with the interests of society and the environment;
- Regulation of the lease and land redemption;
- Increasing the landed property and decreasing the number of parcels, in order to achieve economy of scale.

Essentially, planning concept of land use presents bi-directional relations between planning at different levels: national, regional and local. High involvement of rural population and availability of farm land should be the framework of national plan for land management with aim of advancement complete agricultural sector.

The Law on Agricultural Land could contribute to more efficient land management in long-term, and the most important is to protect it from irresponsible management, encourage economy of scale and development and sustainable agriculture, what the main principles of modern concept modern rural development are.

Conventional approach in farm land management provided efficient using the same, but also led to the numerous problems. Sustainability of agricultural system is imperiled, so intention is on introduction of sustainable practices of management, which will mean the efficiency in the long-term. The aim is to establish the farm production which will maximize the current value of land in long-term, respectively, enabling the farm production, which is focused on maintaining the productivity and land quality during the time, by the realization of profit.

Our chance is that we retain everything that values from traditional land management and traditional farm production, but provide farmers with access to new knowledge.

Literature

1. Bozic Dragica, Muncan Petar, Bogdanov Natalija (2004): *Changes in the ownership structure of farms in Serbia*, Economics of Agriculture, 51 (3-4), 323-333.
2. Cvijanovic Drago, Subic Jonel, Parausic Vesna (2014): *Agricultural farms by economic size and type of production in the Republic of Serbia*, Statistical Office of the Republic of Serbia, Belgrade.
3. FAO (1996): *Guidelines for Land-Use Planning*, FAO Development Series 1. Rome: Food and Agriculture Organization, <http://www.fao.org/docrep/t0715e/t0715e00.htm>. (02.09.2016).
4. FAO (2011): *The state of the world's land and water resources for food and - Managing systems of risk*. Abingdon: The Food and Agriculture Organization of the United Nations and Earthscan, <http://www.fao.org/docrep/017/i1688e/i1688e.pdf> (02.09.2016).
5. Helmholtz Centre For Environmental Research - UFZ. (2013): *Global map provides new insights into land use*. Science Daily, www.sciencedaily.com/releases/2013/11/131105081400.htm (31.08.2016).
6. Kay Ronald, Edwards William, Duffy Patricia (2012): *Farm management*, Seventh Edition, Mc Graw Hill, New York.
7. Lazic Branka et al. (2008): *Organic Agriculture - I*. Institute of Field and Vegetable Crops, Novi Sad.
8. Parausic Vesna, Kuzman Boris, Puskaric Anton (2007): *Situation and perspectives development of agricultural cooperatives in Serbia*, International Scientific Meeting Multifunctional agriculture and rural development in the Republic of Serbian, Jahorina - Sarajevo, Thematic Proceedings p. 224 - 232.
9. Parliament of the Republic of Serbia - *Law on Amendments to the Law on Agricultural Land*. <http://www.parlament.gov.rs/upload/archive/files/lat/pdf/zakoni/2015/292415%20lat.pdf> (30.08.2016)
10. Prodanovic Radivoj (2015): *Influence of Relevant Factors on Production, Processing and Trade in Organic Fruits*, Doctoral dissertation, Faculty of Economics and Engineering Management, Novi Sad.

11. Rankin Bill (2009): *World Cropland*, <http://www.radicalcartography.net/index.html?worldcrops>. (31.08.2016)
12. Statistical Office of the Republic of Serbia(2013): *Census of agriculture 2012 I - Agriculture in the Republic of Serbia*. Belgrade, <http://pod2.stat.gov.rs/ObjavljenePublikacije/Popis2012/PP-knjiga1.pdf> (02.09.2016).
13. Statistical Office of the Republic of Serbia (2013): *Census of agriculture 2012 II - Agriculture in the Republic of Serbia*, Belgrade, <http://pod2.stat.gov.rs/ObjavljenePublikacije/Popis2012/PP-knjiga2.pdf> (29.08.2016).
14. Subic Jonel, Popovic Vesna, Vukovic Predrag (2005): *Sustainable land use in agriculture*. Economics, 51 (5-6), 26-35.
15. Sevarlic Miladin (2014): *The importance of databases on agricultural land in Serbia*, Proceedings, Changing the Census of Agriculture 2012 in the situation of agriculture in the planning of agricultural policy in the Republic of Serbia, p. 245-261, Statistical Office of the Republic of Serbia, Subotica.
16. Sevarlic Miladin (2015): *Agricultural land*. Statistical Office of the Republic of Serbia, Belgrade.
17. Thapa, G. B. and Yila, O. M. (2012): *Farmers' land management practices and status of agricultural land in the Jos Plateau, Nigeria*, Land Degradation & Development, 23 (3): 263-277.
18. Verheye H. Willy (2006): *Management of agricultural land: climatic and water aspects*, In: W. H. Verheye (Ed.), Land use, land cover and soil sciences, Oxford, UK: UNESCO-EOLSS Publishers.

STEPS TO LIBERALIZATION OF INTERNATIONAL TRADE WITH AGRICULTURAL PRODUCTS

Catalin Voica¹, Mirela Panait²

Abstract

In this paper, the authors focused on the evolution of international trade with agricultural products in the period 1993-2013. The main aspects analyzed are the results of international negotiations in GATT and World Trade Organization Uruguay Round and Doha Round – regarding customs duties, export subsidies and market access. All these measures adopted after years of negotiations have positive effects on international trade with agricultural products because, in this way, they laid the foundation of a fair and market-oriented agricultural trading system.

Key words: *agriculture, international trade, competition, market*

Introduction

The trade with agricultural products has an important share of foreign commerce for developed and developing countries for many decades. For this reason, the issues regarding agricultural products are among the main elements of economic policies. In addition, the agricultural trade policies one of the most sensitive aspects in any trade negotiations at international level (Josling et al., 2010).

The issue regarding trade with agricultural products has been placed on the agenda of multilateral negotiations in the Uruguay Round (1986-1994). The main goals of the negotiations were:

- to identify the measures that distorted the commercial flows with agricultural products, including domestic agricultural policies and the subsidization of agricultural exports;

¹Assistant PhD CatalinVoica, Petroleum-Gas University of Ploiesti, 39 Bvd Bucuresti, Ploiesti, Romania, +40722464948, catalin.voica@upg-ploiesti.ro

² Assoc. Prof. PhD Mirela Panait, Petroleum-Gas University of Ploiesti, 39 Bvd Bucuresti, Ploiesti, Romania, +40727733622, mirela.matei@upg-ploiesti.ro

- to promote discipline in this segment of international trade that is important both for developing and developed countries.

After negotiations conducted under the auspices of GATT, the member countries signed the Agreement on Agriculture that is governing currently trade in agricultural products and it created three types of commitments regarding customs duties, export subsidies and market access.

In addition, this agreement has beneficial elements in international trade flows of agricultural products, namely order and fair competition and took in considerations non-trade issues like food security and the need to protect the environment; through these regulations, some distortions affecting trade in agricultural products have been eliminated.

The negotiations were political sensitivity and revealed many problems taking in account the situation of least-developed and Net Food-importing Developing Countries.

According with this agreement, the access on agricultural market assumes a regime based solely on customs duties because the non -tariff barriers are replaced by customs duties ensuring equivalent protection. So, the non tariff barriers like quantitative import restrictions, minimum import prices, variable import levies, voluntary export restraint agreements and discretionary import licensing procedures are no longer permitted. The agreement established some goals differentiated by the level of development of the signatory countries. So, the new customs duties resulting from the "tariffication" process had be reduced on average by 36% in six years for developed countries and 24% in ten years for developing countries. For less developed countries, there was no obligation to reduce customs duties for agricultural products. Another aspect covered by the agreement refers to export subsidies. After negotiations, the signatory states have committed themselves to reduce costs for both export subsidies and the quantities of subsidized exports of certain products.

Another sensitive aspect that has influence on agricultural trade was the domestic support for agricultural producers. The goal was the reduction of product-specific support and non-product-specific support measured in terms of a "Total Aggregate Measurement of Support" (Total AMS). In order to discipline and reduce domestic support, the commitments of

countries was different in accordance with their status: 20 % over 6 years for developed countries and 13 % over 10 years for developing countries. The export subsidies for industrial products were subjects of negotiations under the GATT 1947 and the results were the prohibition of their use. These subsidies were used for agricultural products as a measure in order to boost the exports. In order to create a fair and market-oriented agricultural trading system, the Agreement on Agriculture imposed some limits regarding these instruments. The public authorities could be used export subsidies only in some situations presented in this agreement. In a period of 6 years, for developed countries, the targets are the reductions of volume of subsidized exports by 21% and the budgetary outlays for export subsidies by 36%. In a period of 10 years, for developing countries the required cuts are 14% regarding the volumes, and 24% for budgetary outlays.

Table 1. Numerical targets for cutting subsidies and protection (the reductions in agricultural subsidies and protection agreed in the Uruguay Round)

	Developed countries 6 years: 1995–2000	Developing countries 10 years: 1995– 2004
Tariffs		
average cut for all agricultural products	–36%	–24%
minimum cut per product	–15%	–10%
Domestic support		
cuts in total (“AMS”) support for the sector	–20%	–13%
Exports		
value of subsidies (outlays)	–36%	–24%
subsidized quantities	–21%	–14%

Source: *WTO*

This round of negotiations took effect both on the Common Agricultural Policy of the EU (CAP) and the US policies.

CAP was created at EU level taking into account the specific economic and social realities of the immediate period after the Second World War (IER, 2003, Radulescu, 2009). Being the first community policy, it met a complex process of negotiation, disagreement, and conflict mediation between states members (Andrew & Darvasi 2012). Adapting to the

changes recorded on European and international level, the improvement of its mechanisms of functioning are some of the basic features of this economic policy. (Jean-Vasile &Untaru, 2012).

Thus, negotiations undertaken in the Uruguay Round imposed the radical change of the CAP architecture. This modification was recorded in 1992 when the Commissioner for Agriculture, Ray MacSharry that proposed a package of measures taking in account:

- internal conditions (high budget spending and overproduction);
- USA's pressures to reduce interventionism.

In the USA ,the transposition of the results undertaken in the Uruguay Round's negotiations were materialized in adoption of a specific normative act - The Federal Agriculture Improvement and Reform Act of 1996 (informally known as the FAIR Act, or the 1996 U.S. Farm Bill). The central element of this act is the elimination of production controls and decoupling of farm subsidies from prices. Taking in account this consideration, some Specialists think that the year 1996 marked the end of supply management policy in the US. (Winders et al 2016). A new important step in order to improve the American trade policy was The Farm Security and Rural Investment Act of 2002 known as the 2002 Farm Bill that covered different issues, agriculture being an important title of this act.

In the World Trade Organization, a new round of negotiations has launched in 2001 – The Doha Round. The area of topics was large and included agriculture, services, trade and development, trade and environment. Regarding the agriculture, the negotiations were based on the article 20 from the GATT's Agreement on Agriculture and the issues discussed were market access; subsidies in agriculture; sanitary and phytosanitary measures, geographical indications.

Negotiations began in 2001 and recorded some suspensions because to the disagreements between developed countries and developing countries. In 2006, the discussions have reached a blockage due to disagreements on agriculture issues like reduction of customs duties and agricultural subsidies. The interests of negotiators were focused on reducing trade-distorting subsidies and tariffs.

In Doha Round negotiations, we note some intense divergent discussions between USA and EU (the main problem for USA was the trade-

distorting domestic support, in the case of EU, the main request from USA were reductions in tariffs and to limit the number of import-sensitive and special products) and the decisive role played by developing countries.

The negotiations in Doha Round recorded some troublesome since the first years and serious blockages was registered during WTO meeting at ministerial level in Geneva in July 2008. The cause of this situation was the major disagreement between developed countries and those in development regarding the issue of customs duties` reduction on industrial products.

At the WTO ministerial conference in December 2013, from Bali, the negotiations were finalized by adopting "package to Bali" containing ten decisions regarding aspects like facilitation of trade, certain agricultural issues (such as food security, cotton), a set of measures to support the development and an important agreement - the Trade Facilitation Agreement (TFA), which aims to streamline the movement of goods and customs procedures (Ghibuțiu, 2015).

After the meeting from Bali, Nairobi was the latest point on this road (of negotiations in Doha Round) at the end of 2015. The topics for this meeting were, in some extent, related to the original Doha agenda and the most contentious topic was agricultural products` trade taking in account the problems discussed (for example domestic support, export subsidies, cotton subsidies, stockpiling for food security, safeguard mechanisms) but divergences between developing countries and developed countries remain. For the issue of export subsidies, negotiations were successfully ended, the decision being the elimination of these subsidies. Even if we note this success, some experts draw attention to the problem of transformation (restructuring) of these instruments into another protectionist measure - domestic subsidy that are covered by discussions/negotiations at the conference in Nairobi (Lester, 2016). The multiple negotiations that took place in the WTO have led developing countries and those developed to make strides in liberalizing agricultural trade. For example, the EU, one of biggest protectionists together Japan, made important steps in the process of agricultural trade liberalization after major reforms that took place in 2003, 2008 and 2013 the agriculture support policies were switched and export subsidies are eliminated (Baldwin, 2016).

International production and trade of agricultural products

At international level the production of agricultural product had an ascendant trend in the analyzed period. This trend wasn't ascending through the entire period. We see from Chart 1 that there was a strong increase in the first part between 1993 and 1996 followed by a smooth decrease between 1995 and 2002, when a strong ascending trend started between 2003 and 2013 which was only interrupted in 2009 as a result of the international financial crisis. Between 1993 and 2013 the gross production value of agricultural products increased 3.4 times from 1,147,199.291 million USD in 1993 to 3,904,000.588 million USD in 2013.

Chart 1. *Gross production value, billion USD*

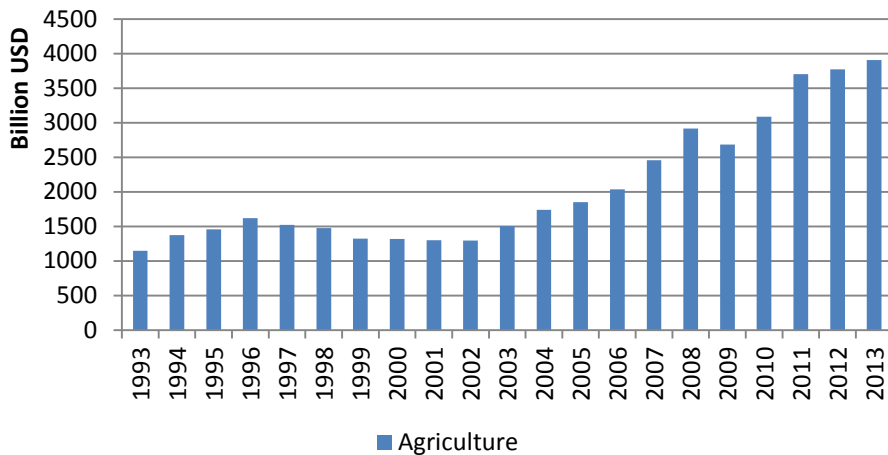

Source: *FAOSTAT*

This strong ascending trend from the last period was generated by the increase of international trading and the development of international markets which facilitate the move of agricultural goods to parts of the world that previously didn't use them.

New developments in international trade and markets allowed the formation of new and complex supply chains in order to accommodate the increasing demand of agricultural goods in the developed and developing parts of the world.

Also, in order to cover the demand of agricultural products, new technologies were introduced to the agricultural goods production in order to ensure a higher level of productivity in an intensive manner.

As demand for agricultural goods increases, the investments in R&D are growing providing a fast development of the technologies used in this field.

In Chart 2, we can observe the distribution of agricultural production between the main regions of the world. In the analyzed period, each of the region registered significant increases.

Chart 2. *Gross production value by region, billion USD*

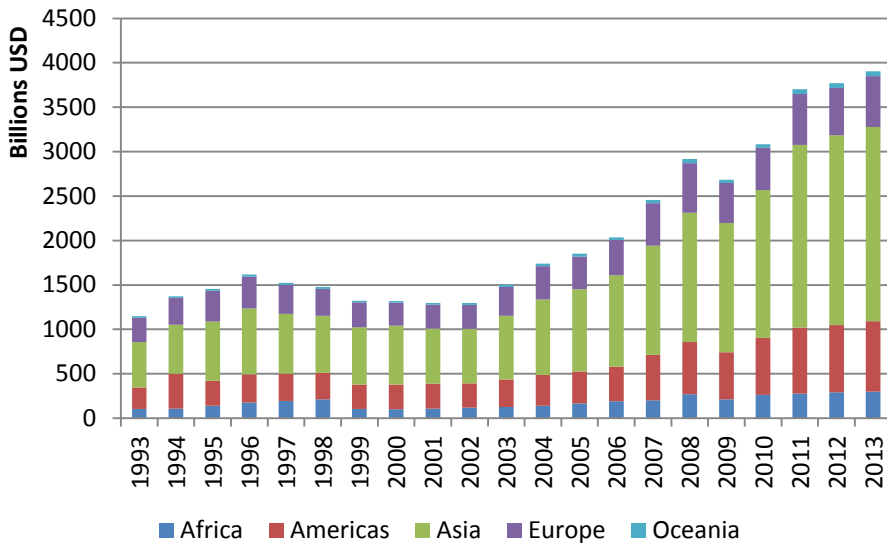

Source: *FAOSTAT*

If we analyze each region we see that

- Asia has the highest increase rate with an increase of 4.27 times from 511,884.3 million USD in 1993 to 2,187,085.7 million USD in 2013,
- on the second place is America with an increase of 3.27 times from 242,217.5 million USD in 1993 to 792,299.6 million USD,
- third is Oceania with an increase of 3.2 times from 16,437.1 million USD in 1993 to 52,635.6 million USD in 2013,

- followed by Africa with an increase of 2.9 times from 102,726.1 million USD in 1993 to 298,155.5 million USD in 2013 and
- last is Europe with an increase of 2.1 times from 273,934.3 million USD in 1993 to 573,824.2 million USD in 2013.

Analyzing the share of gross value of production in 2013 we observe that Asia placed first with a share of 56%, second place is owned by Americas with 20%, third is Europe with 15%, fourth is Africa with 7.6% and last is Oceania with 1.3%.

By merging these two analyses we can extract a few important conclusions. Firstly, Asia is the uncontested leader regarding the gross value of agricultural products by making a better use of the vast land that it has and introducing new technologies into agriculture. Secondly, Africa still can't achieve its full potential because of low technological and managerial endowments that it uses, even though it placed third at the gross production value increase rate. Thirdly, Europe reached its limits of extensive and intensive land use and there is no prospect of further increasing its agricultural production, with the exception of ex-communist countries or the addition of new members, by conventional means. As some of the most traded at international exchanges are the cereals we will further analyze the international production, harvested area and trade.

Chart 3. *Cereal area harvested by region, million ha*

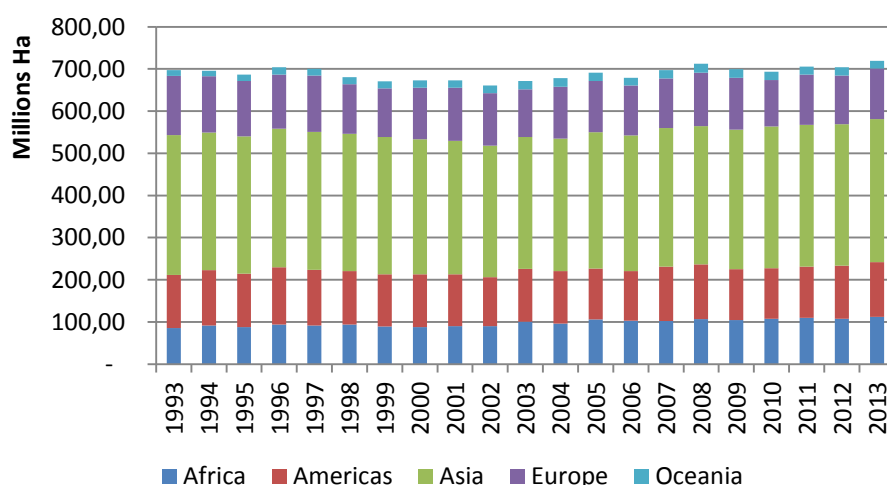

Source: FAOSTAT

As we can observe from Chart 3 the total cereal area harvested at global level didn't change very much in the analyses period. However there have been some significant changes in the repartition of these areas per region. Four out of five regions registered increases of the cereal area harvested as it follows: Africa registered an increase of around 31% from 85 million Ha in 1993 to 112 million Ha in 2013, Americas registered an increase of around 3% from 126 million Ha in 1993 to 129 million Ha in 2013, Asia registered an increase of around 2% from 331 million Ha in 1993 to 339 million Ha in 2013 and Oceania registered an increase of around 31% from 13 million Ha in 1993 to 18 million Ha in 2013. The only region that registered a decrease of the cereal area harvested is Europe with a decrease of around 14% from 140 million Ha in 1993 to 120 million Ha in 2013.

The highest share of the cereal area harvested in 2013 is the one of Asia with 47% of total followed by Americas with 18%, Europe with 17%, Africa with 16% and Oceania with 3%.

In Table 1 we have the production of cereals in 2013 classified by the main types of cereals.

Table 2. *World cereal production and share by type in 2013, tonnes*

Cereal Type	Barley	Buckwheat	Canary seed	Cereals, nes	Fonio
2013	143,600,051	2,263,475	229,719	6,422,058	612,485
%	5.19%	0.08%	0.01%	0.23%	0.02%
Cereal Type	Grain, mixed	Maize	Millet	Oats	Quinoa
2013	3,830,833	1,017,750,854	25,780,455	23,881,333	114,112
%	0.14%	36.80%	0.93%	0.86%	0.00%
Cereal Type	Rice, paddy	Rye	Sorghum	Triticale	Wheat
2013	738,089,040	16,680,940	60,725,369	14,462,668	711,407,394
%	26.69%	0.60%	2.20%	0.52%	25.72%

Source: *FAOSTAT, authors' calculations*

The highest share of cereal production is that of maize with a share of 36.8% followed by paddy rice with a share of 26.69%, wheat with a share of 25.72%, barley with 5.19% and sorghum with 2.20%. The next cereals that have a share of less than 1% are millet, oats, rye, triticale, mixed grains, buckwheat, canary seed and quinoa.

We analyzed the trade of agricultural products in general and cereal in special by exploring the imports and exports at global level and by regions.

The international trade with agricultural products has specific determinants taking in account some considerations that the increase of global populations, the use of grains for bio-fuels with consequences on food security (Radulescu, Popescu 2015), the greater demand for meats, grains in countries like China and developing countries, increase in agricultural prices, especially after the mid 2000s (Aksoy, Ng, 2010, Ene 2009, Stancu 2015) and geographical distribution of the main producers countries for main food products (corn, soybeans, wheat, cocoa and coffee). For example, corn, soybeans, wheat are produced in and exported from the core of the world economy (USA and UE) and non-core countries, such as Brazil, Vietnam, Mexico, Colombia, Ethiopia, and Indonesia are the producers and exporters for cocoa and coffee. Trade and price stability in markets of these products are different because of the economic power of producing countries and consuming countries (that are the same for corn, soybeans, wheat, but different for cocoa and coffee (Winders, 2016).

In Chart 4 we depict the evolution of agricultural export values between 1993 and 2013. Those have increased by 4.12 times from 338 billion USD in 1993 to 1,397 billion USD in 2013.

Chart 4. *Exports of agricultural products, billion USD*

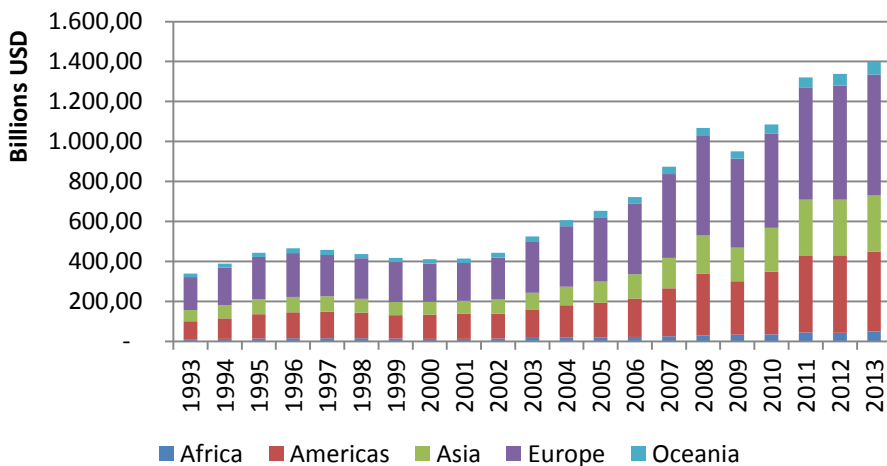

Source: *FAOSTAT*

This increase was different for each region as Asia increased 5.09 times from 55 billion USD in 1993 to 281 billion USD in 2013, Africa increased 4.71 times from 10.5 billion USD in 1993 to 49.6 billion USD in 2013, Americas increased 4.42 times from 90 billion USD in 1993 to 399 billion USD in 2013, Oceania increased 3.7 times from 16.6 billion USD in 1993 to 61.5 billion USD in 2013 and Europe increased 3.6 time from 166 billion USD in 1993 to 605 billion USD in 2013.

If we analyze the share of each region in 2013 we observe that Europe places first with a share 43.3% followed by Americas with a share of 28.6%, Asia with a share of 20.2%, Oceania with a share of 4.4% and Africa with a share of 3.6 %.

By comparing the level of production and the level of exports we observe that even though Europe and Americas are not the number one producers from the world they definitely are the top exporters.

In Chart 5 we analyze the evolution of imports value of agricultural products and we observe that at global level the imports increased 4.02 times from 355 billion USD in 1993 to 1,430 billion USD in 2013.

Chart 5. Imports of agricultural products, billion USD

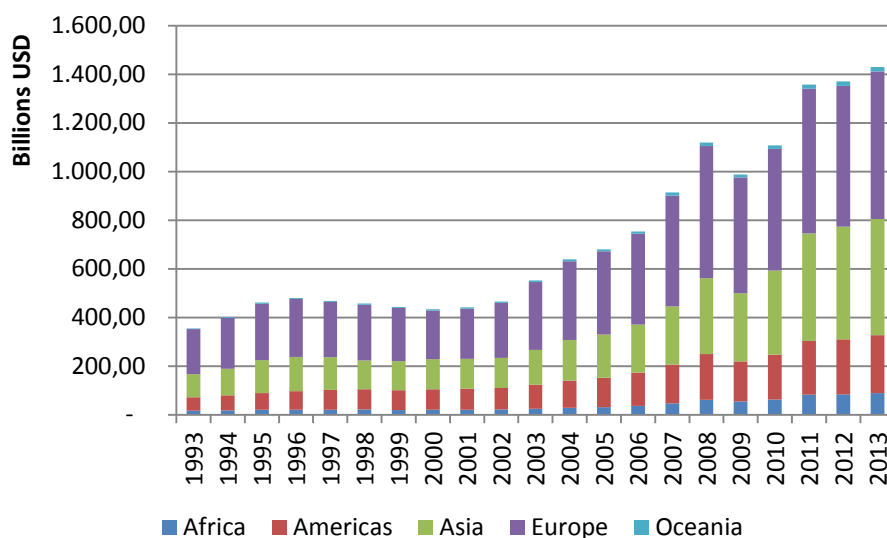

Source: FAOSTAT

As in the case of exports this increase was differentiated by region. The highest increase in imports was in Oceania with an increase of 5.5 times from 3.4 billion USD in 1993 to 18.7 billion USD in 2013 followed by Africa with an increase of 5.46 times from 16 billion USD in 1993 to 88.5 billion USD in 2013, Asia with an increase of 5 times from 95 billion USD in 1993 to 478 billion USD in 2013, Americas with an increase of 4.2 times from 55 billion USD in 1993 to 238 billion USD in 2013 and Europe with an increase of 3.3 times from 184.7 billion USD in 1993 to 606 billion USD in 2013.

The share of the imports in 2013 was as it follows Europe with a share of 42% followed by Asia with a share of 33%, Americas with a share of 17%, Africa with a share of 6% and Oceania with a share of 1%. Next we will analyze the regional values of imports and exports in 2013 for the main cereals that are produced at global level: maize, rice and wheat. Those are some of the most traded cereals at global exchanges.

Chart 6. *Regional import-exports of maize, billion USD*

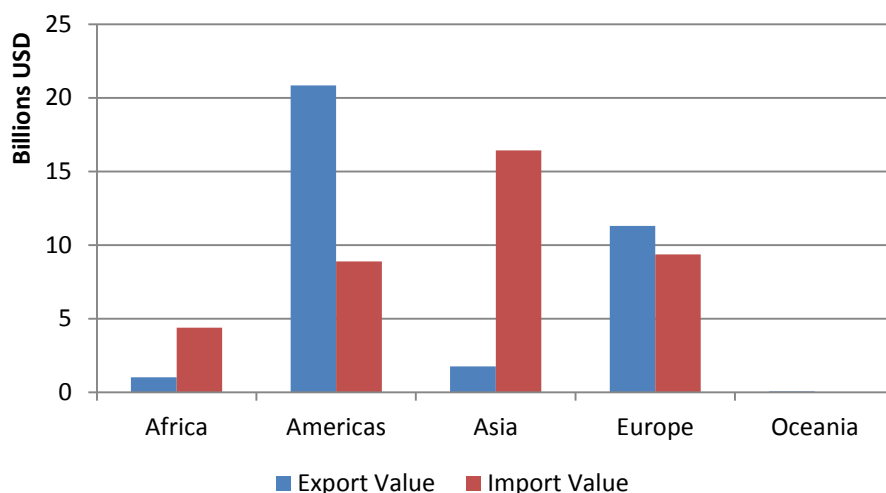

Source: *FAOSTAT*

In Chart 6, we observe the distribution of imports and export of maize between the main regions of the world. In 2013 there were registered imports of maize with a value of 34 billion USD and exports of 39 billion USD.

The highest share of exports was registered by Americas with a share of 50% followed by Europe with a share of 32%, Asia with a share of 5% Africa with a share of 3% and Oceania with 0.2%.

The highest share of imports was registered by Asia with a share of 42% followed by Europe with a share of 24%, Americas with a share of 23%, Africa with a share of 11% and Oceania with a share of 0.02%.

By analyzing the numbers we conclude that the main exporter of maize is Americas and the top importer is Asia.

In Chart 7 we observe the distribution of regional imports and exports of rice. In the case of rice the global exports value in 2013 is 24 billion USD while the imports are 26 billion USD.

The highest share of exports was registered by Asia with a share of 73% followed by Americas with a share of 16%%, Europe with a share of 8%, Africa and Oceania with a share of 2% each.

The highest share of imports was registered by Asia with a share of 44% followed by Africa with a share of 29%, Americas with a share of 14%, Europe with a share of 13% and Oceania with a share of 1%.

Chart 7. *Regional import-exports of rice, billion USD*

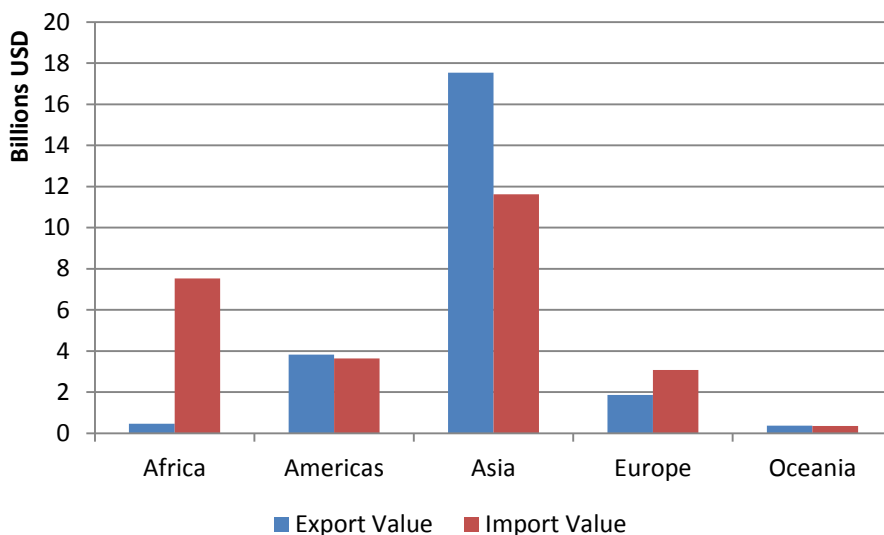

Source: *FAOSTAT*

Asia is the top exporter of rice mainly because of the natural endowments of the region, while Africa is the top importer because of the low development of agriculture and the increasing population.

Chart 8. *Regional import-exports of wheat, billion USD*

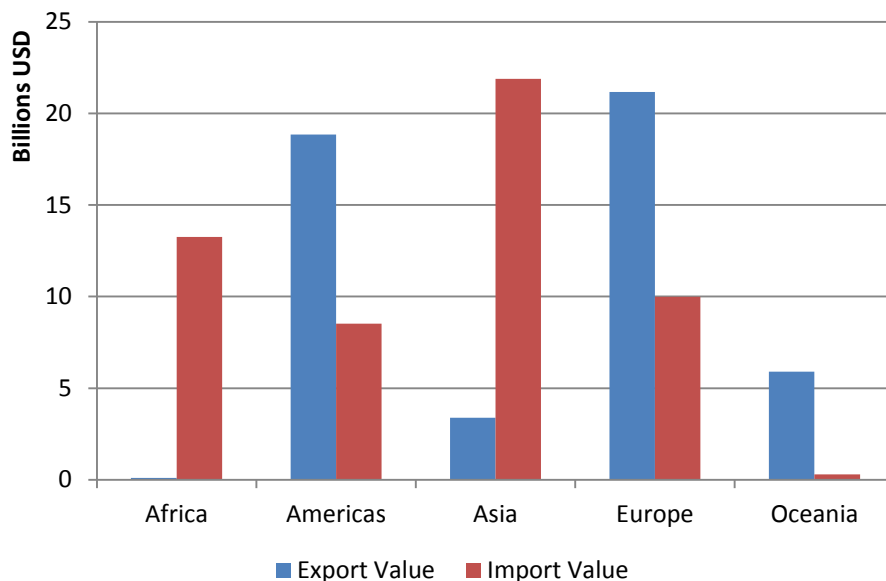

Source: *FAOSTAT*

In Chart 8 we observe the distribution of imports and export of wheat between the main regions of the world. In 2013 there were registered imports of maize with a value of 49 billion USD and exports of 54 billion USD.

The highest share of exports was registered by Europe with a share of 43% followed by Americas with a share of 38%, Oceania with a share of 12% Asia with a share of 7% and Africa with 0.2%.

The highest share of imports was registered by Asia with a share of 41% followed by Africa with a share of 25%, Europe with a share of 18%, Americas with a share of 16% and Oceania with a share of 1%.

In the case of wheat, the top exporters are Europe and America and a smaller exporter is Oceania. The top importers are Africa and Asia.

Conclusions

The agricultural products market is in a continuous expansion in the context of population increase trend. The diversification of diet around the world is generating an increase level of imports and exports as products must be transferred from the region where conditions are optimum for efficient production to regions where they are not or the level of technological development is insufficient developed as is the case of Africa.

Another aspect that we must acknowledge is the food security problem which must be addressed by the international community because the number of people is growing at a fast pace.

The development of agricultural trade was largely due to the efforts of international organizations - GATT and WTO have provided the institutional framework for the conduct of negotiations. Even if the Doha round was marked by the development over a very long time and by repeated blocking negotiations, the results recorded at the ministerial conference in Nairobi are encouraging. The financial institutions like the International Monetary Fund and World Bank supported the international process of liberalization of flows of agricultural products through conditioning the granting of loans by the elimination or cut of barriers. The EU and US continue to be two entities with the highest number of farms in the world and they "fight" for first place in the export of agricultural products. The main players in the international market of agricultural products are the EU and US, its being the main voices in the case of internationally run negotiations.

Literature

1. Aksoy, A., & Ng, F. (2010). The evolution of agricultural trade flows. *World Bank Policy Research Working Paper Series*.
2. Andrei, J. V., & Darvasi, D. (2012). Perspectives and Challenges in financing the new Common Agricultural Policy: a new paradigm. *Journal of Food, Agriculture & Environment*, 10(1), 904-907.
3. Andrei, J. V., & Ungureanu, A. (2014). The importance of economic structure evolution in achieving performance-from agrarian economy to competitiveness in Romanian economy. *Economic of Agriculture/ ekonomiku poljoprivrede*, 61 (4), 945.

4. Baldwin, R. (2016). The World Trade Organization and the Future of Multilateralism. *The Journal of Economic Perspectives*, 30(1), 95-115.
5. Bouët, A., Bureau, J. C., Decreux, Y., & Jean, S. (2005). Multilateral agricultural trade liberalisation: The contrasting fortunes of developing countries in the Doha round. *The World Economy*, 28(9), 1329-1354.
6. Ene, C (2009), *Securitate aalimentară – coordonate și implicații*, Editura Universității Petrol-Gaze din Ploiești
7. Ene, C. (2013), *Food Traceability – Actual Coordinates at National, European and International Level*, QUALITY - Access to success, Vol. 14, No. 135, pp. 103-107
8. Gabriela, R. I., & Catalin, P. (2015). Renewable Energy Strategies: Where European Union Headed?. *Annals-Economy Series*, 102-107.
9. Ghibuțiu, A. (2015). The Evolution of World Trade in 2014 and the Prospects for 2015-2016. *Recent Trends in the World Trading System*.
10. Hertel, T. W., Anderson, K., Davis, C. L. (2004). International institutions and issue linkage: Building support for agricultural trade liberalization. *American Political Science Review*, 98(01), 153-169.
11. Jean-Vasile, A., & Untaru, M. (2012). Through Common Agricultural Policy Reforms: A Short Analysis. *International Journal of Sustainable Economies Management (IJSEM)*, 1(3), 32-40., <http://www.igi-global.com/article/content/69955>
12. Jean-Vasile, A., Mieila, M., & Smoleanu, A. (2015). The Influence of Common Agricultural Policy (CAP) on Development of the Agricultural Production Structures in Romania and EU-28. *Agricultural Management Strategies in a Changing Economy*, 52.
13. Josling, T., Anderson, K., Schmitz, A., & Tangermann, S. (2010). Understanding international trade in agricultural products: one hundred years of contributions by agricultural economists. *American Journal of Agricultural Economics*, 92(2), 424-446.
14. Lester, S. (2016). Is the Doha Round Over? The WTO's Negotiating Agenda for 2016 and Beyond. <https://www.cato.org/publications/free-trade-bulletin/doha-round-over-wtos-negotiating-agenda-2016-beyond>

15. Lindland, J. (1997). The impact of the Uruguay Round on tariff escalation in agricultural products. *Food Policy*, 22(6), 487-500.
16. Radulescu, I. G. (2009), *Comert international*, editiaa II-a, Editura Renaissance, Bucuresti, 2009.
17. Stancu, A. (2015). The Relationship among Population Number, Food Domestic Consumption and Food Consumer Expenditure for Most Populous Countries. *Procedia Economics and Finance*, 22, 333-342.
18. Vasile, A. J., Dorel, D., & Mihai, M. (2015). The influences of the cultural models on agricultural production structures in Romania and some EU-28 countries-a perspective. *EkonomikaPoljoprivrede*, 62(2), 293.
19. Winders, B., Heslin, A., Ross, G., Weksler, H., & Berry, S. (2016). Life after the regime: market instability with the fall of the US food regime. *Agriculture and Human Values*, 33(1), 73-88.
20. Institutul European din Romania, *Politica Agricola*, 2003, http://beta.ier.ro/documente/formare/Politica_agricola.pdf

Internet source:

21. <https://ec.europa.eu/jrc/en/research-topic/agricultural-markets-and-international-trade>
22. http://www.dce.gov.ro/Materiale%20site/texte_ref/ACORDUL_PRIVIND_AGRICULTURA.html
23. https://www.wto.org/english/docs_e/legal_e/14-ag_01_e.htm
24. http://www.dce.gov.ro/poli_com/relatiile_ue-omc.html
25. <https://www.fao.org>

STATE AND PERSPECTIVES OF FOREIGN TRADE EXCHANGE OF FRUIT - THE EXAMPLE OF SERBIA

Dejan Đurić¹, Dragana Đurić²

Abstract

Insufficient level of export and high trade deficit are still a negative characteristic of Serbian trade exchange with foreign countries. Considering the need for Serbian export recovery and the strengthening of the competitiveness on a global level, the export of fruit and fruit products has been the focus of the attention as a developmental chance for Serbian economy in this paper. With regard to that, the main objective of this paper's analysis is the state of foreign trade fruit and fruit products exchange, as well as an overview of measurements which should be taken with the aim of encouraging export and raising the level of competitiveness in foreign market.

Key words: *export, fruit, fruit products, international competitiveness*

Introduction

Contemporary economy of a country cannot be imagined without foreign exchange. Besides the fact that export represents a source for financing needs for import, it enables expanding of the domestic market and realisation of products of domestic production on world market. If it was not for that, it could not expand, because domestic market becomes too narrow for increased production. Having in mind the afore mentioned characteristics of foreign trade activities, it is clear that in contemporary conditions of economy all countries strive towards improvement and strengthening of foreign trade, before all, export of goods and services.

The agrarian sector has an extremely important role in the economic development of the Republic of Serbia. Creating a competitive

¹ Dejan Đurić, PhD, Professor, Business School of Professional studies Novi Sad, Serbia; email: ddjuric971@gmail.com, 0381638057420.

² Dragana Đurić, PhD, Professor, Business School of Professional studies Blace, email: djdragana@ikomline.net, +381658057420.

agricultural market or to be more specific, market of fruit and fruit products, could contribute to strengthening of total competitiveness of domestic economy and its more active participation in international good exchange to a great extent. This paper emphasises the importance of fruit production in Serbian economy, reflecting on foreign trade exchange of agricultural goods and the state of fruit and fruit products export, thus acquiring methods of improving competitiveness of agrarian sector.

The subject of this paper's research includes the potentials of development of fruit and fruit products production and improving competitiveness of this sector. Raising competitiveness of fruit production must imply respecting standards and production of unique products, characteristic for this area exclusively.

The Republic of Serbia possesses extraordinary natural conditions and resources for development of fruit and fruit products production. On the territory of Serbia there could be grown an abundance of various types of fruit, very well-known across the whole world, which represents a vital potential to be utilized in its entirety. With regard to that, this paper points to the most important issues fruit and fruit productions producers face (export issues, poor marketing, etc.), but also possible solutions of these issues which would be functional in improving competitiveness of agrarian sector.

Creating characteristic of foreign trade exchange of Serbia

Having in mind the state of foreign economy activities, it is clearly visible that the increase of goods and services export in gross domestic production imposes itself as one of the most important tasks which should carry the economic policy in the years to come. That task is primarily important because of the need to ensure a stable foreign exchange inflow which would be sufficient for neat servicing of obligations towards foreign countries and, as well as paying for needed import.

Despite the revival of export activities in the period after 2000, there still exist numerous issues which restrict a greater strengthening of Serbian economy export dynamics.

To begin with, we emphasise an inadequate structure of Serbian economy, i.e. unfavourable structure of export, which could not supply a satisfactory level of competitiveness on foreign market. In the structure of

export products for reproduction, i.e. products of low-level processing are still dominant, thus making structural changes in real sector a basic presumption in order to raise export competitiveness to a higher level.

The Republic of Serbia, as a relatively small country, with an insufficiently developed infrastructure and modest developmental resources, must strive towards building an export-oriented economy, with developed sector of exchangeable goods (industry and agriculture). In such a country, a need for increasing import is imposed, for following reasons:

- Restriction of domestic market cannot secure an economy of volume, and by that, one of the most important condition for strengthening competitive position of domestic companies on the foreign market;
- The lack of basic production input as well as the necessity of satisfying the needs of all citizens, through the purchase of goods and services, necessarily leads to import increase, which increases the need for a larger export in order to maintain the foreign trade sector in a balance. A small country cannot supply an assortment of goods wide enough and therefore must import, supplying a sufficient level of export in order to pay for export (Đurić et al., 2016, pp.532-533).

Having in mind the significance of export for the Republic of Serbia, it is clear that without its increase, the Republic cannot achieve its economic goals. With regard to that, the main task of economic policy in the period to come is the increase in export, so that the following could be achieved:

- To increase the production, and by that employment and life standard of citizens;
- To ensure macroeconomic stability, through decreasing sensitivity of economic growth to the size of capital inflow, and
- To enable a neat servicing of foreign debt (Ministry of finances of the Republic of Serbia, 2011, p.1).

Based on the data on movements in foreign trade sector of Serbian economy after 2000, we can conclude that in the years after 2000, the main characteristic of trade balance of our country is the existence of a high level trade deficit.

It was maintained on a relatively high level above 20% of GDP, whereas in 2004, it was 30% of GDP.

Table 1. *Foreign trade balance of goods of the Republic of Serbia for the period from 2000 to 2014 (mil. USD)*

Year	Export	Import	Balance	Export coverage (%)	Foreign trade deficit as % of GDP
2001	1.720	4.260	-2.540	40	21
2002	2.074	5.614	-3.540	36	22
2003	2.756	7.477	-4.721	36	24
2004	2.523	10.755	-7.232	32	30
2005	4.480	10.461	-5.981	41	24
2006	6.431	13.174	-6.743	48	23
2007	8.823	19.165	-0.342	46	25
2008	10.974	24.332	-13.358	45	25
2009	8.345	15.808	-7.463	52	19
2010	9.794	16.471	-6.677	59	17
2011	11.780	19.862	-8.082	59	17
2012	11.229	18.928	-7.699	59	19
2013	14.612	20.553	-5.941	71	13
2014	14.845	20.650	-5.805	71	13

Source: <http://webrsz.stat.gov.rs/WebSite>

Based on the movements in foreign trade in the last several years, we can notice that the participation of goods export almost continuously increases, which, along with stabilization of participation of goods import, led to a noticeable decrease in participation of foreign trade deficit. However, that does not imply that there has been a great progress in export activities. We conclude that based on the fact that Serbian export is still significantly lower in comparison to GDP in similar countries of Central Europe. While export of goods and services in Serbia in 2014 was 44% of GDP, the participation of export in GDP in countries of similar size (Bulgaria, Czech Republic and Hungary) in the same year was 80%. Starting from the level of foreign debt of a country and the need to import of raw materials and reproduction material for domestic production needs, the export coefficient should achieve the value above 50% GDP (Ministry of finances of the Republic of Serbia).

According to what was stated earlier, Serbia has got more than enough space for the increase of export and decrease of foreign deficit on that basis. Besides that, the increase in export represents the key initiator of sustainable growth of Serbian economy in the years to come, so two-digit

rates of export increase would represent a signal that Serbia is on a sustainable path of growth (Quarter Monitor no. 40, 2015).

With regard to the fact that from the perspective of economic interest of our country it is of utter importance to intensify and strengthen competitiveness on a global plan, in the following part the focus is on the economic significance of fruit growing and fruit and fruit products export as a developmental chance of domestic economy.

Economic significance and potentials of development of fruit and fruit products production

Serbia possesses very favourable natural conditions for the development of various agricultural productions. It is situated on the most convenient territory of the north latitude, with four seasons and four climate areas. It is, thus, very convenient for agricultural production. Convenient soil and climate conditions enable the development of various agricultural productions (both crop and livestock breeding) especially: wheat, industrial plants, fruit and vegetables, seeds and planting material, herbs, large and small cattle.

Fruit growing represents one the important branches in Serbian economy. Fruit growing, as a field in crop production, is characterized by an arrow of comparative advantages in comparison to other agricultural branches, which means that production and processing of fruit should be given more attention. In Serbia, there exist convenient climate conditions for fruit growing. Fruit growing records its greatest increase in the last year and currently in Serbia 238,000 hectares are covered in orchards, which represents 4.69% of total agricultural territory, or 5.64% of arable land in the Republic of Serbia. In Central Serbia orchards occupy around 6.65% of agricultural land, whereas in Vojvodina, that share is only 1%.

Lands with less convenient physical and chemical characteristics, as well as lands with higher slopes can be used for fruit growing production. Besides this, this type of production enables using different locations, with different climate conditions. The fact that this type of production achieves values by hectare which is ten to twenty times higher than that achieved by wheat and corn production only confirms its profitability. Of course, high profitability of fruit production can be discussed only if its technology is coordinated with market demands.

Table 2. *Agricultural land according to categories of its use (2012)*

Categories of agricultural land		in 000 ha	in % comparing to the total amount	in % comparing to arable
1.	Plough lands and gardens	3.282	64,62%	77,86%
2.	Orchards	238	4,69%	5,64%
3.	Vineyards	54	1,06%	1,28%
4.	Meadow	641	12,62%	15,20%
5.	Arable land in total (1+2+3+4)	4.215	82,99%	100,00%
6.	Pastures	837	16,48%	
7.	Ponds, fishponds and reeds	13	0,53%	
Total (5+6+7)		5.065	100,00%	

Source: *Republican Bureau of Statistics*

Serbia possesses exceptionally convenient agro ecological conditions to grow all types of continental fruit, which are not still used to their total potential. It is necessary as well to point to the fact that our country is rich in quality water which could be used for irrigation. It is very well-known that fruit production contributes to development of a variety of other industrial branches: manufacturing, chemical, pharmaceutical industry, as well as other service activities: trade, tourism, traffic, etc.

In order for fruit and fruit products production to become the skeleton of our agricultural production, there are some conditions to be met and various restrictions present in this field to be eliminated. As a key issue, the lack of middle-term and long-term strategies of fruit growing development is pointed. In addition to that, a great issue is the fact that certain fruit types are grown in the places which lack conditions; subsidies for new plants are insufficient, which makes Serbia less competitive in comparison to other countries. Additional issues of fruit production are represented in small lands, poorly organized advice service, inadequate and unorganized nursery production, lack of manpower for picking, etc (Nikolic et al., 2012, p.15). In addition to afore mentioned issues, we should mention administrative restrictions and obstacles our producers in this area face, the elimination of which would contribute to increase in fruit production and strengthening of export activities to a great extent. In order to raise the level of contemporary ways of domestic fruit and fruit products production competitiveness, it is

necessary to intensively introduce contemporary ways of production which should take place according to precisely specified standards with using contemporary technologies.

Besides increase in production volume, it is very important to maintain recognizable qualitative characteristics of our fruit and fruit products ensure biological values, necessary productivity and economic production. This can only be achieved by synchronizing all the participants in the reproduction chain.

Intensive production and processing of fruit cannot be achieved without a good connection of all the participants in the production chain, starting from the production, through marketing activities, environmental protection, to the finalization of final products. Such production is, by rule, expensive, but exclusively possible in order to survive on the market. Given aims cannot be achieved without good communication among all the levels of management, team work, management with participation of all the employees, development of ideas and creativity, flexibility, conflict avoidance, adjustment to a change in conditions, grading and giving awards, creating a vision for the future.

Perspectives of growing, production and yield of continental fruit

Serbia has very convenient conditions for growing different continental types of fruit. As it was pointed earlier, in order to improve fruit growing production, it is necessary to introduce contemporary ways of production, which include production according to precisely specified standards, using contemporary technological achievements. Production capacities in fruit growing are expressed through the percentage of used arable land and number of bearing trees. With regard to that, the focus is on the following most present types of fruit in our country:

Plum occupies the first place according to land planted with it and achieved production in Serbia. It is grown on 58.7% of the total of private farms, with significantly different representation in private farms in certain areas. According to the number of trees and production, Serbia is fourth in the world, after the USA, China and Romania (Statistical annual of the Republic of Serbia, 2012). Most of the produced plums are processed, whereas a very small part is imported. More than 85% of produced plums are processed into brandy, whereas the rest is processed into prunes, jam, and other products such as candied fruit.

Low level of techniques and technology in plum production is reflected to relatively small and unstable yield per tree, as well as oscillations in annual production. There is a large number of old (dilapidated) trees are involved in production, as well as plum orchards planted on inadequate land, resulting in irregular bearing rate and poor productivity. Current production could be achieved from smaller areas than it is the case at the moment, which could result in larger territories for other cultures.

Plum is grown on the territory of entire Serbia, but traditional regions of plum growing are the west of Serbia, Šumadija. The biggest issue in plum growing is represented in illnesses. The most important one is the plum pox virus, which decreased our production by ten, and to which the type called Požegača is particularly sensitive.

Apples come second according to land they are planted on, as well as by production, which has been growing in the last several years in Serbia. It is a very significant fruit species and represents a great part in total value of agricultural production. No species of fruit can bring such an income as apples can, if they are grown according to certain standards using certain technology of production (Statistical annual of the Republic of Serbia, 2012). Growing apples is profitable because it secures profit and accumulation to the producer, but only if sorts are adequately chosen on adequate soil and all that is grown in adequate ecological conditions using high technology. Contrary to that, the results are poor or there are no results. It is spread almost on every continent in uneven conditions, which means that it is easily adjustable to a change in environmental conditions. The existence of very well elaborated conditions of preserving its fruits and the difference in periods of its ripening supplies the world market with fresh fruits of apple continuously.

Very convenient climate conditions of our country enable a successful production of quality fruits of apple sorts. The economic significance of apple growing lies in versatile use of its fruits, because they are used through the whole year. Apples are significant in its nutritional, hygienic, diet-prophylactic and diet-therapeutic values.

Serbia is a large consumer of apples and, according to the data of the Republican Bureau of Statistics, this fruit species is in the first place by its consumption, with an average consumption of about 20 kilograms per citizen. A large amount of apples is processed and it is mainly juice. Serbia is a net exporter of apples, and the biggest share in export is

exactly fresh apple and juice. The greatest improvement has been made in export of this species, so that there can be noted its growth. What contributed to its growth is a continuously growing number of apple producers associations which export their products themselves. The largest part of export is directed towards Russian federation.

An increase in the territories planted with cherries has been noted in Serbia since 2000. Cherry occupies the third place according to lands planted with fruit in Serbia. It is among the oldest fruit species which have been grown from the ancient times, along with cherry. It is industrial fruit species because its fruits are intended for processing. They are used to produce syrup, juice, jam, compote, candied fruit and various desserts. Its fruits can be dried or deeply frozen and certain sorts have fruits which can be eaten fresh. They are used to produce liqueur and cherry brandy, and in confectionery industry to fill chocolate candies.

The economic significance of cherry is derived from its characteristic to bears fruits early and secures regular, high and quality yields. Because of its quality, cherry coming from our country is much respected raw material on the European and world market. In our country cherry comes third, behind plums and apples, according to production. Annually we produce about 100,000 tons of cherry. The number of trees has multiplied by more than eight in the last decades.

According to the data from the Republic Bureau of Statistics, strawberry-like fruit also represent a very important agricultural export article in Serbia. Raspberry production is primary when this species of fruit is in question. Natural conditions of growing raspberries are related to the area of west and central Serbia, but it has been spreading to other areas as well, because of its good prices and high standing.

There has been noted a growth in the territories planted with raspberries in Serbia after 2000. Out of total produced amount of raspberries in Serbia, a very small part is intended for domestic market as fresh raspberries, whereas the largest part is processed into frozen raspberries (rolend whole, grits, block, bruh, original) and are exported as such. Fresh raspberries are exported in a very small extent. Raspberries are mainly exported to the countries of the European Union (Germany, France, the Netherlands, Austria, Italy), whereas if countries in our immediate surrounding are in question, it is exported to Bosnia and Herzegovina and Croatia. Serbia exports almost 90% of its production.

Table 3. *Production of strawberry-like fruit (t) in Serbia, from 2007 to 2012*

Sort	2007	2008	2009	2010	2011	2012
Strawberry	33.129	37.924	35.799	32.973	31.161	20.000
Raspberry	76.991	84.299	86.961	83.870	89.602	50.000
Blackberry	30.000	10.000	14.000	15.000	17.000	15.000
Currant	100	120	130	150	180	250
Blueberry	-	-	20	50	100	150
Aronia	-	-	100	100	100	100

Source: *FAO stat/crops/and Republican Bureau of Statistics*

The significance of raspberry lies in the fact that fruits ripen very early which results in a faster return of the money invested, as well as the possibility of growing it in mountainous areas, planting material is easily produced and the techniques of growing and protection are not complicated. However, raspberry production is usually followed by certain problems, such as the need for employing a large number of workers to pick, which represent at least 25% of production expenses, very often, there is inconvenient production organization, storage, processing and traffic, unstable price for purchase, etc.

Statistically, Serbia had over 7,500 hectares of strawberry plants and yields of over 30,000 tons from 2007 to 2012. In the group of strawberry-like fruit, strawberry has a very important place. Besides cherries, strawberries ripen early; they are very attractive because their organoleptic characteristics, appalling appearance and harmonic sweet-sour taste. These fruits successfully influence the development and health state of human organism, thanks to valuable chemical structure. Besides fruit, others organs of strawberries are also significant (root, leaf), because they can be used to make tea which helps with high blood pressure, high level of blood cholesterol, kidney and urinary illnesses.

Strawberries are profitable fruit, especially if grown under plastic foils and near big cities. It bears fruits very early and can give large yields per surface unit (20 tons per hectare). It can be grown on higher elevations. It is resistant to many illnesses and pests. It is resistant to low temperatures. It is typical industrial species. However, its economic significance is diminished by poor transportability of fruit and the fact that it requires employing a large number of people for picking. It is spread on all the continents and grown in larger or smaller amounts. Very good prices and

high demand on world market positively influence the increase in production of this fruit in our country.

When blackberry is in question, Serbia is fourth in the world. Territories are estimated to around 5,000 hectares, and yield is around 15,000 tons and it is of exceptional quality. Due to its biological value, fruits are convenient to be used fresh, frozen and subject to various types of processing (juices, pulp, jams, wine, brandy, and candied fruit). Blackberries are very profitable. It is easy to multiply and grow. It bears fruits early, regularly and very abundantly. Most of the sorts ripen in August. It is easily adjustable to various climate and soil conditions. It is more resistant to drought and frost than strawberry and raspberry. Most of its production is exported frozen, while the rest is processed in domestic industry.

State of foreign trade fruit exchange, export chances and directions of future development

Foreign trade exchange of agricultural and food products are continuously rising. A significant rise occurred in 2006, but it has not been significantly accelerating since 2012. Achieved foreign trade exchange in 2016 was on the same level as in 2013, which was 3.3 billion euro (export was 2.1 billion euro, while import was 1.2 billion euro). Comparing to 2004, export value of agricultural and food products was larger by 3.3 in 2013, whereas the value of import was multiplied by 1.7. The level of import coverage by export of these products was 175% in 2013 (Ministry of agriculture and environmental protection, 2013, p.29).

In 2014 and 2015 a more significant increase in Serbian export in this area was noticed. Data of the Republican Bureau of Statistics of Serbia show that the balance of exchange in agriculture and food industry of Serbia with foreign countries in 2015 achieved export value was 2.579 million euro, which represents an increase of 11.3% comparing to 2014, whereas import value of 1.341 million euro represents an increase of 2.8% comparing to the previous year. Surplus in foreign trade exchange of agricultural and food products in 2015 showed an increase of 22.3% and now it amounts 1.238 million EUR.

The most important agrarian products in export during 2015 are mercantile corn, frozen raspberry, fresh apples, sugar refined from sugar beet and mercantile wheat.

According to Standard international trade classification, what are dominant in export are goods groups: fruit and vegetables, with a share of 5.5% in total goods export, wheat and wheat-based products, with a share of 4.8% of total goods export. Serbia exported 454.444 tons of various fruit to all corners of the world, which brought a total income of 583.40 million dollars in 2015. Viewed in quantity, it is 16% more than in 2014, when, according to Serbian chamber of commerce, an export of 391.930 tons and income of 552.40 million dollars were noted.

Speaking of fruit types, the greatest income in 2015 was brought by raspberries; both fresh and frozen, because by export of 100.233 tons an income of 280.61 million dollars was secured. Leading purchasers were from Germany, France, Belgium, Sweden and Austria. Apple placement (178,414 tons to Russian Federation) brought an income of 102.09 million dollars, fresh and frozen cherries (26,539 tons to Germany, RF and France) brought 31.42 million, fresh and frozen strawberries (8,889 tons to RF) brought 16.35 million and 4,602 tons (RF) brought 7.34 million dollars.

Leading national fruit, unfortunately, is not in this selected company, and it even noted a decrease in export of prunes from 6,000 to only 4,643 tons in the last year. On the other hand, our importers of fruit spent in 2015 less money (201.40 million dollars for 282,984 tons) than in previous year (215.52 million for 249,376 tons). The greatest amount of foreign currency – 62.82 million dollars was given last year for bananas (import of 44,098 tons from Ecuador and Columbia), followed by apples (17.75 million for 59,480 tons from Poland, Italy and Macedonia), oranges (21.77 million for 43,544 from Greece, Italy and Egypt), lemon from Turkey and Italy (17.79 million for 19,218 tons) and Turkish hazelnut (8.62 million for 699 tons).

Relatively convenient results of Serbian agriculture in foreign trade exchange were achieved thanks to advantages it has and achieved liberalization of trade, especially with the European Union, countries of west Balkans (CEFTA) and Russian Federation (signed in 2000, and ratified in 2001), as well as conjuncture, which is improving on the world market (increase in demand).

The most important partners of agriculture and food industry in Serbia, in addition to the EU and the Western Balkans (CEFTA) are signatories of the multilateral free trade agreements, as well as the market of the

Russian Federation with which Serbia has a bilateral agreement on trade liberalization. The aforementioned market in 2015 has a share in the total Serbian foreign trade of food 85.5%, out of which, their participation is 89.2% in total exports and their share is 78.4% in total imports.

Since 2001, Serbian agriculture has had a positive trade balance in trade with the EU. The surplus in the trade has a tendency of growth from year to year, so it was with 170 million dollars in 2001, increased to 1,027 million in 2014. The EU in 2015 was represented with 47.7%, while the share of imports in the structure of the EU put forward 63.7% in the structure of export of Serbian agriculture. The above developments are the result of reduced competitiveness of Serbian agriculture affected by falling export prices and rising protectionism in the EU market.

Balance of trade in agriculture and food industry of Serbia with CEFTA countries in 2015 shows the export value of 920 million dollars. At the same time, the value of imports was the amount of 173 million dollars. Surplus in foreign trade of agricultural and food products in the mentioned period amounted to 747 million dollars. CEFTA agreement enables market expansion and trade under the same conditions for all countries, opens up a larger market for investment and creating agencies to the competent management in this area. This agreement allows the Serbian businessmen sell goods free of duty in the market that includes about 30 million people, and at the same increases the chance to go to European markets.

Stronger presence in these markets implies a strategic concept of developmental and export-oriented agriculture, improving the competitiveness of agricultural origin of goods, raising the level of product quality and commitment to further liberalization of international trade. The concept of increasing exports of fruit and fruit products, in addition to stable and sustainable growth in production, requires an adjustment of the export structure requirements of import demands and improvement of the competitiveness of exports using comparative advantages in exports, in addition based on agro-ecological potential and technological modernization, improving the concept of education, management and organizational skills and experiences. Production and technological restructuring and productivity growth in fruit production, and greater competitiveness in domestic and international markets, should be based on environmental, energy and economic criteria. At the same time, the development of scientific research and the application of

existing and new knowledge and technology should enable a significant increase in the volume and cost of production. Strict implementation of the national program for the development of fruit production, food industry, as well as the overall development of the village, modern and industrialized fruit production and the food industry would constitute the basis of the rapid development of the entire economy and contribute to the faster development of other industrial sectors and infrastructure.

Increasing and diverse demands of our and foreign markets in terms of fresh and processed fruits, both in species and varieties, and new final products, is being followed by growth in increasing competitiveness. If we want to be competitive in this market, a better organization, a clear strategy, a revival of cooperatives and strengthening other forms of integration, more intensive cooperation between the state and all participants in the production are needed. It takes additional training, compliance of standards, more attention, more responsibility and work (Krstić & Stanišić, 2013, pp.151-167).

Production and processing of fruit can, as we have pointed out, be very profitable activities. However, in this respect, it is necessary to take appropriate steps towards the intensification of fruit production, as well as modernizing and specializing processing capacities, so that our fruit products would be able to meet the quality requirements of the most choosy world market. It is necessary to carry out a gradual modification of the production structure in favour of deficient fruit species that have the greatest chance of realization in the world market. Shortage fruits (apricot, peach, apple, cherry, pear, berries and nuts) are most likely to export a quality preparation for market fruit (fresh, chilled and processed, and processed in appropriate ways) is also an important basis for improving competitiveness of fruit production in the continent. In recent years as one of the most important sources of competitiveness of the agricultural sector the creation of brands or brands is mentioned. In this regard, it is important to point out the significance of making efforts to create a brand out of existing products of our area that can be competitive on the world market. To succeed in this, it is necessary to develop a branding strategy, improve the level of processing of the products and their packaging. When traditional products are in question, it is necessary to work on the protection of geographical origin of the product and branding of certain regions and areas. In addition to the registration of the brand of geographic origin, it is necessary to improve and strengthen marketing activities and additional promotional activities by the state authorities.

Conclusion

To continuously achieve high rates of economic growth and a constant increase in gross domestic product and the standard of living, the Republic of Serbia must constantly and rapidly increase their exports. The increase in export revenue is an important condition for servicing high levels of external debt and provides financing for the import of equipment and technology, and that means a prerequisite for economic development in the forthcoming years. In this sense, the agricultural sector has a very important role. Creating competitive agricultural market, in particular the market in fruit, can greatly contribute to the strengthening of export potential of the domestic economy. In order to increase the competitiveness of fruit and fruit products, conformity in producing attractive and unique product, characteristic for our area must be taken into account. It is therefore necessary to carry out technological modernization of fruit production, adopt modern standards and produce quality products that meet the demands of the market.

Literature

1. Babić, J., Mitić, S., Gligorijević, M. (2012), *Unapređenje izvoza hrane iz Srbije*, Marketing (1), Beograd.
2. Cvijanović, D., Ignjatijević, S., Milivojević, I., Mihailović, B., (2016), *Potencijali Srbije u međunarodnim okvirima - značaj poljoprivrede i zdravstvenog turizma*, Monografija, Fakultet za hotelijerstvo i turizam u Vrnjačkoj banji.
3. Cvijanović, D., Popović, V., Subić, J., Paraušić, V., (2013): *Stanje i mogućnosti razvoja održive poljoprivrede i ruralnog razvoja u podunavlju*, Monografija, Institut za ekonomiku poljoprivrede Beograd.
4. Đurić, D., Ristić, J., Đurić, Dragana (2016): *Foreign Direct Investments in the Role of Strengthening the Export Competitiveness of the Serbian Economy*, Economics of Agriculture, Vol.LXIII, N2(357-740), 2016, ISSN 0352-3462, Belgrade.
5. Gulan, B (2010): *Organska poljoprivreda i hrana*, Agropress, 45.

6. Gvozdenović D., Curaković M., Lazić V., Vujičić B., Vračar LJ., Dimić N. (1997): *Berba, pakovanje, čuvanje i prerada voća, Jugoslovensko voćarstvo*, Vol. 31, br. 119-120, Čačak.
7. Izveštaj o stanju u poljoprivredi u Republici Srbiji u 2013. godini, Republika Srbija, Ministarstvo poljoprivrede i zaštite životne sredine, Beograd.
8. Krstić, B., Stanišić, T. (2013): *Uticaj unapređenja ekonomije znanja na konkurentnost zemalja jugoistočne Evrope*, *Indistrija*, 41(2).
9. Kvartalni monitor br. 40, 2015, Beograd.
10. Milić D., Radojević, V., (2003): *Proizvodno-ekonomska i upotrebna vrednost voća i grožđa*, Poljoprivredni fakultet, Novi Sad.
11. Ministarstvo finansija Republike Srbije (2011): *Strategija povećanja izvoza Republike Srbije za period od 2008. do 2011. godine*, Beograd.
12. Munćan P., Živković D. (2004): *Menadžment rada i proizvodnje u poljoprivredi*, Poljoprivredni fakultet, Zemun.
13. Nikolić, D., Keserović, Z., Magazin, N., Paunović, S., (2012): *Stanje i perspektive razvoja voćarstva u Srbiji*, Zbornik radova 14. Kongresa voćara i vinogradara Srbije, Naučno voćarsko društvo Srbije, Čačak.
14. Prokopović, B., Prokopović, T. (2011): *Brend kao naša sudbina*, *Ekonomika* 57.
15. RSZ, Statistički godišnjak Republike Srbije 2012. godina.
16. Zlatković B. (2003): *Tehnologija prerade i čuvanja voća*, Poljoprivredni fakultet, Zemun.

APPLICATION OF NEW TECHNOLOGIES AND PRECISION AGRICULTURE¹

Ferhat Čejvanović², Vladimir Filipović³, Adnan Kamerić⁴

Abstract

Precision agriculture is a concept of integrating new technologies, supported by information systems and agricultural industries. Accordingly, it represents an integrated management system that is supposed to harmonize production materials with the optimum needs of agricultural crops. A special contribution of precision agriculture lies in combining information and technology for the purpose of identifying a proper management system of the cultivation of agricultural crops, optimizing profits, and it particularly affects the protection of natural resources and land. It is particularly important that new information technologies are helpful in making better decisions on various aspects of agricultural production. The aim of precision agriculture is to optimize the management and distribution of inputs, but taking into account the specifics of each locality with the increase in production efficiency. The fact is that farmers who effectively use the information provided by precision agriculture achieve higher yields and effects than those who do not use the advantages and possibilities of precision agriculture.

Key words: *new technologies, precision agriculture, integrated management system*

¹ The paper represents a part of the research results within the Project of Integral and Interdisciplinary Research No. 46006 “Sustainable Agriculture and Rural Development in the Function of the Accomplishment of Strategic Objectives of the Republic of Serbia in the Danube Region”, financed by the Ministry of Education, Science and Technological Development of the Republic of Serbia.

² Government of Brčko District of Bosnia and Herzegovina; External Associate of the Faculty of Economics, the University of Tuzla, Mostarska 195 (195 Mostarska Street), Brčko, Bosnia and Herzegovina; e-mail: ferhat.cejvanovic@gmail.com.

³ Vladimir Filipović, PhD, Research Associate, phone: +381(0)13 377-855, e-mail: vfilipovic@mocbilja.rs, Institute for Medicinal Plants Research “Dr Josif Pančić”, Tadeuša Košćuška 1 (1 Tadeuša Košćuška Street), 11000 Belgrade, Serbia.

⁴ Doctoral Student, the “Vitez” University, Travnik, Bosnia and Herzegovina.

Introduction

The growth of the human population in the world is increasing the demand for agricultural products, but, at the same time, there is a decrease in the ability to satisfy the demand due to the reduction of agricultural land, as well as various instances of climate change. A solution imposes itself in the form of a new approach called precision agriculture. The fact is that agricultural production is increasingly becoming an activity in which new technologies are applied, using equipment and agricultural machinery. More and more farmers in the world are beginning to use the machinery based on new technologies. Thus, new tractors can locate agricultural plots, operate driverlessly, and always move precisely and accurately in the string of processing, care and harvest. In addition, new agricultural technologies include various types of sensors that collect a variety of necessary information concerning the levels of nutrients or moisture in the soil. Precision agriculture is an integrated management system that attempts to harmonize the type and quantity of inputs to the real needs of crops on small areas within arable land. This intention is nothing new, but new technologies are now available, and allow the concept of agricultural precision in order to achieve the desired objective of practical production. Precision agriculture is generally defined as (1) information and the technology based on: (2) identifying the management systems for growing, (3) the analysis and management of variabilities in the arable land area for the sake of optimum profitability, sustainability and protection of land resources. In this mode of cultivation, new information technologies can be utilized so as to make better decisions on many aspects of the production.

The basic premise of precision agriculture is to make the increasing body of information, including the precise items of information, available to farmers on the occasion of decision-making. A direct comparison of perennial parameters obtained from land plots results in a more and more trustworthy, reasoned and optimal use of the means of work, taking into account the environmental impact, which will increase the quality and quantity of products. Nowadays, the development of satellite navigation and monitoring technology in agricultural machines, and the reduction in the cost of that gadgetry raises the question of the application of precision agriculture. Progressive agricultural farmers in agriculturally developed countries already apply some of those technological opportunities of precision farming on a regular basis (Pavlović, 2015).

New technologies in the form of precision farming are tasked to provide answers to global needs for food, as well as to solve the problems of environmental pollution. The intention of farmers is to use new technologies with the aim to produce larger quantities of higher quality products, but with a cutback in production costs and with reduced environmental pollution. The basic objective of this paper is to review the research studies concerned with precision farming, and present the economic effects of the application of precision agricultural production. The methods used in the research are as follows: desk research, descriptive methods, the methods of analysis and synthesis, as well as the methods of induction and deduction.

Concept of “precision agriculture”

The term “precision agriculture” or “precision farming” implies the timely performance of agricultural work, high productivity, a reduced number of operations and the lowest cost of labor, and is based on the newly developed computerized technical systems of programmed exploitation potential, a small number of machines of high reliability and high technological capabilities (Jurišić and Plaščak, 2009).

The basic presumption of precision agriculture is the availability of a large number of precise information available to the farmer in making decisions. A direct comparison of perennial parameters results in an optimal use of the means of work, taking into account the environmental aspect (Jurišić et al., 2015).

The timely of agricultural works, with high productivity and low cost of work, stemming from the reduction in the number of operations, is the briefest description of “precision agriculture”. With the introduction of high and sophisticated technology systems in agricultural machinery, arise the possibilities of achieving a high quality of the end product, as well as high competitiveness (Jurišić and Plaščak, 2009).

Precision spaced planting is a widespread technique in the domain of precision agriculture. In the past, there were a number of solutions that were supposed to solve the problem of overlapping plots and/or croplless soil during mechanization. The rapid development of new technologies has created the conditions for the solution to this problem in an economically viable manner. Regardless of the technique of precision agriculture, the technology that is indispensable and makes an integral

part of all the techniques is called the GPS technology (Pavlović, 2015). Precision agriculture involves spatial management of the means and production materials of agricultural production in order to increase profits, yield and product quality. Primarily, it is about sophisticated equipment that is installed in agricultural machines during the processing of soil, as well as the care and protection of agricultural crops.

The opportunities that precision agriculture delivers in terms of economic and environmental benefits lie in the reduction in the use of water, fertilizers and pesticides. Instead of managing an entire field on the basis of hypothetical, average conditions, which may not exist anywhere in that particular field, through the approach of precision agriculture, one can recognize the variables within a specific location or a specific spots in the fields, and thus, the management operations are adjusted in accordance with such diversity (Singh, 2002).

Precision agriculture provides the possibility of automatic and simplified data collection and analysis. It makes possible to make managerial decisions and to implement them fast on small areas within larger fields. Precision agriculture serves the economic and environmental improvements, for example, the saving of the means of production, the saving of labor and of the use of agricultural machines, less working hours, the reduction of environmental burdens, etc. To achieve those goals, it is necessary to comprehensively collect and process various information. The data derived from the observations of a single characteristic are immediately processed. That is where their information content is processed according to the information on the cultivation of plants. What follows is the transfer of the data obtained. Most modern agricultural machines can offer the direct documenting of a performed procedure. The appropriate use of information and time relations is what makes a difference when it comes to precision farming principles.

Precision agriculture has certain procedures and working operations which consist of: tillage, sowing, fertilization, crop protection, yield mapping, nutrient mapping, soil type mapping, etc. (Pavlović, 2015).

Precision agriculture and plant protection allow a farmer to achieve high yields, while preserving natural resources. Using the modern technology of geographic information system (GIS), machines collect data directly from a plot using sensors, and thus, get integrated into data processing systems. The farmer uses the processed information through the means of

the GreenStar system for newly planned operations and achieves substantial savings of time and finance. Precision agriculture offers the possibility of the optimal care for every single plant, and not just the average care, that is, the care of the field as a whole. A low investment risk is one of the main factors in the choice of precision agriculture. By the use of unmanned aircrafts, remote sensing enables fast and cost-effective data acquisition and the information of satisfactory accuracy, and using modern technologies such as Variable Rate Application and GreenStar software package, it is possible to regulate the amount of care and protection (Jurišić et al. 2015).

There are a number of new techniques through which the principles of “precision agriculture” are accomplished. These are just some of them:

1. precision spaced planting - guidance of agricultural machinery with the help of GPS,
2. technology of variable norms,
3. yield mapping,
4. remote detection,
5. geo-information system (data processing and analysis).

Modern devices utilized in agriculture are controlled electronically, and are easy for networking (Zogović and Dimić, 2008). The purpose of networking is having a number of technical devices tied into the system, which should meet all the requirements in precision agriculture. On the occasion of agricultural operations, the collected information is used to determine a specific position so as to know the amount of the needed production materials for a particular spot, and not, on average, for the entire agricultural plot. In the cultivation of plants, most of the processes take place relying on data collection sensors, data processing and the consequent taking of certain agricultural practices.

The applicability of GPS guidance in agriculture has reached a high degree in practice because of the increasingly lower costs of equipment and costs of the application (Martinov et al., 2008). The introduction of GIS (GPS) technologies in agricultural mechanization marked the beginning of the development of precision agriculture. The inputs are optimized and the outputs are defined to satisfy the consumers in real time (Jurišić et al. 2015). The interconnection of GIS tools in precision agriculture is shown in Figure 1.

Figure 1. *Interconnection of GIS tools in precision agriculture*



Source: *Rajković, 2013; Jurišić et al., 2015*

By the use of the GIS system, the inputs are optimized and the outputs are defined to meet the consumers' needs in real time. The GIS technology helps unify data for analysis and production planning, as well as mapping and informative report on the soil and the cultivated variety. The use of electronics and computers, i.e. sensors, actuators, various communication courses, managerial and control switches and microprocessors makes agricultural information technology (AIT). By using modern technology such as Variable Rate Application and GreenStar, it is possible to regulate the amount of care and protection (Figure 2).

Figure 2. *Application with a variable amount of pesticides*

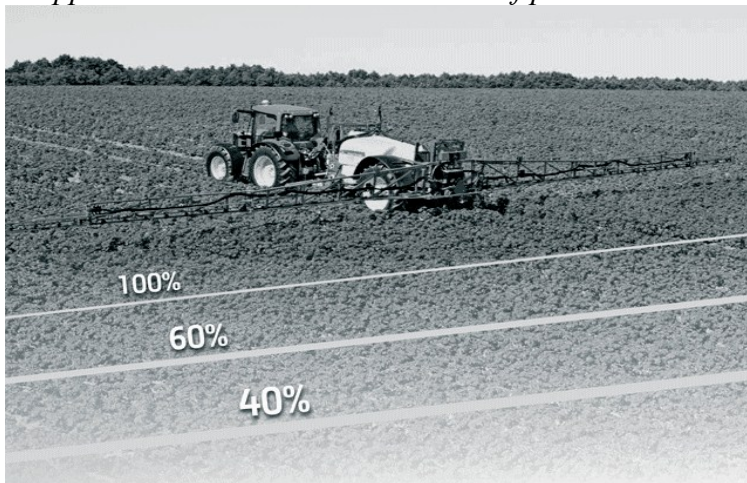

Source: *Rajković, 2013; Jurišić et al., 2015*

The GreenStar system allows the optimisation of the work, and facilitates the full documentation of agricultural production, and this optimization consists of certain components (Jurišić et al. 2015).

Agricultural Machinery - Equipment in precision agriculture

The large and constant need for food has caused the progressive development of technology in agricultural production, and thus the development of the means of agricultural mechanization - of machines. The emergence of increasingly advanced and more sophisticated machines require their optimum use, which is a prerequisite to achieve greater labor productivity and with the aim of cheaper food. Modern equipment of agricultural farms mechanization is characterized by rational furnishing properties in qualitative and quantitative terms, continuous monitoring of the development of new technologies and attempts to introduce them to the farm, organizing work in multiple shifts, and performing works in agro-technical period and the use of new management capabilities (Brkić et al., 2005).

Precision agriculture, in addition to the collected accurate information, requires the use of newly developed machine systems that are characterized by precision work. These agricultural machines are usually equipped with computers and the systems that allow the control and documenting of performed procedures. Though these machines and equipment are very expensive, it is important to recognize the role of these systems in agriculture, since the engagement in precision agriculture is impossible without high-quality agricultural machines.

The manufacturers of the equipment and systems that integrate into agricultural machines are increasingly devoted to the issues of possible upgrades and the compatibility of their system with the systems of other manufacturers. In this way, it is ensured that the computers, navigation receivers and equipment may efficiently be connected to the computing or control system of auxiliary machinery or other devices. This ensures the reduction in hardware prices in the cabins of agricultural machines, because it does not require additional investments in various circuits or computers that allow the connection with a system of agricultural machines, but also makes it possible to purchase some auxiliary devices with systems other than the specific one of the drive machine, and still achieve compatibility.

The term “agricultural information technology” (AIT) refers to the use of electronics and computers in the agrarian sector. The term “electronics and computers” encompasses sensors, actuators, communication sequence (serial bus systems), controlling and regulating switches, microprocessors, process computers, personal computers, agricultural software and telematics devices (Jurišić and Plaščak, 2009).

Auxiliary machines also allow the application of the technologies that dispense variable amounts of released materials at work in the fields, or enable automatic opening and closing of a dispenser, which significantly contributes to a more rational use of production materials and to environmental protection.

Rationalization, environmental, economic and energy effects represent an important point in the inclination towards and the selection of specific agricultural machinery. These indicators should be the basis for the planning of the equipping of agricultural holdings with mechanization. The methods and tools that contribute to better effects can be utilized in a variety of ways. Using highly productive aggregates, it is possible to preserve the soil, and to carry out a more economical and more environmentally sound production. The selection of the parameters and technological processes of the machinery should be based on the factors that affect the productivity, cost-effectiveness, energy efficiency and land conservation. Selecting a walking mechanism for the tractor, one can control soil surface trampling and soil compaction. By the increase in the working width of machines, in addition to the increased productivity, the percentage of soil trampling is significantly reduced. Using high power tractors in the conventional primary treatment, productivity can be increased by up to five times, while saving energy and reducing soil trampling. The use of joint aggregates in conventional tillage also contributes significantly to energy savings, increased productivity and reduced trampling (Pavlović, 2015).

The navigation agricultural machinery through the means of satellite guidance makes it possible to record the exact positions of agricultural machinery and equipment in agricultural areas, and to enable precise movement of machines while performing agricultural operations. The level of accuracy and precision depend on the quality and possibilities of the very navigation devices, but also, they often rely on the quality and precision of high accuracy signals. When we talk about the use of satellite navigation in agriculture, it is worth noting that the purpose of such

receivers is not a typical use, like that in the transport of goods or similar activities and industries, where such devices are used only as an aid for finding specific routes or specific addresses. Navigation receivers used in agriculture must meet the requirements of high precision, especially regarding automatically operated machines when carrying out agricultural operations where the required level of accuracy reaches up to a centimeter or less. In addition to the achievement of high precision, navigation receivers for agriculture are also characterized by other systems integrated into the computer-assisted navigation system, and which are typical of agricultural activities only, such as the management and monitoring of automatic section control, the utilization of the Variable Rate Application, the input and interpretation of data from digital agricultural mapping (the maps of the soil, yield, fertilization, etc.).

A management controller, in keeping with the position of a vehicle and relatively to the desired position, generates the appropriate control commands. The control system of the vehicle is a combination of hydraulic and/or electronic components, which puts the control wheels to an appropriate position. The control management system determines the current position of the vehicle, compares it with the desired position, and executes a proper management in order to put the vehicle in a desired position.

The system management of agricultural machines can be classified into three groups (Pavlović, 2015):

- a) assistance in managing,
- b) automatic control,
- c) autonomous system management.

The management assistance system is a type of system that provides an operator only with the information on navigation. Automatic and autonomous systems of management are designed in such a fashion that the adjustment of the control of the navigation mechanism takes place without a driver. The tracking of the path of auxiliary agricultural machinery is much harder than that of the vehicle itself, and therefore, the navigation systems for agricultural auxiliaries have special significance. The control systems for vehicles or auxiliary machines typically contain at least the following three elements:

- a sensor system that provides the information on changing the position of a vehicle or auxiliary equipment,
- a controller that provides the system with a specific corrective signal,
- an actuator which, combined with the control mechanism, changes the position of a vehicle or auxiliary equipment.

The systems developed for the automatic control of agricultural machinery were previously limited only to specific applications, since there was no single universal sensor system secured. However, at present, for the calculation of the position of a machine, as well as for the accuracy required when applied to inter-row cultivation, Real Time Kinematic (RTK) DGPS makes a suitable choice. The control system for agricultural equipment uses a digital map that contains all the coordinates necessary to describe specific paths for a machine in the field, a sensor to measure the actual position of the machine, a comparator to calculate an error in positioning, a controller to generate a corrective signal and an actuator, mounted between a tractor and a machine, to return the machine to a desired direction. The management system needs to be assembled as an open modular system. In the further development of the automatic tiller, the method of sensor grouping is accepted as a future solution. The principle of sensor grouping is to combine the information from different sources of sensors, since no individual sensor technology is ideal for the automation of vehicles in all the possible conditions of their use.

An important piece of the equipment of agricultural machinery make DGPS/GPS receivers, i.e. the navigation, which enables the display of the exact location of a machine in a field, shows the direction of movement and tillage, and makes possible the saving of production materials and time. Though not primarily designed as commercial systems to be used for civilian purposes, navigation technologies have found their way to agricultural producers. GPS and DGPS receivers are becoming an increasingly important component of the application of new technologies in agriculture, which is the basis of precision agriculture. The knowledge of the exact position in the field is a very important factor that contributes to precision in carrying out agricultural work. Although a GPS receiver can receive signals from several satellites simultaneously, it is important to emphasize that the exact GPS positioning requires signals from at least four satellites. The more satellites are able to transmit the signal to a GPS receiver, the greater the accuracy of positioning. The accuracy of the receivers of this kind is usually a few tens of centimeters, which satisfies

the need for precision in most operations. To maximize the accuracy of GPS receivers, a simultaneous reception of corrective signals from other satellites is needed (Pavlović, 2015).

Likewise, precision agriculture is an investment that is reflected in the purchase of the last generation agricultural machinery for all the phases of crop production from the sowing, through the nourishing, to the harvesting. Also interesting is the use of drone devices for the purpose of monitoring and filming agricultural land, with the possibility of detailed video and photo capturing of large areas of arable land of 100 or more hectares. The data collected from a drone is transferred to the GIS system, utilized by agricultural technologists in handling the data and doing the mapping of top dressing. The same information is entered into the computers of satellite guided tractors and according to them, the timely and accurate processing, care and harvesting of crops is executed. This means that the plant receives the necessary amount of fertilizer, neither more nor less than the optimum, which is defined by a computer program. In this manner, farmers protect the environment and achieve savings in the application of agro-technical measures, but what is also achieved are significant savings of time spent in walking through the fields and monitoring the state of the crops.

Economic indicators in precision agriculture

Although the term “precision agriculture” is today tied to certain new technologies used in the process of agricultural production, the key to precision farming is still the information obtained in the course of that production. It has been proven that manufacturers who have a managerial approach in the course of production, or, in other words, have an access to more detailed information, generate higher profits just as well. Agriculture must equally take into consideration both the economic and the environmental requirements. Precision agriculture serves economic and environmental improvements, primarily in:

- the savings of the means of work;
- the savings of the machinery and work hours;
- the improvement in making profits through higher yields and improved product quality;
- the reduction of environmental burdens and the encouragement of natural environmental conditions;
- the improvement of the documentation on production process.

Precision agriculture involves spatial management of resources and production materials in agricultural production in order to increase profits, yield and product quality. By the distribution of expenses related to specialized equipment across greater areas of used soil, and by the utilization of the skills and knowledge of experts in the field of precision agriculture, the costs can be reduced of regular and common services or jobs, whereas the efficiency of precision agriculture activities can grow. The main goal of precision agriculture is to increase profitability through the increase in yield and the reduction of the input volume/cost.

Modern agriculture in developed countries is faced with requirements to achieve the highest possible quality to produce at as low as possible costs and to make as little as possible impact on the environment. The application of precision agriculture in the management of the guidance system of agricultural machinery enables the fulfillment of demands in terms of yield increase and cost reduction.

The rapid progress in electronics, computer science and computer technologies has inspired a renewed interest in the development of vehicle management systems. The present proposals are mainly based on computer vision and satellite positioning (Karadžić et al., 2007).

From a more precise machine guidance by direction result direct benefits and savings, loss reduction and the reduced damage to plant mass, as well as a better structure of the product. If we observe farm work operations aimed at the reduction of the number of walkthroughs per plot, what derives are direct benefits and cost savings, the reduction of agricultural inputs, reduced fuel consumption, improved environmental conditions, the improvement of ergonomic conditions and the increase in labor productivity (Mago, L. 2009). Research by Marković et al. (2012) was conducted at the Agricultural Corporation Belgrade (the PKB), where the production process was followed, and on which occasion, the budget calculation of five most abundant species was executed, namely: mercantile corn / silage corn (totaling 6,573 ha), mercantile wheat / mercantile barley (totaling 6,049 ha), mercantile soybean (totaling 2,384 ha), sugar beet (totaling 1,247 ha), alfalfa (totaling 2,705 ha). According to Marković et al. (2012), the savings (economic profit), which is achieved by the use of satellite positioning and automatic control, is not the same for all the plant species and all the applied agro-technical measures, i.e., production technology. In calculating the potential savings in production on the agricultural holding (the PKB), the used data were taken from its own records.

The calculation of potential savings in the production of mercantile and silage corn with the use of satellite positioning and automatic control of tractors and other machines was carried out according to the field history data of the PKB on the agricultural holding of Lepušnica, which is in Belgrade's suburban area of Glogonjski Rit, and covers an area of 90 hectares. In the named field, corn is used for silage, though the budget calculation would be identical if corn was used for cob harvesting or threshing. The savings in corn production with the use of satellite positioning would primarily be achieved in the following operations (Marković et al. 2012):

1. discing, which provides the most significant effect in the reduction of overlapping, and therefore, in the reduction of the amount of fuel consumed. The estimated saving on this plot is 96.43 euros, or 1.07 euros per hectare, for this operation,
2. the distribution of mineral nutrients by aircraft, which also provides the most significant effect in the reducing of overlapping, and, at the same time, the reduction of the amount of dissipated mineral nutrients and the amount of fuel consumed. The estimated saving on this plot is 534.20 euros, or 5.93 euros per hectare, for this operation,
3. the distribution of mineral nutrients with manure spreaders, which is another way of providing the most important effect in the reduction of overlapping and the reduction of the amount of dissipated mineral nutrients, as well as the amount of fuel consumed. An additional advantage may be the possibility of location-specific distribution. The estimated saving on this plot is 427.83 euros, or 4.75 euros per hectare, for this operation,
4. soil preparation for sowing, whose most important effect is to reduce overlapping and the amount of fuel consumed. The estimated saving on this plot is 86.33 euros, or 0.96 euro per hectare, for this operation.

The above mentioned operations are precisely what is taken into account when calculating the savings. The accuracy of the positioning signal does not necessarily have to be highly accurate, and the control can be manual, just as well.

What follows are the operations which require the most accurate signal and indispensable automatic control of the tractor in order to achieve the desired effect, especially in maintaining precise direction (Marković et al., 2012):

1. sowing, the most significant effect in maintaining direction and the equidistance and parallelism of lines, which allows a proper structure of

plants on the plot and the subsequent conduct of the tractor in traditional operations after the sowing traces,

2. protection by sprinkling, along with the conducting of the tractor after sowing traces, allows a more comfortable operation for the operator, and combined with the possible implementation of location-specific protection, brings about savings and environmental protection,

3. inter-row crop cultivation, along with the conducting of the tractor after sowing traces, prevents the damage to the plants from the operating parts of a cultivator, and, eventually, the loss of plants.

In the following operations in corn production, the application of satellite positioning does not have a particularly considerable impact:

1. ploughing,

2. silage/harvesting.

The total potential savings on this plot amount to 1,144.79 euros, or 12.72 euros per hectare.

Real savings for the five most abundant crop varieties on the agricultural holdings of the PKB slightly vary around the calculated, which is the result of various forms of plots, but the tendency is noticeable towards the increase in savings in keeping with the increase in the width of a plot in relation to its surface. Knowing the structure of the sowing and the calculated savings per hectare, it is possible to calculate the savings by culture and the overall savings for the five named crops (Marković et al., 2012).

As a final result of the analysis of potential savings in the use of satellite positioning on the agricultural holdings of the PKB, and with the automatic control of tractors and other machines, the grand total sum is obtained of 301,980 euros per season. The average savings per hectare of sowing structure in the 2009/2010 season was 15.92 €/ha. This represents the direct savings in inputs and fuel.

Certainly, one should also bear in mind the increase in productivity, the possibility of cost savings due to the potential practicing of night work with the aid of satellite positioning, the possibility of realizing the concept of precision agriculture through management, accounting, miscellaneous documentation and the production planning for upcoming periods, the improvement of working conditions for machine operators, and finally, the possibility of the contribution to environmental protection (Božić et al., 2010).

The costs of device purchasing and procurement are invariable. Regardless of the exploitation indicators of purchased equipment, the costs of the devices at the annual level remain the same. On the other hand, the costs of the devices, expressed per unit area, decrease with the increase of the surface on which they are applied (Marković et al., 2012).

A navigation device or a complete system that is used for tractor navigation and control is cost-effective in the application to an area where the costs are lower than the projected potential savings. With the growth of an area processed by using satellite navigation devices, the costs per unit decline. At the same time, one needs to keep in mind how many hectares can be handled by a single tractor on annual basis. Different tractors are used for different operations.

Assembling/dismantling devices can be moved from one tractor to another, but, if some operations are taking place simultaneously, the acquisition of two or more devices is necessary, which affects the economic indicators (Marković et al., 2012).

By the use of modern systems, precision agriculture makes an extraordinary and significant impact on agriculture, in particular, when it comes to the economic aspect. Thus, the advantages of using those modern information technologies are obvious, and the intensity of the adoption and implementation of those systems grows day in, day out. In order to make the GIS tools and the GPS systems even more integrated, it is necessary to raise the level of IT skills, and each operator must individually decide to invest, not only in equipment, but also in themselves through various aspects of the education about informational technologies, without which modern systems cannot have full efficiency in their exploitation (Jurišić et al., 2015).

Conclusion

New breakthroughs in the field of agricultural engineering and mechanization introduce new technologies. On this basis, it is important to note the role of new technologies in the improvement of agricultural production and the making of optimal and timely decisions. Precision agriculture is based on the optimization of production materials (inputs) and yield. This approach to agriculture implies the use of satellite systems such as GPS and the Internet, in order to manage the production, but also, to reduce the dosage of fertilizers, pesticides and water.

Farmers who use precise data can make better use of inputs (pesticides and fertilizers), which contributes to the protection of soil and watercourses, as well as to the increase in the efficiency of agricultural production. Using the equipment and machinery from the domain of precision agriculture, agricultural producers can identify the localities of agricultural plots that need special treatment, and are able to take appropriate agro-technical measures. This approach is partly in contrast with the traditional approach of agricultural production, in which the measures such as irrigation, fertilizing, insecticide and herbicide spraying are applied on all agricultural land regardless of needs.

The main goal of precision farming is to improve yields, reduce costs, and reduce the risk of environmental pollution.

The essence of the application of precision farming is primarily reflected in the monitoring of soil parameters and of physico-chemical parameters of plants. This is achieved by the use of sensors (electrical conductivity, nitrates, temperature, evapotranspiration, radiation, leaf and soil humidity, etc.), which brings about the optimum conditions for plant growth. From the economic point view, precision agriculture provides the ability to receive information for making optimal decisions on the management of agricultural production.

In addition, precision agriculture reduces the costs of the application of fertilizers and chemicals, while reducing environmental pollution through the reduced use of chemicals. Also, the application of precision agriculture provides data on agricultural production, which are essential in the stage of the sales of agricultural products. It is worth noting that, in the process precision farming, software can also be integrated in order to manage agricultural production with the purpose of facilitating the performance of all activities on a farm and increasing labor productivity. Neither are negligible the benefits such as: lower fuel consumption, less soil compaction, less labor investment and the timely application of agro-technical measures.

Experience shows that precision agriculture has contributed to an increase in crop yield and uniformity through the application of optimal technology under each plant. Finally, it is important to point out that farmers who use the benefits and opportunities of new technologies in precision agriculture ultimately increase their profits.

Literature

1. Božić, M., Topisirović, G., Kalanović-Bulatović, B. (2010): *Primena GIS tehnologije u poboljšanju ratarske proizvodnje na teritoriji grada Beograda/GIS technology application in improvement of the Belgrade area crop production*, Poljoprivredna tehnika, 35(2), 79-88.
2. Brkić, D., Vujčić, M., Šumanovac, L., Lukač, P., Kiš, D., Jurić, T., Knežević, D. (2005): *Eksploatacija poljoprivrednih strojeva/ Exploitation of agricultural machinery*, Poljoprivredni fakultet Osijek, Osijek.
3. Jurišić, M., Šumanovac, L., Zimmer, D., Barač, Ž. (2015): *Tehnički i tehnološki aspekti pri zaštiti bilja u sustavu precizne poljoprivrede / Technical and technological aspects in plant protection in the precision farming system*, Poljoprivredni fakultet u Osijeku, Časopis „Poljoprivreda“ broj 21. (2015/1), 75-81.
4. Jurišić, M., Plaščak, I. (2009): *Geoinformacijski sustav, GIS u poljoprivredni i zaštiti okoliša/Geographic Information System, GIS in agriculture and environmental protection*, Poljoprivredni fakultet u Osijeku.
5. Karadžić, B., Malinović, N., Meši, M., Mehandžić, R., Turan, J., Anđelković, S. (2007): *Automatsko vođenje mašina pri međurednoj obradi ratarskih kultura / Automatic control machines for inter row tillage field crop culture*, Savremena poljoprivredna tehnika, 33(3-4), 187-195.
6. Mago, L. (2009): *Smanjenje troškova mehanizacije sa primenom GPS u ratarskim proizvodnjama/Reducing the cost of machinery with the implementation of GPS in crop production*, Poljoprivredna tehnika, 34(2), 91-95.
7. Martinov, M., Gavrić, M., Ferenc, K., Brunet, B., Micković, G., Veselinov, B., Bojić, S. (2008): *Primjenjivost GPS navođenja/ Applicability of GPS guidance*, XXXVII. međunarodni simpozij „Aktualni zadaci mehanizacije poljoprivrede“, Opatija, 201.-212.
8. Marković D., Krstić D., Simonović V., Marković I. (2012): *Analiza ekonomskih pokazatelja u primeni GPS tehnologije u*

poljoprivrednom kombinatu Beograd/Analysis of Economic Indicators for Application GPS Technologies in Agricultural Corporation Belgrade, Poljoprivredna tehnika, XXXVII(4), decembar 2012, Poljoprivredni fakultet Beograd, Institut za poljoprivrednu tehniku, 79 - 88.

9. Pavlović Nikola, (2015): *Tehničko - tehnološki činitelji sjetve i sadnje primjenom GIS tehnologije - precizna poljoprivreda/ Technical - technological factors of seeding and planting by GIS technology - precision agriculture*, Diplomski rad, Sveučilište Josipa Jurja Strossmayera u Osijeku, Poljoprivredni fakultet u Osijeku.
10. Rajković, I. (2013): *Primjena geoinformacijskih sustava i precizne poljoprivrede pri zaštiti bilja/Application of GIS systems and precision farming PRI Plant Protection*. Diplomski rad, Sveučilište Josipa Jurja Strossmayera u Osijeku, Poljoprivredni fakultet u Osijeku.
11. Zogović, N., Dimić, G. (2008): *Zahtevi i tehnološke mogućnosti komunikacionih sistema u preciznoj poljoprivredi / Requirements and technological capabilities of communication systems in precision agriculture*. XVI telekomunikacioni forum. Konferencija TELFOR, Beograd.

ROLE OF THE BUDGET IN FINANCING OF AGRICULTURE

Ivan Milojević¹, Mihailo Ćurčić²

Abstract

Financing the development of agriculture is one of the basic tasks of a condition of economic growth of any country. Focusing on the financial institution budgets may be present level of need and the possibility of meeting the basic social needs, with the aim of establishing and functioning of agriculture as primary branch of the economy in the Republic of Serbia. Using statistical methods present the causal relationships between the elements of financing agriculture and their main financial strongholds, the economic power of the state, with reference to the agricultural sector of the Republic of Serbia.

Key words: *budget, agriculture, financing.*

Introduction

Agriculture is the primary economic activity that has economic, social and political significance. The market developed economies, agriculture has an essential character, whether we are talking about agriculture in the narrow sense as primary the agricultural production, or in a broader sense as a multifunctional economic activity.

Therefore, the budget provides support board development of agriculture, through the financing of satisfying the needs of the agricultural sector.

Financing is the basic factor for the survival and development of business systems, and if present agricultural system as it is and funding directed towards it.

¹ Ivan Milojević, PhD, Military Academy, Pavla Jurišića Šturma 33, tel. 060/0702697, drimilojevic@gmail.com.

² Mihailo Ćurčić, MA, Military Academy, Pavla Jurišića Šturma 33, tel. 065/4009049, curciemihailo@gmail.com.

Most financial institutions in its core business necessitated profit, which is not true for the budget. The budget therefore occupies an important place in preserving and developing activities that are of importance for the country.

Taking into account the characteristics of the budget as well as financial institutions and agricultural industries can be linked to development of agriculture from dependence on financial allocations from the budget of the Republic of Serbia.

Financing of Agriculture is home to the adoption of the Programme of Monetary Reconstruction in 1994, was entirely dependent on the state. The then financial support referred to under beneficiranim lending conditions, a source of funding was the primary issue of the National Bank.

At that time, loans from commercial banks that have been placed for the development of agriculture, which are financed from its own sources have also been under state control. Due to agricultural lending, in this period, the funds were administratively directed.

Since the agricultural sector is financed through several sources of funding, such as the financing of the real sector, commercial bank loans and financial leasing from the budget of the Republic of Serbia, the paper will be just represented as agricultural finance, from the budget of the Republic of Serbia.

The budget as a financial institution

Long-term growth in public expenditure caused by the expansion of the public sector in all countries with market economies. The growth of government activity increases as increasing the level of the budget and increase state intervention in all spheres of economic activity. The causes of such growth in the public sector and public expenditure, primarily located in the economic nature of state intervention, demographic and technical factors. The close relationship between the growth in public expenditure and the budget, it can be problematic when you take into account the expansion of expenditure on the one hand, and economic crisis, recession, unemployment, social transfers and other forms, on the other hand.

Public expenditure will not only increase due to the growth in demand for public services, but also due to the changed concept of the factors sociological. Meeting the needs of the individual is performed on the basis of equal need, though, the share of individual categories in the use of the budget is unbalanced, since this participation is often associated with material resources, purchasing power, the location of the user, ie, the capacity of the budget.

The political-economic models enable analysis of the interdependence of politics and economics with the center of executive power as the holder of economic and political power. Executive power is trying to maximize their own benefit taking into account their own re-election and benefits voters. This behavior can be described as relations functions of government that depends on the variables: unemployment, inflation, income growth, and the use of economic policy instruments, including budget expenditures. In this regard, the financing of agriculture as the primary economic activity in each country, occupies an important place in the route that leads to the rating of the executive branch.

The main instrument of financing public expenditure in all modern countries the budget. Budget is a basic, but in some cases the only instrument of collection of public revenues and financing public expenditures in the modern state. (J. E. Stiglitz, 2004)

As a financial institution, with all the necessary elements and with respect to the prescribed procedure, the budget appeared only in the 15th century in Europe and in some cities, and in the 17th century in certain countries (Radičević M., Raicevic B., 2011) The existence of the budget was the result of the operation of commodity-money relations in the economy.

The budget is a specific and complex document, which is a unique way, uses elements of many other laws. Whether the public revenue or public expenditure, as instruments for the budget, it has many functions. The functions of the budget are related to the objectives that the state wants and plans to achieve the one-year operation budget (Burda M., Viploš C., 2012).

Apart from a few basic functions of budget, it's necessary to mention the economic function of the budget as the most important to us in terms of this study. The economic function of the budget stems from the instruments that the state uses to achieve the objectives through policy

expenditure and revenue, since it directly affects the distribution of gross domestic product. Total public spending across the budget linked to Economics, policy and objectives to be achieved in distribution and redistribution of social product.

Part of the economic policy, which of eggs through the income and expenditure regulate the exercise of certain goals, seen as fiscal policy. Thanks to the theory of public choice resulting in USA sixties, modern economic analysis and theory of fiscal policy is getting very important socio-political and social role.

A key contribution to the development of the study of fiscal policy gave John Miner Keynes, so that the budget as a financial institution that is placed in the seat of fiscal policy gains importance (Đorđević D., Ignjatijević S., 2013).

In today's economy where more and more expressed antagonistic interests of different social groups, the economic policy is not easy to implement certain stabilization measures, despite the fact that, in terms of information and communication technologies, facilitated access to information. In this regard, the principles of public choice theory have become particularly relevant for State intervention in basic economic activities of importance for the state, what is safe and agriculture.

Agriculture as an economic activity

Agriculture and agricultural policy have an important role both at national and international levels. This is primarily supporting the fact that the period of growing European Community into the European Union, demanded the establishment of a common agricultural policy, which defines the goals of stimulating growth in production of agricultural products (Cvijanovic D., Simonovic Z., Mihailović B., 2011).

As one of the economic activities, especially after a long period of transition and the collapse of the industry in this period, agricultural activity is the main element of the healing potential of the domestic economy. In all countries with developed markets, agricultural industry has a privileged position compared to other industries, regardless of whether it is viewed through a primary or multifunctional production. As an example of how countries are part of the European Union, which is based on the incentive fund in the form of grants, as well as agriculture,

which the United States is based on the favorable "farming" loans, loans with very low interest rates.

As a sector of the economy, agriculture has come a long way of development from the primitive to the modern mode of production, modern stage in developed countries. During a very long historical period, the development of this activity was extremely slow, and if in that time constituted the basic agricultural industry in which created the largest part of the product until the Industrial Revolution. Of course, the progress of agriculture caused by the natural and cheerful or even socio-economic factors. As confirmation of this attitude is taken of changes attitude towards agriculture with the rapid development of the industry (Devetaković S., 2012).

In Serbia, according to the census from 2012. In Serbia has a total of 631,552 households where family farms predominate and constitute 99.5% of the total number of farms in Serbia, and only 0.5% households are legal per sons and entrepreneurs (RZS, 2012). Also, rural areas in Serbia is considered to be 85% of the territory, which is inhabited by 55% of the population. Based on these data we can see that it is in Serbia represented extremely primary, ie. agriculture in the narrow sense that this is a key activity of domestic producers.

Of the total number of farms in the Republic of Serbia, 47% use only 2 hectare of agricultural land, which represents a very small involvement of agricultural land in order to achieve sustainability. The reason why is not sustainable in such a way to deal with agriculture, the inability to develop competitive production and inability to reduce operating costs (SBS, 2012). The average size of farms in the European Union is 20 hectares, which means that with high productivity can be competitive in the market, but can also reduce operating costs.

Specifics of agricultural production are: high dependence on natural conditions (soil, terrain, the configuration of the soil, air, etc.), Resulting in larger or smaller fluctuations in production, higher business risks, which creates certain organizational, technological and socio-economic problems; Basically agriculture are organic production whose products are, as a rule, the living world which is why the procedures, organization and economy adjusted to biological conditions and characteristics of plants and animals, and this allows it to be from the initial live material, give much greater weight agricultural products.

In addition, during the process of production usually does not coincide with the nature of human work, but in the production combines several different products whose production time and working time are not the same, thus implementing a specific division of work and complement each other in this field (Devetaković S., 2012).

Agriculture has biological specificity, which is more demanding in terms of finance in comparison to other economic activities. The most important factors are seasonal and organic production as well as the high risks of the production cycle. The big problem is the inability of farmers specialization of production, low capacity utilization and slow capital. This means that these specifics require that in agriculture there is a need to engage in a short time significant funds that remain long attached, and all that does not support the producers. Due to such specificities, as well as the low profitability of agriculture, the necessary additional sources of financing.

Another major problem is the low productivity, which requires higher prices of products which thus become less competitive in the market.

A very important thing to note when talking about agriculture as an economic activity is the production of raspberries in Serbia last decade has the leading position in the export of agricultural products. Serbia is the world's largest exporter of frozen raspberry in the world. This is data that is optimistic to potential producers but also a turning point in their decision whether to opt for the agricultural product.

With the advent of more collection points raspberries, appeared in the competition that is not based on a monopolistic pricing system, but the free market dictates the pricing of products but also a great demand for this product. This satisfaction of participants in the production and marketing of goods partly precedes the help of the state and the agricultural budget in the form of giving subsidies. We consider it to state, in order to meet the revenue side of the state budget should not only subsidies but favorable loans with low interest rates, without a currency clause and with longer grace period, meet the farmers. In that farmers would in time be able to obtain high-quality machinery, equipment and working capital funds, loans would come at a charge after a few years of making a profit, and revenue side of the budget would be met.

When we consider the problems listed agricultural producers and Serbia as a country which is on the path of European integration, we can conclude that the key solution to revive agriculture in the Republic of Serbia increased funding of the agricultural budget and additional programs lending by development banks.

Agriculture and Agro-budget financing

Financing agriculture in a market economy can not be realized without the realization of the privatization process in the economies of the countries in transition. All engagements of foreign capital I “greenfield” investment, through the purchase of domestic companies, are closely associated with the privatization process in these countries. In addition to the great variety of forms of privatization, which are present in the transition economies, the conditions which the Government of a country set to achieve sales through privatization tend to reflect her concern over the question of what impact this agreement will have on the privatization of the national labor market, economic development, environmental protection, as well as agricultural development.

The aim is certainly providing further engagement not only funds from the budget that are subject to sales revenues (privatization), but further involvement of foreign partners in terms of employment, additional investment and further development of the subject of privatization (Ignjatijević S., 2015).

Agricultural policy is one part of the economic policy of a national economy or wider integration process which is focused on directing the development of agriculture and with her directly associated activities on various grounds.

Agricultural policy consists of several interconnected elements - the objective of agrarian political activities, resources, measures and methods of operation, and the bearers of agrarian policy. All of them, of course, act in a certain space and time, as a result of their joint achieved by changes in agriculture or an activity directly related (Devetaković S., 2012).

Agricultural budget as a source of funding for agriculture has become part of the state budget in 1996. This is a consolidated form of state support to agriculture which implements agricultural production through subsidies. The Government of the Republic of Serbia, at the proposal Ministry of

agriculture and environmental protection, in accordance with the Law on Budget of each year determines the amount agragnog budget which, after approval in the form of subsidies available to the agriculture. Analysis of the data in the reporting period, we can conclude that the share of the agricultural budget in the total budget of the Republic of Serbia amounts to an average of only 4.1% (Ministry of Finance, 2016).

For the purpose of agricultural development in the Republic of Serbia, it is necessary that in the future increase the participation of agar in the total budget of the Republic. An example of Slovenia, as a country that has carried out the most successful transition, which is in the transition period up to 2010, managed to increase allocations for the agricultural budget by about 7 times.

Also, because ravnemernog development and rural areas, it is necessary to increase the allocations from the agricultural budget for the encouragement and development of rural areas. For example, a data and work that should be a leading indicator, and our country is that the agricultural budget of the European Union, about 20% is allocated to rural development (Radovic, 2011).

In this connection, mention another way of agriculture financing from the budget of the Republic of Serbia, and that is lending to agriculture. Ministry of Agriculture in 2010 began the system of agricultural credit support in setting participants in production. This method of lending is reflected in the inclusion and through commercial banks. Typical for these loans is low interest rates, and the funds are to come from commercial banks agragnog budget. The right to use these loans have only registered farms. The main objective of this lending is to agricultural entities provide easier access to the credit market. And from this we can see that the only real way and financing of agriculture is financing from the state budget. Also, lending to the agricultural and rural development is implemented through specialized state institutions. These loans are granted under favorable conditions, and implemented them Fund for Development of the Republic of Serbia and aim to encourage agricultural production in rural areas.

In the transition period commercial bank loans for agriculture were rather unfavorable with high interest rates, were in euros, with the high costs of credit insurance, the lack of a grace period of repayment and a lot of disadvantages. With the arrival of a large number of commercial banks in

our region, this negative trend has changed and they are now much more favorable conditions for farmers. Lower interest rates and short-term loans in dinars gave a big boost agricultural producer for taking the loan. Despite this disadvantage of agriculture lending of commercial banks is that they are still long-term loans in euros (Veselinovic B., Drobnjaković M., 2014).

It should be, agricultural entities in Serbia, offer adequate agricultural loans, without currency clause custom seasonal nature in agricultural production, as well as the spending power of farmers.

Also flood, should be offered to commercial banks, as well as other legal entities and investors the opportunity to invest in agriculture in Serbia. The investment, which is financed from the reservoir, a material basis for enlargement reproduction since they increase the fixed and current cash assets in activities in which it invests. Due to this, the growth of agricultural production is a function of investment in this industry and their functions (Devetaković S., 2012).

Based on the above, one possible solution is the creation of a special Agricultural Bank, which would operate on the model of business-banking at the territory of Serbia, but with many advantages in favor of agricultural enterprises and potential users. Agricultural Bank would be financed from the state budget or the agricultural budget, with preferential interest rates, without a currency clause, the longer the grace period, which would increase the interest in this type of loan, which would be accessible to a greater number of agricultural subjects (Radovic G., 2011).

One brand new model of financing that is extremely present in the agricultural sector is financial leasing. This system of financing is regulated by the Law on financial leasing in 2013 and in the previous period had a very important role in financing investment in agriculture, especially in the procurement of agricultural mechanization and equipment. The cost of leasing repayment rather oprećuju creditworthiness and the costs of bank guarantees for agricultural entities. Financing through leasing to farmers that purchased machinery and equipment can be immediately used in the production process, and that odplata realized from its profits.

An alternative way finansirnja Agriculture has candidate status for membership in the European Union. Serbia became a requirement to

apply the pre-accession aid program by the European Union. The aim of this financial support is to prepare future Member States for implementation rate of agriculture make joint policy with the aim of sustainable development of agriculture and rural development.

Methods

In this paper, we use the correlation to determine the relationship status and structure of expenditure financing from the budget and the individual factors of agriculture in the Republic of Serbia. In order to evaluate economic factors and ways of financing the budget work of agriculture on the one hand and elements of repairing agricultural production will use a variety of analytical indicators. One of the main variables of GDP and the budget of the Republic of Serbia, which will be the size considered in this study.

In addition to used and relations between budget appropriations representing shares on the expenditure side of the budget designated for the purpose of financing agricultural expenditure, which is also an indicator of the share of expenditure in total government spending as an integral part of the GDP (Žižić M., Lovric M., Pavličić D., 2007).

As a measure of the state of agricultural subsidies indicators are used for agriculture, the source of agricultural and food products. These indicators show the level of subsidization of agriculture in relation to it from the budget (Mladenovic Z., Nojković A., 2012).

The paper used data from the National Bank of Serbia, the Ministry of Agriculture and Environment of the Republic of Serbia, the Institute for Statistics of the Republic of Serbia, the period from 2010 to 2014. For the study we used a model $GDP = C + I + G + X - M$, the expenditure method of determining GDP, in which C denotes private consumption, G public consumption, I investment, X exports and M imports.

During the research we applied the Pearson correlation coefficient model $r_{xy} = C_{xy} / (SD_x \cdot SD_y)$ where C_{xy} denotes covariance and $SD_x \cdot SD_y$, product standard deviations $h_i y_i$.

In order to perform the valuation in the coming period in line with economic developments, we used the method of linear time trend $y = b_0 + b_1X$, wherein Y is a linear function b_0 (average) and b_1 (mean absolute

increase) represent estimates of parameters, and x represents time information. For the calculation of estimates of trend parameters used method of least squares.

Results

In the study, starting from the data we collected and the methods we use we performed statistical data preparation for the possibility of their processing.

Table 1. *Financial indicators in the Republic of Serbia mill. RSD*

Year	Budget	Agriculture allocations	Subsidies from the budget for Agriculture	Exports of agricultural and food products	The total balance of foreign trade of agriculture	The share of the agricultural budget in the total budget (%)
1	2	3	4	5	6	7
2010.	714.823,84	31.577,90	18.000,00	246.510,00	132.550,00	3,8
2011.	804.947,31	33.676,00	20.000,00	297.000,00	143.000,00	4,1
2012.	824.481,00	40.867,70	19.945,00	298.980,00	136.950,00	4,0
2013.	965.700,00	44.699,50	41.058,00	308.000,00	135.960,00	4,3
2014.	929.902,00	45.427,20	34.952,00	337.480,00	157.190,00	4,1

Source: *National Bank of Serbia, Ministry of Finance*

We performed an analysis of the budget of the Republic of Serbia (h) and subsidies from the budget of the Republic of Serbia for agriculture. By applying PEARSON'S method of correlation we found that the correlation value is, $r_{xy} = 0.84$ which is classified as highly positive correlation.

If from the table above as a phenomenon (h) subsidies from the budget of the Republic of Serbia for the projected year (2010-2014), and as a phenomenon (the) Exports of agricultural and food products in the Republic of Serbia, by applying PEARSON correlation method, we found that the value of the correlation coefficient is $r_{xy} = 0.75$ which is classified as highly positive correlation.

By applying PEARSON correlation method, we found that the value of the correlation coefficient, analysis (h) *izdvajnje* from the budget for agriculture of the Republic of Serbia, and (u) the total balance of foreign

trade and agricultural production prerambene, $r_{xy} = 0.89$ which means that the correlation coefficient in a very positive correlation.

Chart 1. Budget allocations for agriculture of the Republic of Serbia



Source: From the results obtained in the survey authors

By calculating the time linarnog trend we have come to a linear trend model $y = 28035.37 + 3872,21x$, where the mean absolute increase in the present period of 3872.21 million. Calculating the value of the trend in 2020, we came to the result of 62,885.26 million.

Conclusion

Financing is a major issue for the development of agriculture. Difficult period of transition to domestic agriculture, as well as other economic activities, has left a deep mark.

Therefore, we have a pretty non-competitive agriculture, with outdated equipment, which can not achieve a sufficient degree of productivity,

which is itself the product price higher, with which our farmers are not competitive in the market.

This is especially true in rural areas and small producers, or producers in the narrow sense, which make up the majority. Based on the method of correlation we found that the growth of the budget of the Republic of Serbia is growing and extraction for agriculture, but also for the agricultural budget, and growth and subsidies for agriculture.

This is a good sign for agriculture as a whole, or to reach the desired results it is necessary:

- To set up an effective mechanism to control implementation subvencinisanih loans and funds from the budget, through agricultural projects aimed at rural development,
- Prioritize the funding of certain elements of agriculture, and that the comparative advantages of Serbia in relation to neighboring countries,
- Solve the status of agricultural land in private ownership as an economic resource, which is the family inheritance is divided into smaller parcels, and therefore used inefficiently.

And in the end we can conclude that the recovery and progress of agriculture needs a dominant role of the state and the state budget as a financial institution. Also, the dominant role of the state caused by the underdevelopment of financial markets and financial institutions that would enable greater activation of market mechanisms and financing of agriculture.

Literature

1. Burda Michael, Viploš Charles (2012): *Macroeconomics: European textbook* translation 5th Edition, Faculty of Economics in Belgrade, Center for Publishing, pp. 49-515.
2. Cvijanović D., Simonovic Z., Mihailovic B. (2011): Focal points and objectives of the recent reform of agricultural and regional policy of the European Union, *Agricultural Economics*, Vol. 58, No. 3, pp. 359-370.
3. Devetaković Stevan (2012): *Development opportunities agroindustrial Serbia*, *Economics vistas*, University of Belgrade, Faculty of Economics, Vol 17, No 3, p. 531-545.

4. Ignjatijević Svetlana (2011): *Economic analysis of the significance of foreign direct investment*, auditor, Vol 1, No 11, pp. 4-15.
5. Mladenovic Zorica, Nojković Aleksandra (2012): *Inflation persistence in central and southeastern Europe: Evidence from univariate time series and structural approaches*, Paneconomicus, Scientific Paper, Vol 59, No 2, pp. 235-266.
6. Radičić M., Raičević B. (2011): *Public Finance: Theory and Practice*, Data status, Belgrade.
7. Radovic G., Pejanović R. (2011): *Agricultural policy in the Republic of Serbia in the period of transition*, Economics: Theory and Practice, University of Novi Sad, Faculty of Economics & Engineering Management, Vol 4, No 1, pp. 29-38.
8. Stiglitz, E. J. (2004): *Public Economics*, Faculty of Economics in Belgrade, Publishing Center.
9. The Ministry of Finance/Ministry regulations finansija
<http://www.mfin.gov.rs/pages/issue.php?sf=6&id=1578> (09.23.2016).
10. The National Bank of Serbia, the gross domestic product of the Republic of Serbia
http://www.nbs.rs/export/sites/default/internet/latinica/80/realni_sektor/SBRS01.xls (09.23.2016.).
11. The Republic Institute for Statistics, Statistical Yearbook of the Republic of Slovenia in 2012.
12. Veselinovic Branislav, Drobnjaković Maja (2014): Qualitative and quantitative analysis of micro and macro aspects of agricultural finance, Agricultural Economics, University of economic akademije in Novi Sad, Faculty of Economics & Engineering Management, Vol 61, No 3, pp. 771-787.
13. Žižić Mileva, Lovrić Miodrag, Pavličić Dubravka (2007): *Methods of statistical analysis*, Faculty of Economics in Belgrade, Center for Publishing, pp. 1-450.

THE INFLUENCE OF DEMOGRAPHIC CHARACTERISTICS OF CONSUMERS ON HONEY BUYING BEHAVIOUR

Maja Ćirić¹, Svetlana Ignjatijević²

Abstract

The purpose of this paper is to determine whether and to what extent the demographic characteristics of consumers in Vojvodina affect the quantity of honey bought, frequency of purchases, the price consumers are willing to pay and the usual place of purchase. The findings on whether there are differences in the behavior of consumers in purchasing honey in Vojvodina, depending on gender, age, education, household type and income, are a very important indicator for all honey producers which place or intend to place their honey on the market of Vojvodina. Based on such findings, honey producers are able to identify the demographic profiles of their current and prospective consumers, and accordingly create their marketing strategy. The preparation of this paper involved using the survey method on a sample of 500 respondents in the territory of Vojvodina. The conclusion sums up the impact of each examined demographic characteristic of consumers on the differences in their behavior when purchasing honey.

Keywords: *demographic characteristics of consumers, purchasing habits, honey consumption, marketing strategy, product placement*

Introduction

The average honey production in Serbia amounts to 4,173 t of which 11.24% has been produced in Vojvodina. The yield of honey production amounts to an average of 12.67 kg per hive, while in Vojvodina it amounts to 11.45 kg. Beekeeping is now popular in Serbia and Vojvodina and people deal with it professionally and some of them as a hobby

¹ Maja Ćirić, Ph.D., Associate professor, Faculty of Economics and Engineering Management in Novi Sad, Cvećarska 2, Novi Sad, Phone: +381 21 400 484, E-mail: majacic79@yahoo.com.

² Svetlana Ignjatijević, Ph.D., Associate professor, Faculty of Economics and Engineering Management in Novi Sad, Cvećarska, 2, Novi Sad E-mail: svetlana.ignjatijevic@gmail.com.

(Ignjatijević et al., 2015). Grubić (2008) points out that "beekeeping in Vojvodina has the potential for success, because this plain is diverse with flora - bee plants that grow in this fertile plain." According to experts, beekeeping production in Vojvodina (using the latest scientific achievements and accessories) could increase five to ten times in the next ten years. However, the problems that honey producers in Serbia and Vojvodina encounter in their efforts to increase the production and placement of their products both in the domestic and especially the foreign market are numerous. One of the key problems definitely lies in the non-possession of adequate knowledge in the field of marketing, lack of understanding of the needs, desires, motives and habits of consumers and therefore the inability to create a proper marketing strategy and marketing program, which would allow an increase in market share, both in the domestic and international markets (Ćirić et al., 2015). Therefore, studying of consumer behavior while purchasing honey and factors that affect consumer behavior is crucial in decision making of producers regarding any type of marketing activity.

Consumer behavior is defined as the behavior that consumers project in searching for, using, purchasing, evaluating, and disposing of products and services that they assume will satisfy their needs (Pelau, 2011). Researching consumer behavior studies the manners in which consumers actually use the products and services they buy, how many different brands they use, how often and where they make purchases and, above all, why they buy and use them. The structure of consumer behavior includes what people buy, why, how and where, when and how often they buy products and services (Maričić, 2008). The factors that affect consumer behavior can be divided into two major groups: external and internal factors. External factors include demographic, economic, geographical and sociological factors. Internal factors consist of the characteristics of personality, its features and mental conditions. Although they manifest in an individual manner, they are strongly influenced by external factors and affect the formation of attitudes, opinions, teachings and motives of consumers (Novaković Rajčić, 2005). The analysis of factors affecting consumer behavior is a very complex process, but it is of great significance to every market-oriented company, given that it provides them with the necessary information that is essential for defining target markets, creating appropriate marketing strategies and programs and thus represents a precondition for long-term market positioning. In order to explain consumer behavior in purchasing honey, it is of utter importance to commence from the analysis of their demographic

characteristics. Namely, first of all, it is very important to perform an analysis whether there are differences in consumer behavior with regard to gender, age, education, household members and income, which are the most important demographic characteristics. Knowledge of demographic characteristics of consumers, who are the target market segment of companies, represents the starting point for the adoption of all marketing decisions. It is absolutely impossible to create a suitable marketing strategy or make decisions about the marketing program if we are not familiar with the demographic characteristics of the target group of consumers we are addressing. It is important to note that the differences in certain demographic characteristics of consumers do not always reflect their purchasing behavior in the same manner, since their behavior is also defined by the type and characteristics of the product itself. In case of certain products, there are differences in consumption depending on gender, while with other products there are differences depending on age and the like. It is therefore of utter significance to companies, in this case the producers of honey in Vojvodina and other producers interested in the placement of honey in the market of Vojvodina, to find out whether there are differences in the behavior of consumers in purchasing honey depending on their demographic characteristics, which is actually the main purpose of this research.

Importance of demographic factors in understanding consumer behavior

Demographic data on consumers are objective and quantitatively expressed characteristics of population. They are easily identified, collected, measured and analyzed. Demographic changes are of particular importance in marketing, due to the fact that the number, age structure and mobility of the population determine the actual and potential demand in the market and create the demographic profile of consumers. The demographic profile of consumers consists of objective and measurable characteristics of people. These are the factors that have a long lasting impact on marketing activities and define the micro and macro environment of companies (Maričić, 2008, p.169). Demographic characteristics are innate physical, social, economic and geographical features that make a person and describe the position of such person in his or her environment (Solomon, 1995). According to (Schiffman and Kanuk, 2004) demographic characteristics such as age, gender, marital status, income, occupation and education are most often used as a basis for market segmentation. Demographic data make it possible to locate the

target market. After researching various demographic factors, an organization can create the demographic profile of consumers, i.e. the demographic structure of a consumer group. Based on the consumer profile, the organization can determine both attractive and declining market opportunities.

In order to explain in more detail why the demographic characteristics are of such importance for understanding the behavior of consumers of honey and all marketing activities that honey producers should plan, we have observed individually each demographic characteristic that is relevant to our research, as well as the results of similar researches conducted in Hungary, Romania and Poland.

Gender structure is very important for planning marketing activities since genders differ from one another when it comes to purchasing products and services that are specifically intended for them, although many product categories are used equally (Milisavljević, 2005). Schiffman and Kanuk, (2004) point out that today gender roles are losing their clear boundaries and that gender is no longer an accurate way of differentiating consumers in certain product categories. Therefore, for producers of certain products it is extremely important to determine whether there are differences among genders in terms of consumption of their products, in order to obtain clear guidelines in creating their marketing programs. The age of an individual affects the interests, tastes, ability to purchase, political preferences and behavior in terms of investments. Consumers in various age groups have very different needs and desires, as well as different financial abilities. Age is a factor which significantly affects the differences in the process of purchasing products and services, i.e. behavior in consumption. Each age group represents a potential market for specific products and services and ranges in size (Maričić et al, 2008). Therefore, when defining the demographic profile of potential or existing consumers of honey, it is crucial to identify the behavioral differences depending on age. The level of education of consumers directly or indirectly affects their behavior in a specific marketing situation. Desires, habits and interests of consumers grow and change together with the rise of education level (Novaković-Rajčić, 2005). Marketing experts are particularly interested in the number and type of households that buy and/or possess certain products. They are also interested in determining the demographic and media profiles of decision makers in order to develop appropriate marketing strategies. Family structure has a huge impact on consumers' spending priorities. In developed countries, all

major changes have occurred in family structure. The number of families with a reduced number of members increases, together with family age and share of employed women. All this reflects on the companies' marketing efforts (Živković, 2011). The number of single-person households and those without family will hold an increasing share of the market in the future (Kotler et al. 2007). Income has always been a very important economic and demographic characteristic for differentiating market segments. Producers of products and services usually segment their markets based on income, since they observe it as the key indicator of the ability to purchase a product or service. In defining the demographic profiles, income is usually combined with education and occupation given that they are closely related (Schiffman and Kanuk, 2004). According to (Roman et al., 2013.) the main determinants of the number and structure of purchased goods are consumer preferences and consumer budget constraints.

A research of purchasing habits of honey consumers was conducted in eastern Hungary on a sample of 902 respondents. The respondents have been sorted by gender, age, qualifications and income. It was found that the most important criteria in all consumer groups during honey purchases were quality, price, type of honey and quality of packaging. It was also determined that elderly people usually bear in mind the price, producer's name and pack size (Vanyi et al., 2011). Upon conduct of a recent research conducted in northwestern Romania, the authors Pocol and Bolboacă (2013) came up with the following findings. Education, occupation and age were factors that significantly influence consumer opinions from the North-West of Romania regarding the real and symbolic value of honey. They determined that, for the elderly, people with little education and the unemployed price may be considered a decisive factor in the decision to purchase honey. Apart from that, they also concluded that there was a significant difference in the quantity of honey purchased, as those with higher education purchased larger quantities of honey in comparison to others. In Poland, honey is mostly consumed by the elderly and children (Roman et al, 2013). In the same research, economic factors such as the level of the net income per person in the household and the price of the product had a significant, but not mandatory influence on the purchasing decisions of honey consumers. The above researches show the variety of impacts of demographic characteristics of consumers on purchasing habits in the consumption of honey in different countries, and therefore it is purposeful to determine their impact on the purchasing habits of consumers in Vojvodina.

Research method

The subject of this research is to determine the impact of demographic characteristics on the differences in behavior of honey consumers in Vojvodina. This paper analyzes the major demographic characteristics of a randomly selected sample of consumers in Vojvodina, which are then connected to the quantity of honey purchased by them, frequency of purchase, the price of honey they are willing to pay and the usual place of purchase.

The aim of this paper is to determine the factors that have the strongest influence on the differences in consumer behavior in purchasing honey, since such data are essential for creating marketing strategies and programs of all honey producers in Vojvodina, as well as all other producers who want to place their honey on the market of Vojvodina. In addition, the above data are important for planning short-term and long-term demand for honey in the market of Vojvodina, which is again significant from the aspect of investments of producers in improving the production and quality of the product itself, i.e. honey.

In researching consumer behavior we applied the quantitative research method, in order to carry out statistical analysis and generalize the obtained results onto broader population. We applied the survey method, and the instrument used for conducting the survey was a questionnaire which was not standardized but created for the purpose of this research. We opted for data collection through phone calls and via e-mail.

The research sample consisted of 500 randomly selected respondents. We used the method of random selection for selecting a representative sample. The data were analyzed using SPSS for Windows 20. The following methods were used: descriptive statistics - frequencies and percentages and Pearson's chi-squared test for independent samples.

Research results and discussion

Starting from literature review, in this research we selected gender, age structure, education, household type and income as the most important demographic characteristics of consumers (independent variables). Later in the research, we analyzed how they reflected in consumer behavior during purchases by studying the frequency of purchases of honey, the

size of honey pack, prices paid by consumers and the usual place of purchasing honey (dependent variables).

Based on the data presented in Table 1, we notice that the highest percentage of both men and women purchase honey once every three months in pack size of 1 kg, at a price of 5 to 10 Euros for 1 kg of honey, and that they purchase honey directly from producers. The difference between genders was verified using the Chi-square test for independent samples, where the set of dependent variables consisted of answers to questions about purchasing behavior, while the grouping variable was the respondents' gender. Given that the Chi-square statistics for gender and each dependent variable with $df=2$ has a $p>0.05$ we can conclude that there is no statistical significance of any of the dependent variables in relation to gender. This means that gender as a demographic factor does not significantly affect the behavior of consumers during honey purchases. That is to say that, when defining marketing strategies, both men and women are classified into the same target segment and it is not necessary to create a special marketing program for men and another for women, given that there are no differences in their behavior. This finding is in line with the view of Schiffman and Kanuk, (2004) that today gender is no longer an accurate way of differentiating consumers in certain product categories.

The data presented in Table 2 indicate that the highest percentage of consumers aged under 20, between 21 and 30, 31 and 40, 51 and 60 and over 60 years of age purchase honey once every three months, while the highest percentage of consumers aged between 41 and 50 purchase honey once a month. According to the descriptive statistics indicators, the age segment between 41 and 50 years of age represents the segment of consumers who purchase honey most often; however, in order to determine whether there are differences statistically significant to the entire observed sample when it comes to the connection between age and frequency of purchase, we used the Chi-square test and confirmed that there are no statistically significant differences in the frequency of purchase in relation to age, given that $\chi^2 = 14.316^a$ with $df=12$ and $p=0.281$. When we compare all of the above age categories and the size of pack, we realize that the highest percentage of all age categories except the group under the age of 20 purchase 1 kg of honey. People younger than 20 mostly purchase 500g of honey. However, when we analyze the percentages of honey purchases, we observe that 80.8% of persons older than 60 purchases 1 kg of honey while only 42.9% of consumers aged

between 21 and 30 purchases 1 kg packs. Therefore, we realize that younger categories of consumers have a higher tendency towards purchasing smaller 500g packs, while the older categories of consumer prefer larger 1kg packs. This is also in line with a research conducted in Poland (Roman et al, 2013) according to which older people consume the largest quantities of honey.

Descriptive statistics indicate that there are differences in the relationship between the size of pack purchased and age, as confirmed by the Chi-square test ($\chi^2 = 39.15^a$, withdf=12 and $p=0.000$). By comparing the prices that consumers pay for 1kg of honey and age, we can conclude that the highest percentage of all age categories of up to 50 pay between 5 and 10 Euros for 1 kg of honey, while 50% of consumers aged between 51 and 60 pay less than 5 Euros for honey, 50% of them pay between 5 and 10 Euros, while consumers older than 60 years of age mostly pay less than 5 Euros for 1 kg of honey.

Based on descriptive statistics, we notice that the elderly categories of population are those who pay a lower price for 1 kg of honey in a slightly higher percentage, which is in accordance with their ability to pay. This is in line with the research of (Vanyi et al., 2011) according to which elderly people mostly bear in mind the price and size of packs. The above also partly coincides with the research conducted by PocolandBolboacă, 2013) according to which elderly people consider prices to be the key factor in making a decision to purchase honey.

However, the Chi-square test showed that the observed differences are not statistically significant. There are no significant statistical differences between the prices that consumers pay for 1 kg of honey and age ($\chi^2 = 20.129^a$, withdf=12 and $p=0.65$). However, although there are no statistically significant differences, in creating marketing strategies it is nevertheless necessary to take into account the fact that the descriptive statistics showed that elderly consumers have a more pronounced tendency towards lower prices of honey in relation to others.

All age categories of consumer mostly purchase honey directly from producers, and there are no statistically significant differences in that matter ($\chi^2 = 24.665^a$, withdf = 30 and $p=0.741$).

Table 1. CROSSTABS Gender

Gender *		Femal		Male		χ^2
		Count	% within	Count	% within Gender	
How_often_d o_you_buy_h oney	At least once a month	87	28.4%	60	30.9%	$\chi^2 = .493^a$ df 2; Asymp. Sig. (2-sided)= .782
	Once in 3 months	128	41.8%	81	41.8%	
	Once in 6 months	91	29.7%	53	27.3%	
What_packag e_size_of_ho ney_do_you_ buy_honey	1kg	176	57.5%	100	51.5%	$\chi^2 = 1.781^a$ df 2; Asymp. Sig. (2-sided)= .410
	250g	38	12.4%	29	14.9%	
	500g	92	30.1%	65	33.5%	
What_price_d o_you_pay_fo r_1_kg_of_ho ney	5 euros	114	37.3%	62	32.0%	$\chi^2 = 1.974^a$ df 2; Asymp. Sig. (2-sided)= .373
	5-10 euros	156	51.0%	103	53.1%	
	More than 10 euros	36	11.8%	29	14.9%	
Where_do_yo u_most_ofte n_consume_ho ney	Directly from manufacturer	168	54.9%	116	59.8%	$\chi^2 = 2.889^a$ df 5; Asymp. Sig. (2- sided)=.717
	Grocery shop	26	8.5%	19	9.8%	
	Market/exhibition	80	26.1%	40	20.6%	
	Monstery	6	2.0%	2	1.0%	
	Organic product shops	11	3.6%	7	3.6%	
	Supermarket (GOD)	15	4.9%	10	5.2%	

Source: Created by the authors based on authors' survey within the project „Lime Trees & Honey Bees for Sustainable Development of the Danube Microregion” No: 6526-00/2011/Grant 64, the project is funded by the European Union and the Austrian Development Agency.

Table 3 shows the data pointing to the fact that consumers at almost all education levels mostly purchase honey once every three months, except for consumers with college education who purchase honey once a month in a slightly higher percentage.

The Chi-square test confirmed that there were no statistically significant differences between the frequency of purchases of honey and level of education ($\chi^2 = 14.278^a$, withdf= 8 and p=.075). When observing the relationship between the size of pack to be purchased and the level of education, we notice that the highest percentage of consumers of all education levels, except for those with elementary school degrees, purchase 1 kg of honey. These data differ from the research conducted by Pocol and Bolboacă, 2013) in which it was found that honey consumption increases with the rise of educational level of the population.

However, it is interesting to note that not a single consumer who has an elementary school degree purchases 1 kg packs of honey, but 50% of them purchase 500g and 50% 250g packs. This can be related to the fact that people younger than 20 usually buy 500g packs, which means that young people with completed elementary school and which attend secondary school have different needs in comparison to older and more educated population.

The Chi-square test confirmed that there is a statistically significant difference in the level of education and size of purchased pack ($\chi^2=20.486^a$, withdf=8 and $p=.009$) - Table 2. Consumers of all educational levels mostly purchase honey at a price ranging between 5 and 10 Euros. The Chi-square test confirmed that there is no statistically significant difference in the level of education and the price of honey purchased ($\chi^2=8.378^a$; with df=8 and $p=.397$). Also, consumers of all educational levels mostly purchase honey directly from honey producers.

The Chi-square test confirmed that there is no statistically significant difference in the level of education and place of purchase of honey ($\chi^2=25.411^a$, with df=20, and $p=.186$) - Table 3.

The data presented in Table 4 provide us information about the fact that, in terms of percentage, households with a monthly income below 500 Euros mostly purchase honey once every six months, while households with income between 500 and 1000 Euros and over 1000 Euros mostly purchase honey once every three months.

However, the differences in percentages are minimal to be considered statistically significant, as confirmed by the Chi-square test ($\chi^2 = 12.449^a$, withdf=8 and $p=0.132$). When we observe the relationship between household income and the size of honeypack we can conclude that households with income above 1000 Euros mostly purchase 1kg packs, followed by households with income between 500 and 1000 Euros, while households with income below 500 Euros purchase 1kg packs least often. Also, one may observe that households with income above 1000 Euros least often purchase 250g packs, followed by households with income between 50 and 1000 Euros, while 250g packs are mostly purchased by households with income below 500 Euros.

Table 2. CROSSTABS Age

	Age												χ^2		
	<20		> 60		20-30		31-40		41-50		51-60			No answer	
	Count	% within Age	Count	% within Age	Count	% within Age	Count	% within Age	Count	% within Age	Count	% within Age		Count	% within Age
How often do you buy honey	3	33.3%	10	38.5%	52	29.7%	41	24.7%	33	39.3%	8	20.5%	0	0.0%	$\chi^2 = 14.316$; df12; Asymp.Sig. (2-sided) = .281
At least once a month															
Once in 3 months	4	44.4%	13	50.0%	74	42.3%	69	41.6%	28	33.3%	20	51.3%	1	100.0%	
Once in 6 months	2	22.2%	3	11.5%	49	28.0%	56	33.7%	23	27.4%	11	28.2%	0	0.0%	
What package size of honey do you buy honey	3	33.3%	21	80.8%	75	42.9%	90	54.2%	57	67.9%	29	74.4%	1	100.0%	$\chi^2 = 39.157$; df12; Asymp.Sig. (2-sided) = .000
1kg															
250g	2	22.2%	2	7.7%	35	20.0%	16	9.6%	6	7.1%	6	15.4%	0	0.0%	
500g	4	44.4%	3	11.5%	65	37.1%	60	36.1%	21	25.0%	4	10.3%	0	0.0%	
5 euros	2	22.2%	13	50.0%	50	28.6%	55	33.1%	36	42.9%	19	48.7%	1	100.0%	
5-10 euros	6	66.7%	13	50.0%	94	53.7%	88	53.0%	42	50.0%	16	41.0%	0	0.0%	$\chi^2 = 20.129$; df12; Asymp.Sig. (2-sided) = .065
More than 10 euros	1	11.1%	0	0.0%	31	17.7%	23	13.9%	6	7.1%	4	10.3%	0	0.0%	
Directly from manufacturer	5	55.6%	19	73.1%	96	54.9%	93	56.0%	47	56.0%	23	59.0%	1	100.0%	
Grocery shop	1	11.1%	0	0.0%	18	10.3%	15	9.0%	10	11.9%	1	2.6%	0	0.0%	$\chi^2 = 24.665$ df=30;
Market/exhibition	2	22.2%	6	23.1%	43	24.6%	36	21.7%	23	27.4%	10	25.6%	0	0.0%	Asymp.Sig. (2-sided) = .741
Monastery	0	0.0%	0	0.0%	1	.6%	4	2.4%	1	1.2%	2	5.1%	0	0.0%	
Organic product shops	1	11.1%	1	3.8%	5	2.9%	10	6.0%	0	0.0%	1	2.6%	0	0.0%	
Supermarket (GOD)	0	0.0%	0	0.0%	12	6.9%	8	4.8%	3	3.6%	2	5.1%	0	0.0%	

Source: Created by the authors based on authors' survey within the project „Lime Trees & Honey Bees for Sustainable Development of the Danube Microregion” No: 6526-00/2011/Grant 64, the project is funded by the European Union and the Austrian Development Agency.

This indicates the fact that households with higher income purchase larger packs of honey, and those with lower income purchase smaller packs of honey.

The data obtained are in line with the research conducted by (Roman et al, 2013) according to which household income is an important factor that affects honey consumption.

The statistically significant difference in the relationship between household income and the size of honey pack has been confirmed by the Chi-square test ($\chi^2 = 17.736^a$, with $df=8$ and $p=0.023$).

Regardless of income level, all households mostly purchase honey with the price ranging between 5 and 10 Euros while the Chi-square test has not confirmed any statistically significant differences between the honey price and household income variables ($\chi^2 = 14.208^a$, with $df=8$ and $p=0.076$).

Also, there have been no statistically significant differences in the relationship between place of purchase and household income, all in their highest percentage, which do not differ significantly and purchase honey directly from producers ($\chi^2 = 25.788^a$, with $df=20$ and $p=0.173$) - Table 4.

Based on the data presented in Table 5, we notice that the highest percentage among all types of households purchase honey once every three months and that there are no statistically significant differences ($\chi^2 = 12.105^a$ with $df=6$ and $p=.060$).

When we observe the relationship between the size of packs to be purchased and household type, we see that households in which customers are persons, i.e. parents with children, and households with people who have both children and their own parents living together mostly purchase 1kg packs of honey, in comparison to the percentage of households where people live alone without children and parents, as well as households in which customers are children living with their parents.

Tabela 3. CROSSTABS Level of education

	Level_of_education												χ^2			
	Elementary school			Graduation			High school			Middle school				Other (MA, PhD)		
	Co unit	% within Level of education	Count	% within Level of education	Count	% within Level of education	Co unit	% within Level of education	Count	% within Level of education	Co unit	% within Level of education		Count	% within Level of education	
How_often_do_you_buy_honey	At least once a month	1	25.0%	38	25.9%	17	39.5%	44	37.6%	47	24.9%	$\chi^2=14.278^*$;df8; Asymp.Sig. (2-sided) = .075				
	Once in 3 months	1	25.0%	70	47.6%	13	30.2%	48	41.0%	77	40.7%					
	Once in 6 months	2	50.0%	39	26.5%	13	30.2%	25	21.4%	65	34.4%					
What_package_size_of_honey_do_you_buy_honey	1kg	0	0.0%	90	61.2%	23	53.5%	49	41.9%	114	60.3%	$\chi^2=20.486^*$;df8; Asymp.Sig. (2-sided) = .009				
	250g	2	50.0%	17	11.6%	4	9.3%	22	18.8%	22	11.6%					
	500g	2	50.0%	40	27.2%	16	37.2%	46	39.3%	53	28.0%					
What_price_do_you_pay_for_1_kg_of_honey	5 euros	0	0.0%	59	40.1%	14	32.6%	36	30.8%	67	35.4%	$\chi^2=8.378^*$;df8; Asymp.Sig. (2-sided) = .397				
	5-10 euros	3	75.0%	70	47.6%	23	53.5%	60	51.3%	103	54.5%					
	More than 10 euros	1	25.0%	18	12.2%	6	14.0%	21	17.9%	19	10.1%					
Where_do_you_most_often_consume_honey	Directly from manufacturer	2	50.0%	85	57.8%	21	48.8%	59	50.4%	117	61.9%	$\chi^2=25.411^*$;df20; Asymp.Sig. (2-sided) = .186				
	Grocery shop	1	25.0%	12	8.2%	4	9.3%	8	6.8%	20	10.6%					
	Market/exhibition	0	0.0%	35	23.8%	14	32.6%	36	30.8%	35	18.5%					
	Monastery	0	0.0%	2	1.4%	1	2.3%	0	0.0%	5	2.6%					
	Organic product shops	1	25.0%	6	4.1%	0	0.0%	5	4.3%	6	3.2%					
	Supermarket (GOD)	0	0.0%	7	4.8%	3	7.0%	9	7.7%	6	3.2%					

Source: Created by the authors based on authors' survey within the project „Lime Trees & Honey Bees for Sustainable Development of the Danube Microregion” No: 6526-00/2011/Grant 64, the project is funded by the European Union and the Austrian Development Agency.

Table 4. CROSSTABS Total average income of your household

	< 500 euros		> 1000 euros		501 - 1000 euros			
	Count	% within Total average income of your household	Count	% within Total average income of your household	Count	% within Total average income of your household		
How often do you buy honey	At least once a month	21	35.6%	51	27.6%	61	31.3%	$\chi^2 = 12.449^a$; df 8; Asymp. Sig. (2-sided) = .132
	Once in 3 months	15	25.4%	82	44.3%	80	41.0%	
	Once in 6 months	23	39.0%	52	28.1%	54	27.7%	
What package size of honey do you buy	1kg	27	45.8%	117	63.2%	95	48.7%	$\chi^2 = 1.736^a$; df 8; Asymp. Sig. (2-sided) = .023
	250g	13	22.0%	21	11.4%	27	13.8%	
	500g	19	32.2%	47	25.4%	73	37.4%	
What price do you pay for 1 kg of honey	5 euros	16	27.1%	70	37.8%	61	31.3%	$\chi^2 = 14.208^a$; df 8; Asymp. Sig. (2-sided) = .076
	5-10 euros	33	55.9%	100	54.1%	101	51.8%	
	More than 10 euros	10	16.9%	15	8.1%	33	16.9%	
Where do you most often consume honey	Directly from manufacturer	31	52.5%	111	60.0%	107	54.9%	$\chi^2 = 25.788^a$; df 20; Asymp. Sig. (2-sided) = .173
	Grocery shop	9	15.3%	16	8.6%	11	5.6%	
	Market/exhibition	13	22.0%	37	20.0%	59	30.3%	
	Monastery	0	0.0%	2	1.1%	5	2.6%	
	Organic product shops	3	5.1%	8	4.3%	7	3.6%	
	Supermarket (GOD)	3	5.1%	11	5.9%	6	3.1%	

Source: Created by the authors based on authors' survey within the project „Lime Trees & Honey Bees for Sustainable Development of the Danube Microregion” No: 6526-00/2011/Grant 64, the project is funded by the European Union and the Austrian Development Agency.

The Chi-square test showed a statistically significant difference in relation to the type of household as to the size of honey pack to be purchased ($\chi^2 = 19.792^a$, with $df=6$ and $p=.003$).

That is, it can be concluded that those households in which customers are adults who purchase honey for their children and for their children and their parents, purchase larger quantities of honey in comparison to households in which persons are single and purchase honey for themselves, as well as in households where the buyers of honey are teenagers.

When we compare the relationship between the price of honey and household type, we notice that persons who live alone and children (teenagers) who live with parents but purchase honey on their own are mostly those who set aside money for cheaper honey of up to 5 euros less than others, but twice as often save money for the most expensive honey with a price higher than 10 Euros.

The explanation of this lies in the fact that those who live alone have lower living costs compared to those who live in households, so they can save more money for themselves, and that, on the other hand, teenagers who most often receive money from their parents who they live with, do not give due weight to the price of the product they purchase. The Chi-square test confirmed the existence of a statistically significant difference in the relationship between the price of honey paid by customers and household type $\chi^2=50.949^a$, with $df=15$ and $p=0.000$).

When we observe the relationship between the place of purchase of honey and household type, we realize that the percentages of households in which parents buy honey and those where children buy honey are quite similar. Purchasing honey directly from producers and honey festivals is dominant in both cases, but it may be interesting to note that the percentages of purchases directly from producers and purchases at honey festivals in these two types of households are vry similar, compared to households where people live together with children and parents and to households where people live alone.

This in turn points to the fact that families with children, regardless of whether the customer is a parent or a child, have the same preferences regarding the place of purchase, in comparison to other types of households.

Table 5. CROSSTABS Do you have children or parents

	Do_you_have_children_or_parents												
	I have childrens and parents living in household			I have childrens living in household			I have no children and parents at home			I have parents living in household			
	Count	% within Do_you_have_children_or_parents		Count	% within Do_you_have_children_or_parents		Count	% within Do_you_have_children_or_parents		Count	% within Do_you_have_children_or_parents		
How_ofTEN_do_you_buy_honey	At least once a month	9	25.0%	57	31.1%	28	23.1%	53	33.1%				χ²= 12.105*;df6; ;Asymp.Sig. (2-sided) = .060
	Once in 3 months	19	52.8%	82	44.8%	45	37.2%	63	39.4%				
	Once in 6 months	8	22.2%	44	24.0%	48	39.7%	44	27.5%				
What_package_size_of_honey_do_you_buy_honey	1kg	23	63.9%	119	65.0%	60	49.6%	74	46.3%				χ²= 19.792*;df6; ;Asymp.Sig. (2-sided) = .003
	250g	5	13.9%	12	6.6%	20	16.5%	30	18.8%				
	500g	8	22.2%	52	28.4%	41	33.9%	56	35.0%				
What_price_do_you_pay_for_1_kg_of_honey	5 euros	17	47.2%	74	40.4%	32	26.4%	53	33.1%				χ²= 14.307*;df6; ;Asymp.Sig. (2-sided) = .026
	5-10 euros	16	44.4%	93	50.8%	72	59.5%	78	48.8%				
	More than 10 euros	3	8.3%	16	8.7%	17	14.0%	29	18.1%				
Where_do_you_most_ofTEN_consume_honey	Directly from manufacturer	14	38.9%	100	54.6%	84	69.4%	86	53.8%				χ²= 50.949*;df15; ;Asymp.Sig. (2-sided) = .000
	Grocery shop	0	0.0%	18	9.8%	12	9.9%	15	9.4%				
	Market exhibition	15	41.7%	49	26.8%	14	11.6%	42	26.3%				
	Monstery	0	0.0%	1	.5%	6	5.0%	1	.6%				
	Organic product shops	1	2.8%	5	2.7%	5	4.1%	7	4.4%				
	Supermarket (GOD)	6	16.7%	10	5.3%	0	0.0%	9	5.6%				

Source: Created by the authors based on authors' survey within the project „Lime Trees & Honey Bees for Sustainable Development of the Danube Microregion” No: 6526-00/2011/Grant 64, the project is funded by the European Union and the Austrian Development Agency.

Conclusion

Based on the results of this research, we have come to the conclusion that gender as a demographic characteristic can be completely neglected in defining the demographic profile and creating the marketing strategy of honey producers interested in the placement of honey on the market of Vojvodina. When it comes to age, i.e. the age structure of consumers, it has been found that there are statistically significant differences in the relationship between the size of packs, i.e. quantity of honey purchased and age. It has been noted that younger consumers, especially those under 20 years of age prefer smaller 500g packs of honey, compared to other age categories, particularly in relation to the category of consumers older than 60 who predominantly prefer 1kg packs. Although not statistically significant, from the aspect of creating a marketing strategy it is important to mention that there are certain differences when it comes to the ratio of the price of honey and age of consumers. Namely, it has been observed that elderly consumers older than 50, and especially those over 60 show certain preferences for honey with a lower price, which has been defined in our research as below 5 Euros. Therefore, the observed differences must be taken into account when creating demographic profiles and marketing strategies. Education is a demographic characteristic that is reflected in the differences in purchased pack sizes. Namely, all categories of consumers with the level of education of secondary school and above prefer 1kg packs of honey, while consumers with elementary school education prefer 500g packs. If we compare education to age, we come to the fact that young people who attend secondary school are those who would rather buy a 500g pack in comparison to other age and educational categories of consumers. The research has confirmed that household income is a factor that affects the differences in purchased pack sizes. Households with higher income prefer larger packs, whereas households with lower income prefer smaller packs. Household income does not reflect the price to a significant extent, which is also in relation to the place of purchase. Namely, considering the fact that all consumers regardless of income purchase honey directly from producers and given that they have built trust in the same they are willing to pay a medium price ranging between 5 and 10 Euros at which producers sell honey directly to customers, but they purchase larger or smaller quantities of honey depending on their income. Household type, i.e. the fact whether a person lives alone or his/her household includes children, or both children and parents, as well as whether the customer is a child or a person living with his/her parents and performs the purchase him/herself, proved to be

the demographic factor which most affects the differences among honey purchases. Our research has revealed that persons living in households with children or parents prefer 1kg packs of honey, while persons who live alone and children (teenagers) living with their parents prefer 500g packs, which is consistent with data showing that young people under 20 years of age and elementary school degrees mostly purchase 500g packs. It was also found that persons who live alone and children (teenagers) who live with parents but purchase honey on their own are mostly those who set aside money for cheaper honey of up to 5 euros less than others, but twice as often save money for the most expensive honey with a price higher than 10 Euros. This suggests that teenagers are those who will purchase smaller packs of honey at a higher price, while parents who take care of the entire household rather opt for larger packs at medium prices. When it comes to the place of purchase, it can be noted that although all types of households predominantly purchase honey from honey producers, the percentages of purchases directly from producers and percentages of purchases at honey festivals are quite similar for households where the customer is a parent living with children and where the customer is a child living with parents, in relation to other two types of households in which people live together with children and parents and in relation to households where people live alone. This in turn points to the fact that families with children, regardless of whether the customer is a parent or a child, have the same preferences regarding the place of purchase, in comparison to other types of households. Therefore, the examined sample of consumers showed that age, education and household income are factors that are of great significance when deciding on the size of packs, while household type is a factor that should be taken into account when deciding not only on the size of packs, but also the price and place of purchase, since it has been proven that there are statistically significant differences in behavior during purchases.

Literature

1. Ćirić, M., Ignjatijević, S., Cvijanović, D. (2015): Research of honey consumers behavior in province of Vojvodina, *Ekonomika poljoprivrede*, 62(3), pp. 627-644.
2. Grubić, R. (2008): *Beekeeping in Zrenjanin*, The work of the Museum of Vojvodina, 50, pp. 273-283.

3. Ignjatijević, S., Ćirić, M., Čavlin, M. (2015): *Analysis of honey production in Serbia aimed at improving the international competitiveness*, Custos e Agronegocio Online, 11(2), pp.194-213.
4. Kesić T. (2006): *Ponašanje potrošača*, Adeco, Zagreb.
5. Kotler, Ph., Vong, V. Sonders DŽ. Armstrong, G. (2007): *Principi marketinga*, Mate, Beograd.
6. Maričić B. (2008): *Ponašanje potrošača*, Ekonomski fakultet, Beograd.
7. Milisavljević, M., Maričić B., Gligorijević M. (2005): *Osnovi marketinga*, Centar za izdavačku delatnost Ekonomskog fakulteta u Beogradu, Beograd.
8. Novaković Rajačić, B. (2005): *Ponašanje potrošača*, Evropski univerzitet, Beograd.
9. Pelau, C. (2011): *Analysis of consumer behaviour for different product groups*, Management & Marketing, 6, pp. 101-114.
10. Pocol, C. B., Bolboacă, S. D. (2013): *Perceptions and trends related to the consumption of honey: A case study of North-West Romania*, International Journal of Consumer Studies, 37 (6), pp. 642-649.
11. Roman, A., Popiela-Pleban, E., Kozak, M. (2013): *Factors influencing consumer behavior relating to the purchasing of honey*, Journal of Apicultural Science, 57 (2), pp. 175-185.
12. Schiffman, G. L. and Kanuk, L. L. (2004): *Ponašanje potrošača*, Mate, Zagreb.
13. Solomon M. (1996): *Consumer Behaviour Buying Having and Bing*, Prentice Hall Inc, Englewood Cliffs, New Yersey.
14. Vanyi, G. A., Csapo, Z., Karpati, L. (2011): *Evaluation of Consumers'Honey Purchase Habits in Hungary*, Journal of Food Products Marketing, 17 (2/3), pp. 227-240.
15. Živković, R. (2011): *Ponašanje potrošača*, Univerzitet Singidunum, Beograd.

LOAN AGREEMENTS OF THE IFC IN THE PERSPECTIVE OF AGRICULTURAL FINANCING

Stefan Milanović¹, Jelena Ristić²

Abstract

International financial institutions, especially the International Finance Corporation (IFC), realize their contribution during the ending period of the global economic crisis, which has already increased the existing gap between the developed and undeveloped countries, by making a great number of investment arrangements, with the aim of fulfilling the increased demand for funds on the international market. By using the descriptive method as the dominant one, with the use of other legal and economical methods, the authors of the paper analyze funding of the agricultural sector (as a specific topic of this research), with an emphasis on the wide range of activities of this international institution (from small farms to infrastructural projects in agriculture), the financing subject of which concentrates on: financing farmers and agricultural entrepreneurs, traders, exporters and other entities; financing the expenditures in the value chain of agricultural subcontractors; realization of infrastructure agricultural facilities and providing advisory services etc. As far as this paper is concerned, the authors' intention is to clearly point out the specificity of IFC financing, with an emphasis on methodology and significance of financing the agricultural sector, with the aim of creating sustainable agricultural growth in Member States.

Key words: *IFC, loan agreements, the agricultural sector.*

Introduction

The end of the last global economic crisis increased the existing large gap between the developed countries and the developing countries (especially the undeveloped countries), which has affected greater activity of

¹ Stefan Milanović, Assistant, Business School of Professional Studies Blace, email: stefikaner84@gmail.com, 063/404113.

² Jelena Ristić, PhD, Professor, Business School of Professional Studies Blace, email: jelenazristic@yahoo.com, 063/404202.

international financial institutions, that is, the International Monetary Fund and the World Bank. Financial operations of the international financial institutions imply concluding agreements between countries and/or private business entities with companies with headquarters on the territory of Member States, on the one hand, and international organizations, which apply contractual or other rules of both the public international law and the rules of international trade law and economic law, on the other hand.

Accordingly, the question which arises is the one of the character of international-legal obligations of these institutions in planning, estimating and implementing projects, as well as in activities or policies of sustainable economic development which they are funding.

The International Finance Corporation (hereinafter referred to as IFC), as a specific entity of the World Bank, has realized a large number of investment arrangements with private companies throughout the world in order to answer to the increased demand of funding on the international capital market. Considering the significance and the influence of business arrangements of IFC, it is necessary to analyze in greater detail the implications of loan agreements of this institution, both the general implications of credit agreements of this institution and their influence and significance for the agricultural sector.

In relation to that, implications of the loan agreements of IFC can be viewed primarily from the perspective of the institutionalized position of this institution. Besides that, it is necessary to determine and define the investment forms of IFC, with the aim of determining the legal framework for concluding concrete loan agreements, as well as new forms of investments in the agricultural sector. In accordance with that, it is important to point out that these agreements differ from the loans of other institutions of the World Bank (IBRD and IDA), which implies other types of concrete loan arrangements.

Institutional Position of the International Finance Corporation

As a separate subject of international law, IFC has a *dual* nature (Bradlow, 2010, p.5). On the one hand, it represents an intergovernmental organization, founded by countries, by concluding the international agreements (*Articles of Agreement of the International Finance Corporation*, Dec. 5, 1955), for accomplishing specific *public goals*

(improving economic development by encouraging growth of private companies in Member States, especially in less developed areas), which bases its laws and obligations on the existing principles of the international law (7 U.S. TREATIES & OTHER INT'L AGREEMENTS 2197, T.I.A.S. No. 3620.). On the other hand, the participation of this organization in financial transactions, which are used for realizing the proclaimed public purposes, is based on the *commercial principles* of the classic market financial transactions. Initiating the formation of this organization is linked to the so-called Rockefeller Commission Report, passed by the United States International Development Advisory Board, which proposed the basic legal and economic principles of IFC functioning (Glazer, 1957, p. 1092).

In order for a country to become a member of this institution, it first needs to become a member of the International Bank for Reconstruction and Development (IBRD), sign the Articles of Agreement (IFC's Articles of Agreement) and to deposit the instrument of acceptance of the Articles of Agreement at the World Bank Group's Corporate Secretariat. Formally, IFC is an independent legal entity, independent of other institutions of the World Bank (IBRD, IDA, MIGA and ICSID), although it shares the structure with the aforementioned organizations.

Moreover, IFC may be characterized as the largest multilateral development institution, the activity area of which is mostly focused on the private sector in developing countries. Business operations of IFC are conceptually aimed at developing countries, with special emphasis on the allocation of funds on productive private companies, with special focus on agriculture, infrastructure, production, services and financial markets, etc.

An important feature of IFC is seen in its independent funding of its business operations. IFC on the market of Member States *de facto* has the so-called Preferred Creditor Status, which represents the obligation of the Member State to enable privileged access to foreign currencies by loan agreements with IFC, in situations when a country is facing a foreign exchange rate crisis (Duque, 1998, pp. 301-302). Although this feature is not of a formally legal character, it must be emphasized that it has been confirmed several times in practice (Pakistan, 1998; Russia, 1998; Argentina, 2001).

Forms of Investment Realizations of the International Finance Corporation

According to the regulations of Articles of Agreement, IFC can invest its funds in the form which the institution itself assesses to be appropriate (Article 3, Sec. 2). It is interesting to point out that this regulation is not contained in the basic version of the Articles of Agreement, because the USA was against granting the IFC the right to obtain ownership shares in private companies (Matecki, 1956, pp. 264-269). Still, the clarification of the notion “investments” can only generally be found in the regulations of the Articles of Agreement, in the part which refers to other operations of this institution (Article III, Sec. 6). In that sense, IFC can invest funds in private capital and investment funds, such as index and land funds, and also into funds with risk capital, provided that it accepts investment standards and requests of this institution. In relation to that, it is necessary to clearly point out that IFC, in the greatest number of cases, does not directly fund interested business partners, but does this indirectly, that is, through specific types of financial mediators (investment funds, commercial banks, insurance companies, etc.), which direct the approved IFC funds to end users.

Contrary to IBRD, which possesses the relevant legal regulations for concluding concrete business arrangements (eg. *IBRD General Conditions for Loans*, March 12, 2012), the business practice of IFC has defined specific conditions which investment projects need to fulfill, in order to be adequate for investment. Primarily, in most cases, these projects need to be realized in developing countries, as well as to be technically feasible. Also, there need to be “good prospects” of project profitability, as well as the contribution to the development of domestic economies. What IFC should specifically insist on refers to the request that a specific project must be ecologically and socially acceptable, that is to fulfill the standards of ecological and social protection, both of IFC and the host country. However, besides the assessment of the general economic justification of the project, it needs to be emphasized that IFC does not invest in companies on the territory of Member States which oppose such methods of financing, nor does it fund projects which refer to the procurement of certain products (prohibited by domestic laws or international agreements, such as pharmaceutical products, weapons, tobacco, alcohol, with the exception of beer and wine, etc.).

In the area of investment in the agricultural sector of the Member States, IFC applies the so-called sectoral concept, which implies the financial services for agricultural production, processing and marketing, which include short-term, medium-term and long-term loans, leasing and payment services, as well as the insurance of livestock and crops. For instance, one of the business programs of IFC for agricultural financing, The Global Warehouse Finance Program (GWFP), created in 2010, enables concluding short-term loans for financing farmers, producers of agricultural products or traders of these products. Depending on the payment methods of loan funds or methods for obtaining them, investment in the agricultural sector can be classified into three categories: loans for farmers (directly or indirectly), financing on the basis of pledge of movable property, as well as financing based on the income of buyers, as a source of repayment of credit funds.

Nevertheless, business operations of IFC, the final goal of which is short-term or long-term loans to the private sector, are realized through a series of business transactions, which can formally, in legal terms, be expressed as loan agreements, guarantee agreements, risk share agreements, as well as capital investment agreements. It must be emphasized here that guarantee operations of IFC, although various (such as GOLF or trade guarantees etc.), do not play a significant role on the international capital market, for the reasons that the Multilateral Investment Guarantee Agency (MIGA) originally deals with this activity.

Legal and Economic Characteristics of Credit Arrangements of the International Finance Corporation

IFC loan agreements, as the main method of realizing business operations of this international financial institution, represent a complement of credit instruments of other financial institutions of the World Bank Group (IBRD и IDA), the specificity of which arises from the commercial manner of this institution's operations and the entities with which IFC concludes the mentioned agreements.

The primary source of IFC contract law, which is applied to all credit arrangements which this institution realizes, represents the Article of Agreements with this institution, which also has the role of the organization's statute. On the other hand, as secondary sources of contract law for concluding loan agreements, various bylaws of these institutions

are applied (rule books, decisions, operation regulations, established practice of organizations etc.).

Principally observed, the general conditions of IFC financing (as well as other regulations of bylaw acts of this institution) are not a precondition for concluding a credit arrangement with this institution, which means that the private-legal entities may be obliged by the regulations of these conditions only in an agreement reached in advance about their incorporation in loan and guarantee agreements with this institution. Otherwise, these bylaw acts represent instruments of an international organization which are used for recommending undertaking of specific legal actions (Virally, 1990, p.171). However, in the case of incorporation, these conditions regulate the rights and obligations of the contract parties as the constituent part of main contracts and they acquire the status of an international agreement, whereas in the case of disagreement of regulations of the loan agreement and general conditions for financing, the norms of the concluded loan agreement are applied.

In terms of the sustainability of debtors who may conclude a loan agreement with IFC, there are no specific limitations. This practically means that any private company on the territory of the Member State has the right to use IFC funds, from 1 to 100 million dollars, considering that, in practice, this is the limit for individual loan operations of this financial institution.

On the other hand, on the side of the creditor's loan funds, IFC may act independently, as the only creditor of the debtor, but also together with other creditors. That means that in terms of the manner of collecting funds necessary for the realization of a specific project, besides IFC's funds, there is a possibility of direct or indirect participation of institutional investors (private or public) in the funding of a specific business operation. Also, the stake subject of institutional investors may be in the form of cash assets, but also in the form of investment portfolio, which is comprised of various types of securities and other property forms.

Nevertheless, the realization of IFC credit arrangements is performed in the form of short-term and medium-term loans, with the maturity date of 7 to 12 years (in exceptional cases the maturity date can be extended to 20 years), with the possibility of denomination into a large number of world currencies (although in most cases the American dollar is used), whereas the interest rate for these credit arrangements (which are mostly variable

and linked to *LIBOR* or *EURIBOR* interest rates) depends on the market conditions, as well as the risk assessment of the Member State and the exploitability of the project itself.

In terms of the financing of the agricultural sector, it should be noted that funding is subsidized in a great number of Member States, which excludes the possibility of direct crediting of end users. Due to these circumstances, the transfer of the approved loan funds is carried out through a specific financial mediator (usually a commercial bank). In the Member States where the regulations of the domestic law do not allow loans for the agricultural sector, IFC performs its business operations according to the regulations of the Collateral Management Agreement (CMA) or the Stock Monitoring Agreement (SMA).

In accordance with the aforementioned general characteristics of the loan agreements of IFC, it is necessary to further perform the determining of specific contract forms which this institution concludes in performing its business operations. Based on the available material of IFC, which are rather lagging in terms of transparency, it is believed that the contract arrangements of IFC can be realized in five specific forms:

Classic loan agreements. These IFC agreements represent financial contracts with private companies, which this financial institution concludes and conducts, exclusively, in its own name and for its own account, by using its own funds. In relation to this, the independence of IFC implies the absence of other creditors on the side of the creditors in relation to the users of funds, which gives this institution the property of the primary creditor in relation to the debtor. This practically means that the claims of IFC are of an authorized nature, that is, they have the right of priority of collection in relation to other creditors, which is the reason why these loans are called *A-loans* in business practice.

The realization of this type of loans is performed through financial institutions of the country debtor, in accordance with the rules of the financial policy of a specific country. In this way, the provided funds can be used for the implementation of a certain policy, such as promotion and improvement of production in small and medium-sized companies which invest in agriculture and other industries. The agreement determines the amount of funds, it is primarily approved for domestic financial institutions, which are, on the second level, to end users.

Because of the realization methods, these loan instruments are called “two-step loans” because, in the realization process, the funds go through two or more financial institutions before the end users receive the allocated funds. In the first step, IFC (in cooperation with IBRD, MIGA, IMF, multilateral development banks and other donors) comprises a loan construction for financial intermediation and it directs funds to domestic financial institutions (financial mediators). Funds which these institutions direct to financial mediators (domestic financial institutions) can be in the form of loans or equities. In the second step, financial mediators direct funds to end users by financing projects which aim at increasing the production of goods and services, also in the form of loans or equities. Second step projects must fulfill development and suitability criteria of IFC, whereby this institution, in accordance with the agreement with first step debtors (financial mediators), monitors the fulfillment of the requested criteria for the realization of second step projects. However, in this situation it should be considered that this financial organization does not invest equities in financial mediators or end users of loan funds.

The financial mechanism of these loans enables long-term funding of domestic financial institutions, which fulfill the investment needs of the real sector; in this way, the funds can be approved for numerous end users in the private sector. At the same time, for each individual project which they fund, domestic financial institutions take over the credit risk. For this reason, these loans are expected to enhance the operative capabilities of domestic financial institutions, as well as to influence the development of the financial sector of the debtor countries.

In accordance with the general characteristics of credit arrangements of this financial institution, as previously pointed out, the maturity dates for individual loans of IFC range from 7 to 12 years, whereas the grace period and repayment schedule are determined on a case-by-case basis, depending on the financial needs of the funds users. In certain cases, when, according to IFC standards, business justification of a project needs to be proved, the maturity date and the grace period may, by IFC’s unilateral decision, be extended to 20 years the most.

In terms of the amount of funds which IFC approves, it should be pointed out that this financial institution usually limits these amounts to 25% of the *total* estimated costs for *green-field* projects, while under exceptional circumstances, for smaller projects, the amount of approved loan funds can amount up to 35% of total costs. However, in the so-called *expansion*

projects, IFC can participate up to 50% in project costs, under the condition that a specific investment does not exceed 25% of the total capitalization of a project company. In specific cases, the amounts of individual loans, as already stated, range from 1 to 100 million dollars, but in the business practice of IFC, it is being considered that these funds be extended to loans which are repayed only by the project's cash flow, without the use or only with the limited use of cash assets from other investors.

IFC's business policy allows the participation of countries and other private business entities in the realization of a specific individual loan, but only *after* the conclusion and beginning of realization of a loan agreement with the debtor.

Syndicated loans. As far as syndicated loans are concerned, it should be emphasized that they present a specific form of a loan whereby the IFC participates with several creditors in financing a certain business project (usually of great value), where IFC performs together with other creditors in relation to the debtor. This practically requires the existence of *several legally individual loan agreements*, which the debtor concludes with each creditor respectively (including the IFC), and where there is no joint accountability of the creditor for executing obligations of another participant of a specific loan operation (Aster' & Attaway, 2015-2016, pp.868-870). Structurally speaking, the realization of direct joint loans consists of a series of business operations, which, in our opinion, can be divided into two phases.

In the first phase, the debtor (a private company with headquarters on the territory of the member state) entrusts to IFC the organization of business operations for the collection of necessary funds from several financial institutions, which means that this international financial institution takes the position of the leading bank (*arranger*). By accepting the organization of this business operation, IFC takes over the responsibility to comprise an agreement draft of the term sheet, the memorandum, which includes important information about the assessment of the economic viability of the debtor, as well as the draft agreement, which the debtor signs *individually* (bilaterally) with all creditors who accept the terms agreed upon (Mugasha, 2007, pp.44-52).

In relation to this, the business practice and theory have identified three types of clauses which the leading bank (in this case the IFC) can

implement in the *offer* which it gives to the debtor, and it concerns the obligation of collecting funds for: 1) fully underwritten clause, when the IFC takes over the obligation to provide and pay the *total* amount of the necessary loan funds; 2) partially underwritten clause, according to which the obligation of the IFC is limited to providing *partial* amount of funds; and 3) the best efforts clause, when the IFC takes over only the obligation for investing the reasonable efforts for positioning loans on the capital market (without the obligation of collecting funds), with a possible increase in the total loan amount, if it comes to the founding of a loan association (Mugasha, 2007, pp. 44-52).

The second phase of realizing direct joint loans refers to the beginning of the payment of the agreed credit funds to the debtor, when the IFC's role as the leading bank of direct joint loans ceases, based on the mutually concluded contract between the creditor and the IFC, a loan association is created, where the IFC takes over the role of an administrative agent, the obligations of which refer to the representation of members of the loan association and performing other administrative functions, necessary for the realization of a complete credit arrangement of this type of loan (Donaldson, 1979, p. 76).

As an administrative agent, the IFC can perform various business functions, the most important of which refers to the organization and collection of funds and their payment to the debtor, control of the fulfillment of credit conditions of all creditors, monitoring financial abilities of the debtor, coordination and management of voting among members of the loan association, as well as creditor's reporting about all aspects of the realization of a specific credit arrangement.³

According to the aforesaid, it can be concluded that this type of loan within the framework of the IFC, which has been applied from relatively recently (after the last global financial crisis), expands the possibility of borrowing funds from development financial institutions, commercial

³ Cooperation with development financial institutions has significantly increased in the period of the global financial crisis, due to the lack of liquidity of commercial banks, which is the reason why, in October 2009, IFC signed the General Agreement on cooperation with three largest development financial institutions: DEG (ger. *Deutsche Investitions- und Entwicklungsgesellschaft*, eng. *German Investment and Development Corporation*), FMO (ned. *Financierings-Maatschappij voor Ontwikkelingslande N.V.*, eng. *Netherlands Development Finance Company*) and Proparco (fra. *Société de Promotion et de Participation pour la Coopération Economique*).

banks, investment funds, insurance companies and it enables longer maturity dates for repayment of total loan amounts.

Participatory loan agreements. The category of participatory loan agreements, the realization mechanism of which implies the conclusion of a loan agreement, exclusively, between the main creditor (in this case the IFC) and the debtor (a private company), while the rights and obligations between the IFC and other creditors are regulated by the Participation Agreement in the joint loan project.

Practically speaking, when a certain project is funded by participatory joint loans, in which the IFC participates as the main creditor, a certain amount of funds, which this institution should provide, is invested in its own name and for its own account in the form of independent loans (*A-loans*), with identical conditions which are applied in their realization, while the remaining required amount is sold to other interested creditors, usually by issuing debt securities. Funds of other creditors, collected in this way and included in the funding of a certain project, are marked as *B-loans* in business practice, while the method of payment of these funds is agreed upon with IFC and these conditions of payment are included in the loan agreement with the debtor (which, in our opinion, additionally raises the price of the loan). For this reason, we believe that in the financial construction of participatory joint loans, a *dual* character of conditions for payment of the total amount of loan funds plays a role (the conditions of payment of the IFC, on the one hand, and the conditions of payment for other creditors, on the other hand).

In substantive legal terms, the participation of other creditors in the system of participatory joint loans of the IFC, implies the allocation of *quotas of participation* to each creditor, in the total amount of loan funds, which can be realized in three ways. Firstly, the main creditor (IFC) can use a cession to concede a certain participation share in the loan to other creditors, when a direct relation between the debtor and another creditor is being created (Carver, 1985, pp.311-314). In addition, the main creditor may *borrow* a certain amount of funds from other creditors in exchange for participating in the loan, when it does not come to establishing direct relations between other creditors and the debtor (Wood, 2007, pp.173-174).

In order for a certain financial institution to participate in the funding of the mechanism of participatory joint loans, it must acquire the status of an

eligible financial institution which, according to the established business practice of the IFC, implies the fulfilment of three *cumulative* conditions:

- it must not be an official public agency (such as, for example, an export credit agency), quasi-public or multilateral agency;
- it must have at least one investment long-term foreign currency rating, according to the rules of *Standard&Poor's*, *Moody's Investors Services* or *Fitch Ratings* rating agencies; and
- it must not be founded, or have the headquarters in the headquarters country of the debtor (private companies), as well as a branch in the debtor's country.

It is important to note that the IFC loans, including the ones with the participation of financial institutions, never include in the general plan the restructuring of public debts, nor have they ever been the subject of new financial obligations of a country, according to the agreed plan for restructuring debts.

Portfolio loan agreements. Portfolio loans represent complex credit arrangements of the IFC, which are invested in accordance with the regulations of the Managed Co-Lending Portfolio Program (MCP), passed at the end of 2012, within which the funds for crediting business operations of the IFC are provided, both the private and the public institutional investors, by transferring the management rights by its own *investment portfolio* to the IFC. In relation to this, the investment portfolio, which is passed over for management to the IFC by the interested investors, represents a set of short-term and long-term securities (shares, bonds, financial derivatives, shares in investment funds, etc.), with the aim of decreasing investment risks and increasing their own profits.

In order for a certain investment portfolio to be passed over for management to the IFC, an Administration Agreement needs to be concluded between this financial institution and the interested institutional investors. Upon signing the agreement, the total investor's portfolio is transferred to an account created for that purpose, of a specific trust fund, managed by the IFC and which directs the entrusted funds into crediting private entities in Member States. In this situation, the end user of these funds (the borrower) is in a *direct* relationship exclusively with IFC and signs only *one* loan agreement with this financial institution. However, this loan agreement of the IFC with the debtor is signed *twice*: first, in its

own name and for its own account, and the second time, as an implementation agency for a trust fund (Berla, 2013).

In this type of credit instruments, the *IFC* is the only one which plays an *active* investment role and it has the complete freedom in unilateral decision-making on the *placement* of funds of the stocked investment portfolio, which means that these funds are used for its own business operations throughout the region, in accordance with its own strategy, goals and business evaluations.

However, although the IFC manages the realization of the project fully, the investor's funds (from the stocked portfolio) are paid to the debtor only after approving the payment by the investor (*Partnering with IFC Syndications*, 2012.). Besides that, the IFC is obliged to invest the investor's funds according to previously set criteria, with the consent of the debtor in each credit transaction.

Blended loan agreements. As far as blended loans are concerned, it is necessary to point out that this type of credit arrangements represents the only type of IFC's business operations, the realization of which implies a concessional component, both in investing and in repaying the total amount of approved funds.

Namely, the basic principle for the realization of these loans refers to the use of the donor's funds with the aim of *attracting private capital*, for financing *development* investment projects in member states with undeveloped markets, that is, emerging markets. In this case, the donors strategically use their funds for *reducing investment risks* and *increasing profits* of private investors, which implies directing funds of private investors to specific development sectors. For instance, according to certain points of view, the use of *public* capital in such transactions can attract up to a ten times greater amount from the starting capital through private investments (*Blended Finance*, 2015, p.8).

It should be emphasized that this type of an IFC loan is realized only in situations when such investments can lead to commercial sustainability, usually in the period from 5 to 8 years, while the financial compensation to private investors is realized in accordance with the market expectations,

based on the actual and expected risks.⁴ Besides that, the structure of mixed loans implies lower interest rates, the use of instruments for risk share, longer maturity dates, as well as placing loans with lower degrees of payment priority.

Based on the aforesaid, it can be concluded that the funds invested in the form of mixed loans, formally do not present a subsidy, but a certain form of a *donor investment*, which alleviates the challenges of market obstacles.

IFC Financing of the Agricultural Sector and its significance

Financing of the agricultural sector includes a wide range of activities, from small farms to infrastructural projects in agriculture. The subject of this financing refers to: 1) crediting farmers and agricultural entrepreneurs, traders, exporters and other entities; crediting input import (eg. seed and fertilizers), production (eg. machines and equipment), marketing (eg. processing, packaging and transport of products) etc.; 2) financing expenditures in the value chain of agricultural subcontractors, 3) realization of infrastructure agricultural facilities and 4) providing advisory services.

Agricultural financing models:

- *Direct financing* of entities in the agricultural sector, which includes crediting, leasing and factoring affairs, insurance from time risks and schemes of group guarantees (eg. for most farmers who individually do not fulfill the conditions), financing by farmers' savings and various forms of inclusive micro financing;

- *Indirect crediting*, the so-called "wholesale model", implies the crediting of small and medium-size enterprises joint in agricultural cooperatives or other forms of cooperations. In this case, the credit debtor is the cooperative, while the members guarantee each other to carry out the obligations;

- *Value chain financing*, which implies interrelations among the suppliers, buyers, producers and banks, refers to financing financial transactions between entities in a row (suppliers, producers, etc.). There are two types of this way of financing, the internal financing, which includes financing production, trade, import-export and other loans, (eg. when the utility

⁴ IFC has approved 407 million dollars of concession funds for investment and advisory projects since 1996, while more than a total of 4 billion dollars has been collected.

company performs the billing of costs for various services after the harvest of the agricultural producer) and the external financing, in which case the costs in the value chain are covered by the bank, which does not present the component of the series;

- *Infrastructural financing* – the road network for connecting isolated areas with the market for agricultural products and services; construction of irrigation systems and storage capacities for the protection of harvest from the weather conditions and pests; telecommunication systems for efficient trade, the construction of electrical and water capacities etc. The most common form of this type of financing is represented by models of public-private partnerships, such as service agreements, management and leasing agreements, concessions and VOT investment models, and in some cases the whole ownership of the private investors. Collecting the necessary funds for these projects are realized in different debt, capital and other mechanisms for avoiding business risks, and there is a possibility for including commercial and development banks, institutional investors, countries, etc.

Credit cooperation of the Republic of Serbia and the International Financial Corporation in the Area of the Agricultural Sector

In the area of agricultural production, the IFC concluded an agreement about an investment loan with the domestic company Victoria Group a.d for financing reversible capital and long-term restructuring of company debts (<http://ifcextapps.ifc.org/>, project no. 31072). Financing of this project is carried out by the IFC through an independent loan for the amount of 74.13 million dollars, by direct payment of funds to the domestic company, without the mediation of financial companies.⁵ The funds are intended for long-term financing, providing financing investments of farmers for production of food and oil crops (and their processing). A six-year credit arrangement of the IFC will be of use to Victoriaoil, Sojaprotein, Victoria Logistic and Fertil, business companies which perform business activities within Victoria Group a.d. Belgrade, for financing all agriculture phases.

An agreement on investment crediting with the domestic company MK Group d.o.o was concluded, the so-called *Project Sava*, for funding vertical and horizontal spreading of business activities of a company in

⁵ The project was approved on November 19, 2012 and IFC has paid 74,13 million dollars up to now.

new sectors, primarily in agriculture (sugar factory, improving agricultural infrastructure). In this project the IFC participates in the form of an independent loan, the value of 55.82 million dollars (<http://ifcextapps.ifc.org/>, project no. 31667).⁶

In the area of industrial production, the IFC concluded an investment agreement with the domestic company VINO ZUPA AD,⁷ which is realized in the form of an independent loan of the IFC for financing capital investments of 12 million euros, which includes investments in the additional process of bottling, capacities of fruit concentrates and investment in the energy block of 3 million euros (<http://ifcextapps.ifc.org/>, project no. 31867). In addition to this, for fulfilling standards for health, social and protection of the environment of the IFC in EU, 1.5 million euros were provided, from the amount of which for extending capacities for bottling and production of fruit concentrates (3 million), improving the work quality of the plant for waste water treatment (1.5 million), refinancing a part of the existing long-term loans (6 million) and providing permanent current assets (2 million).

UniCredit AGRI project is realized in the form of a “higher” loan (the debtor primarily repays the debts to the IFC according to this loan, without considering other creditors), whereby the IFC lends funds to a domestic company, UniCredit Serbia AD, for funding the agricultural sector and easier access to mortgage loans for the poor population. This project was approved on August 5, 2011, for the amount of 55 million euros (<http://ifcextapps.ifc.org/>, project no. 30669).

The IFC approved a loan of 70 million euros in June 2012 for „Societe Generale Serbia“ bank. This loan is intended for financing agriculture and the support for economic development, employment and export, considering that 45% of the population in Serbia lives in rural areas and a third of population depends on agriculture.

Conclusion

Business activities of the IFC, as the largest multilateral development institution, are conceptually directed towards developing countries, with a

⁶ The realization of investment activities of the IFC has started in August, 2012.

⁷ The Board of executive managers approved the realization of funds on December 3, 2012, and 16.52 million dollars have been paid.

special emphasis on the allocation of funds to productive (production) private companies, with a particular focus on agriculture, infrastructure, production, services and financial markets, etc.

In the area of the agricultural sector investment of a member state, the IFC applies the so-called sectoral concept, which implies financial services for agricultural production, processing and marketing, which includes short-term, medium-term and long-term loans, leasing and payment services, as well as the insurance of livestock and crops. The Global Warehouse Finance Program (GWFP), is one of the IFC business programs for agricultural financing, created in 2010.

However, as far as the agricultural sector funding is concerned, it should be noted that this sector is in a great number of member states subsidized, which excludes the possibility of direct loans to end users. Due to these circumstances, the transfer of approved loan funds is carried out through a specific financial mediator (usually a commercial bank).

Through the analysis of the credit arrangements of the IFC, as well as the realized projects, we have arrived at the conclusion that this development institution has an exceptional significance for the development of agriculture in the Republic of Serbia, where 45% of the population lives in rural areas and a third of the total population depends on agriculture.

Literature

1. Aster' E. C. and Attaway, A. M., *Syndicated Construction Loans, Defaulting Lenders and Equitable Remedies*, 48 Tex. Tech L. Rev. 853 2015-2016, pp. 868-870.
2. Berla, S., (2013): *Attracting New Liquidity*, ECA Conference, Paris.
3. *Blended Finance Vol. 1: A Primer for Development Finance and Philanthropic Funders*, ReDesigning Development Finance Initiative, A joint initiative of the World Economic Forum and the OECD, World Economic Forum, September 2015, p. 8.
4. Bradlow, D., (2010): *International Law and the Operations of the International Financial Institutions*, American University Washington College of Law, Washington College of Law, p. 5.

5. Carver, Jeremy P., (1985): *The development of market in participations in syndicated loans and acceptance credits: some legal pitfalls and their solution*, y: Pierce, D.G., Chan, H., Lacroix, F.E., Pillai, P.N.: *Current issues of international financial law*, Malaya Law Review and Butterworths, Singapore, pp. 311-314.
6. Cvijanović, D., Ignjatijević, S., Milivojević, I., Mihailović, B., (2016): *Potencijali Srbije u međunarodnim okvirima - značaj poljoprivrede i zdravstvenog turizma*, Monografija, Fakultet za hotelijerstvo i turizam u Vrnjačkoj banji.
7. Cvijanović, D., Popović, V., Subić, J., Paraušić, V., (2013): *Stanje i mogućnosti razvoja održive poljoprivrede i ruralnog razvoja u podunavlju*, Monografija, Institut za ekonomiku poljoprivrede Beograd.
8. Donaldson, T. H., (1979): *International lending by commercial banks (International banking series)*, Macmillan, London, p. 76.
9. Duque, F. C., (1998): *Co-Financing with IFC: Preferred Creditor Status and Inter-Creditor Agreements*, 26 Int'l Bus. Law 300, pp. 301-302.
10. Glazer, H. J., *A Functional Approach to the International Finance Corporation*, Columbia Law Review, Vol. 57, No. 8 (Dec., 1957), p. 1092.
11. Matecki, E. B., *Establishment of the International Finance Corporation: A Case Study*, International Organization, Vol. 10, No. 2 (May, 1956), pp. 264-269.
12. Mugasha, A., (2007): *The law of multi-bank financing, Syndicated Loans and the Secondary Loan Market*, Oxford University Press, pp. 44-52.
13. *Partnering with IFC Syndications*, September, 2012., www.ifc.org (03.09.2016).
14. Virally, M. (1990): *Le droit international en devenir: essais écrits au fil des ans*, Politique étrangère, Volume 55 Numéro 2, The Graduate Institute, Geneva, p. 171.

15. Wood, P. R., (2007): *International loans, bonds, guaranties and legal opinions, 2nd edn*, The Law and Practice of International Finance Series, Vol. 3, Sweet & Maxwell, London, pp. 173-174.
16. International Finance Corporation, <http://ifcextapps.ifc.org/> (06.09.2016).
17. Global Warehouse Finance Program,
18. http://www.ifc.org/wps/wcm/connect/Industry_EXT_Content/IFC_External_Corporate_Site/Industries/Financial+Markets/Trade+and+Supply+Chain/GWFP/ (10.09.2016).

IS IT TIME FOR FAIRTRADE MILK IN SERBIA?

Tatjana Brankov¹, Koviljko Lovre²

Abstract

Serbian milk sector facing a number of challenges which results in a higher prices for consumers and the gray market zone. The paper gives a portrait of Serbian milk production sector as well as historical description of Fairtrade, geographical scope of Fairtrade, and an explanation of the basic difference between Free trade and Fairtrade. In order to prevent the disappearance of small family farms and their replacement with large-scale farms we propose the introduction of Serbian Fairtrade milk scheme.

Key words: *Milk sector, Fairtrade, Minimum price, Premium price.*

Introduction

The deep roots of modern Fair trade lie in old moral economy. E.P. Thompson, a British historian, writer, socialist and peace campaigner in his work on 18th century England, described the moral economy of the poor during the transition to industrial capitalism in England where “notions of common well-being, often supported by paternalistic traditional authorities, imposed some limits on the free operations of the market”. The moral economy of provision asserted that farmers were not allowed to withhold their produce from local markets to wait for prices to increase and that the action of middleman were legally suspect and restricted (Fridell, 2007).

During the interwar period (1918-1939) in advanced capitalist countries of the North a global economic recession caused an overall decline of demand and a rapid decline in the price of primary commodities such as:

¹ Tatjana Brankov, PhD, Assistant Professor, University of Novi Sad, Faculty of Economics, Segedinski put 9-11 Subotica, Tel:+381641021696, E-mail: tatjana.brankov@ef.uns.ac.rs.

² Koviljko Lovre, PhD, Full Time Professor, University of Novi Sad, Faculty of Economics, Segedinski put 9-11 Subotica, Tel:+38124628025, E-mail: klovre@ef.uns.ac.rs.

copper, tin, rubber, coffee, wheat, sugar, and cotton in relation to secondary, manufactured goods. The role in price decline had also the development of substitutes for primary products, and an expansion of capacity by Southern producers for goods whose markets were already saturated. As a solution for protecting profits of colonial companies and in order to prevent possible collapse of the international trading system colonial powers in Europe conducted various attempts to control international commodity markets. A series of control schemes for primary commodities (restricting output, stockpiling to keep commodities off the market and raise prices) were established for primary commodities throughout the 1920s and 1930s. The Canadian Wheat Pool was the best known (Skidelsky, 2005). In Canada in 1923 and 1924, three wheat pools were created as farmer-owned co-operatives, created to break the power of the large for-profit corporations, that had dominated the grain trade in Western Canada since the late 19th Century, and were an early source of Western alienation. The wheat pools were successful grain traders and marketers from 1923 to 1929. During the Great Depression huge losses forced them out of the grain marketing business. Also other control schemes failed because “the higher prices which resulted merely encouraged new producers to enter the market or led to intensified efforts to develop more substitutes in the North” (Fridell, 2004).

The Second World War (1939-1944) reduced primary production in Europe, East Asia, and parts of Africa and caused rise in the price of primary commodities in relation to manufactured goods. The Allied powers negotiate the Bretton Woods system, International Monetary Fund (IMF), and the International Bank for Reconstruction and Development (IBRD) were formed as well as the General Agreement on Tariffs and Trade (GATT) come into force. Post-war development brought decline in the price of the primary commodities and new commodity schemes have occurred for low demand elasticity commodities. Under United Nations (UN) auspices five international commodity agreements were signed by producing and consuming countries: The International Sugar Agreement (1954), Tin Agreement (1954), Coffee Agreement (1962), Cocoa Agreement (1972) and Natural Rubber Agreement. As presented in Table 1 all those agreements have proven unsustainable, and failed to increase the export earnings of nations in the South for a variety of political-economic reasons (Fridell, 2004). For example, The International Sugar Agreement signed in 1954 was designed to stabilize prices between exporting and importing countries, but it collapsed when the U.S. unilaterally boycotted Cuban sugar.

Table 1. *International commodity agreements*

	Sugar	Tin	Coffee	Cocoa	Rubber
Date	1954	1954	1962	1972	1980
Status	Collapsed in 1963 and 1983	Collapsed in 1985	Suspended in 1989	Suspended in 1980	Suspended in 1996
Number of agreement	4	6	4	4	3

Source: *Varangis et al. (1996)*

Failure of commodity schemes resulted in the first UN Conference on Trade and Development (UNCTAD) in 1964. The slogan “Trade not Aid” was launched accompanied by demand of a greater transfer of wealth from the North to the South through compensation and fairer trade focused on weakening the protectionist measures of the rich countries tariffs, import controls, levies and replacement of financial aid provided by the IMF by a system of subsidies for primary producers. “Trade not Aid” also become the slogan of the Fair trade network.

What is Fair trade?

FINE, created in 1998, an informal network with no decision-making power involves the Fairtrade Labelling Organizations International (FLOI), the International Federation for Alternative Trade (IFAT), the Network of European Shops (NEWS!) and the European Fair Trade Association (EFTA) has defined Fair Trade as follows:

Fair Trade is a trading partnership, based on dialogue, transparency and respect, that seeks greater equity in international trade. It contributes to sustainable development by offering better trading conditions to, and securing the rights of, marginalized producers and workers –especially in the South. Fair trade organizations (backed by consumers) are engaged actively in supporting producers, awareness raising and in campaigning for changes in the rules and practice of conventional international trade (FINE, 2001).

The aim of FINE is to enable these networks and their members to cooperate on: 1) the development of harmonized core standards and guidelines for fair trade; 2) harmonization, and increase in the quality and efficiency of fair trade monitoring systems; 3) advocacy and campaigning work, harmonization of their information and communication systems. Since April 2004 FINE has run a fair trade advocacy office in Brussels.

Its role is to coordinate the advocacy activities of fair trade proponents at both the European and the international levels. The aim of the office is to step up public support for fair trade and to speak out for trade justice. In 1997 Dutch, Belgian, Swiss, German, French, British and eleven other National Fairtrade Organizations (NFO) established Fairtrade International in Bonn, Germany. Fairtrade international is responsible for Fairtrade labelling at an international level, development and reviewing the Fairtrade Standards. In 2002, they launched, for the first time, an International Fairtrade Certification Mark (FAIRTRADE Mark), which is now a famous brand name. In 2009, Fairtrade International along with the World Fair Trade Organization (WFTO) - a global network of organizations representing the Fairtrade supply chain Fairtrade umbrella organization, originally called the International Federation for Alternative Trade established in 1989- adopted the Fairtrade Principles, which provides a single international reference point for Fairtrade.

There are five core principles as presented in Table 2. In addition, Fairtrade system improves the relative position of women and other disadvantaged groups and respects the rights of children (ILO Conventions Nos. 138&182).

Table 2. *Core principles of the Fairtrade*

<i>Market access for marginalized producers</i>	-Includes small producers in the markets- -Helps shorten trade chains-
<i>Sustainable and equitable trading relationships</i>	-Determination of prices by assessment of economic, social and environmental well-being- -A long-term trading partnership-
<i>Capacity building & empowerment</i>	-Assist producer organizations to develop knowledge, skills and resources-
<i>Consumer awareness raisin & advocacy</i>	-Informing consumers of the need for social justice- -Advocates and campaigners for wider reform of international trading rules-
<i>Fair Trade as a “social contract”</i>	-Buyers (and consumers) agree to do more than is expected by the conventional market (paying fair prices, providing pre-finance...)- -Producers use the benefits to improve their lives-

Source: *WFTO(2009)*

The main differences between Free trade and Fairtrade are presented in Table 3.

Table 3. *Key difference between Free trade and Fairtrade*

	Free trade	Fair trade
Main goal:	To increase nations' economic growth	To empower marginalized people and improve the quality of their lives
Focuses on:	Trade policies between countries	Commerce among individuals and businesses
Primarily benefits:	Multinational corporations, powerful business interests	Vulnerable farmers, artisans and workers in less industrialized countries
Critics say:	Punishing to marginalized people& the environment, sacrifices long-term	Interferes with free market, inefficient, too small scale for impact
Major actions:	Countries lower tariffs, quotas, labor and environmental standards	Businesses offer producers favorable financing, long-term relationships, fair prices and higher labor and environmental standards
Producer compensation determined by:	Market and government policies	Living wage and community improvement costs
Supply chain:	Includes many parties between producer and consume	Includes fewer parties, more direct trade
Key advocate organizations:	World Trade Organization, World Bank, IMF	Fairtrade International, WFTO

Source: *Fairtrade Federation (2007)*

Geographical scope of Fairtrade

FLOCERT is the independent certifier for Fairtrade which operates a transparent and globally consistent certification system following the requirements of ISO 17065. FLOCERT audits producers, traders and companies to ensure compliance with internationally-agreed Fairtrade Standards. The size of Fairtrade producer organizations varies from small cooperatives with a few farmer members to large plantations with hundreds of workers, on up to large second-grade cooperatives with thousands of farmer members.

Producer organizations can be Fairtrade certified just in certain countries. Fairtrade International considers income *per capita*, wealth disparity and other economic and social indicators, as well as long-term impact for

producers and Fairtrade International's ability to support producers, to determine which countries can be included in the geographical scope. Excluded from Fairtrade International's geographical scope are members of the European Union and G8-countries as well as countries with a firm accession date for entry into the EU.

This means it would be necessary to consider, before proposing including any European countries, whether they are likely to join the EU within the next 10 years or so.

At present, Fairtrade producer-countries are: 6 countries in Northern Africa, 25 in Western Africa, 11 in Eastern Africa, 16 in Southern Africa, 7 in Middle East, 3 in Western Asia, 5 in Central Asia, 3 in eastern Asia, 9 in Southern Asia, 9 in South-Eastern Asia, 18 in Pacific, 8 in Central America and Mexico, 11 in Caribbean and 12 in South America (Table 4) (FAIRTRADE, 2015).

In contrast to the producer rules - only poor small-scale farmers from certified producer-countries can produce and certify Fairtrade products from primary production, all countries can be processor-countries, i.e. (Fairtrade orange juice from Fairtrade oranges, Fairtrade chocolate from Fairtrade cocoa). Once produced, the Fairtrade products are sold to the Fairtrade certified traders.

Famous alternative trade organizations (ATOs) are Asha Handicrafts Association (India), Undugu Fair Trade Limited (Kenya), Level Ground Trading Ltd (North America and Pacific Rim), CIAP Intercrafts Peru SAC, Pachacuti, Oxfam and Traidcraft (Europe).

For example, Asha (hope in *sanskrit*) Handicrafts is a not-for-profit making body, based in Mumbai, working to promote Fair Trade and Fair Trade practices. As a member organization of the WFTO, Asha Handicrafts ensures that the benefits of handicraft production reach the craftspeople themselves.

Thousands of artisans and producer groups depend on Asha Handicrafts for assistance throughout India. By purchasing directly from the artisan groups and offering advance payments on orders, Asha increases the income levels of producer groups and prevents the accumulation of long-term debts and also provides training and teaching facilities, establishing new local groups of craftsmen.

Table 4. Fairtrade producing countries

Africa and the Middle East	Northern Africa	Algeria Egypt Libya Morocco Sudan Tunisia
	Middle East	Iraq Jordan Lebanon Oman Palestine Syria Yemen
	Western Africa	Benin Burkina Faso Cameroon Cape Verde Central African Republic Chad Congo Cote d'Ivoire Equatorial Guinea Gabon Gambia Ghana Guinea Guinea-Bissau Liberia Mali Mauritania Niger Nigeria Sao Tome and Principe Senegal Sierra Leone Togo
	Eastern Africa	Burundi Congo (DRC) Djibouti Eritrea Ethiopia Kenya Rwanda Somalia South Sudan Uganda Tanzania
	Southern Africa	Angola Botswana Comoros Lesotho Madagascar Malawi Mauritius Mozambique Namibia Seychelles South Africa Swaziland Zambia Zimbabwe
Asia and Pacific	Western Asia	Armenia Azerbaijan Georgia
	Central Asia	Kazakhstan Kyrgyzstan Tajikistan Turkmenistan Uzbekistan
	Eastern Asia	China* Korea (DPRK) Mongolia
	Southern Asia	Afghanistan Bangladesh Bhutan India Iran Maldives Nepal Pakistan Sri Lanka
	South-Eastern Asia	Cambodia Indonesia Laos Malaysia Myanmar Philippines Thailand Timor-Leste Viet Nam
	Pacific	Cook Islands Fiji Kiribati Marshall Islands Micronesia Nauru Niue Palau Papua New Guinea Samoa Solomon Islands Tokelau Tonga Tuvalu Vanuatu Wallis and Futuna Island
Latin America and the Caribbean	Central America and Mexico	Belize Costa Rica El Salvador Guatemala Honduras Mexico Nicaragua Panama
	Caribbean	Antigua and Barbuda Cuba Dominica Dominican Republic Grenada Haiti Jamaica Saint Kitts and Nevis Saint Lucia Saint Vincent and the Grenadines Trinidad and Tobago
	South America	Argentina Bolivia Brazil Chile Colombia Ecuador Guyana Paraguay Peru Suriname Uruguay Venezuela

* In China, producers can only be certified against the Standard for Small Producer Organizations. Contract Production and Hired Labour set-ups cannot be certified as Fairtrade in China.

Source: *Fairtrade International (2015)*

Minimum and premium price

Fairtrade system guarantees producers a minimum price and premium price (Table 5). Farmers, hired workers, artisans and other producers receive a fair price or wage for their time and materials. Producer organizations often receive pre-harvest or pre-production credit on favorable terms. Minimum price cover average costs of sustainable production. An additional sum of money, called the premium, goes into a communal fund for workers and farmers in order to improve their social, economic and environmental conditions. Farmers decide democratically by committee how to invest the premium.

The Fairtrade minimum price defines the lowest possible price that a buyer of Fairtrade products must pay the producer. The minimum price is set based on a consultative process with Fairtrade farmers, workers and traders and guarantees that producer groups receive a price which covers what it costs them to grow their crop. When the market price is higher than the Fairtrade minimum price, the trader must pay the market price.

Table 5. *Example of some actual minimum and premium prices*

Product	Price applied to	Currency/Unit	Minimum price	Premium price
Sugar, cane sugar (Cane sugar)-conventional	worldwide	USD/1 MT	Commercial price	80
Sugar, cane sugar (Cane sugar)-organic	worldwide	USD/ 1MT	Commercial price	60
Quinoa (Cereals)-organic processed	South America	USD/ 1MT	2.600	260 (of which at least 30% have to be invested in environmental sustainability)
Quinoa (Cereals)-conventional processed	South America	USD/ 1MT	2.250	260 (of which at least 30% have to be invested in environmental sustainability)
Bananas (Fresh Fruit)-organic	ACP countries	USD/18.4 kg	13.3	1
Bananas (Fresh Fruit)-conventional	ACP countries	USD/18.4 kg	7.75	1
Rice-conventional	Egypt	EUR/1 MT	125	15
Rice-organic	Egypt	EUR/1 MT	152	15
Cocoa, organic beans	worldwide	USD/1 MT	2300	200
Coffee Arabica-conventional, washed	worldwide	USD/1 pound	1.40	0.20 (of which at least 0.05 for productivity and/or quality)
Seed cotton-organic	South America	EUR/ 1 kg	0.59	0.05
Seed cotton-conventional	South America	EUR/1 kg	0.49	0.05

Source: FAIRTRADE (2016)

In 2012-2013 €95.2 million fair-trade premium delivered to producers, of which 6% spent on services to support young people, children and women. Small producer organization spent 37% of their premium on investments supporting productivity or quality improvement. For example, 7% of the Fairtrade Premium was used to supply or subsidize inputs such as fertilizers, seeds, plants, tools, or other equipment to their farmer members, all of which can enhance productivity and crop quality; 6% for training farmers or for helping them to implement good practices at farm level; 4% to supply credit and financing to farmers; 2% was used to provide services such as support for education and healthcare to cooperative members and their families etc. Workers on plantation spent 24% of their fair-trade premium on education. On plantation, direct support for workers and their families increased substantially to account for 65% of all Fairtrade Premium use. This was used to support education for workers and their children (providing bursaries, books, and uniforms), for workers and their families healthcare, for improvements in workers' housing, for loans and credit, for subsidized shops and child nursery facilities (FAIRTRADE, 2014).

Does Serbia need to build up Fairtrade system?

According to current Fairtrade standards, Serbian Fairtrade producers are not allowed to enter into system. The most serious research about possible integration of Fairtrade in Serbia (Brkovic, 2015) pointed out that the Serbian Fairtrade traders and consumers are just emerging, and the Serbian Fairtrade campaigners have not founded a national Fairtrade organization yet. The crucial step on the road to development will be the foundation of the Serbian National Fairtrade organization- "Fairtrade Serbia". Author concludes that there are calls for its development and rationales why it is important. Poor and marginalized small-scale producers are able to follow the rules and regulations in terms of quality, quantity and continuity if the sustainable partnership is guaranteed. There is a hope that the essential condition for Fairtrade- development of long-term trade relations- can be formed even it is not obligatory for big supermarkets because Delhaize Serbia has introduced Fairtrade products "before the existence of any 100% Serbian Fair Trade company and without any pressure from Serbian Fairtrade campaigners" (Brkovic, 2015). Also, author has shown some weaknesses of the current Fairtrade system and commented inability of Serbia to enter into system. Comparative analyses between Serbia and other upper-middle income

countries which are involved in the system had shown that the main reason for entering the system- producer-included countries are less developed than the ones who are excluded- was not complied with the fact that some included countries “scored higher than Serbia in every single category” (Table 6).

Table 6. *Comparative analyses Serbia vs. Mexico and Chile*

Category	Serbia (producer excluded) (1/144)	Mexico (producer-included) (1/144)	Chile (producer-included) (1/144)
Ethical behavior of firms	132	76	24
Cooperation in labor-employer relation	139	47	39
State of cluster development	133	35	27
Local supplier quantity	110	42	61
Local supplier quality	113	37	45
Affordability of financial services	100	66	21
Ease to access to loans	105	82	21
Buyer sophistication	138	50	28
Agriculture policy costs	119	123	14
Favoritisms in decisions of government officials	132	73	21
Burden of government regulation	136	97	32
Quality of overall infrastructure	120	65	31
Quality of roads	122	50	23
Quality of the educational system	111	100	91
Brain drain	141	54	14
Intensity of local competition	137	75	39
Extent of market dominance	142	113	112
Property rights	130	71	37
Efficiency of legal framework in settling disputes	138	100	23
Nature of competitive advantage	134	70	114

Source: *Brkovic (2015)*

The macroeconomic environment is also an indication of the difficulties in which the country finds itself. Economy of the Republic of Serbia in the last period is characterized by a decline in most macroeconomic indicators, primarily the decline in GDP, an increase in the unemployment rate, the trade deficit and public debt. The share of employment in the agriculture sector in the total number of employees

was 19.5% in 2015, while the share of GDP of the agricultural sector in total GDP was 9.7%. In the creation of Serbian GDP, agriculture accounts livestock is 30.5%, while in the developed countries this share reaches 60% (Muminovic, 2012). The average net wage in the agricultural sector compared to net income at the level of the entire the economy maintained a level of around 85%, i.e. the average net wage in the agriculture sector is about 15% lower than the average level of net income (Ministarstvo poljoprivrede, 2016).

Serbian milk production sector

In Serbia, there are on average 0.34 head of cattle per hectare of arable land, compared to the 2.2 cows per hectare of arable land in the EU (Muminovic, 2012). Based on the 2012 Census of Agriculture in Serbia there are 155.732 family farms with 409.753 dairy cows (RZS, 2012). The biggest share (87%) in the total number of family farms specialized for milk production were recorded in family farms with 1-9 livestock units (Table 7).

Table 7. *Number of family farms and dairy cows according to livestock units*

Total		0		1-9		10-19		≥20	
Dairy cows (No)	Family farm (No)	Dairy cows (No)	Family farm (No)	Dairy cows (No)	Family farm (No)	Dairy cows (No)	Family farm (No)	Dairy cows (No)	Family farm (No)
409753	155732	0	0	258177	135251	81991	15386	69585	5095

Source: RZS - Baza podataka

According to the same Census the economic size of dairy farms is very unfavorable in Serbia (Table 8). The economic size of farms is one of the criteria utilized to classify agricultural holdings according to the Community typology for agricultural holdings (Commission Regulation (EC) No 1242/2008 (867/2009) of 8 December 2008). The economic size of an agricultural holding is measured as the total Standard Output (SO) of the holding. The SO of the holding is calculated as the sum of the SO of each agricultural product present in the holding multiplied by the relevant number of hectares or heads of livestock of the holding. The SO coefficients are expressed in EUR and the economic size of the holding is measured as the total standard output of the holding expressed in EUR.

Table 8. Number of family farms and heads by economic farm size

Total	Dairy cows (No)	409753
	Family farm (No)	155732
Value EUR 0-2000	Dairy cows (No)	11753
	Family farm (No)	10911
Value EUR 2000-4000	Dairy cows (No)	55302
	Family farm (No)	39650
Value EUR 4000-8000	Dairy cows (No)	114959
	Family farm (No)	57254
Value EUR 8000-15000	Dairy cows (No)	104588
	Family farm (No)	31831
Value EUR 15000-25000	Dairy cows (No)	53049
	Family farm (No)	9910
Value EUR 25000-50000	Dairy cows (No)	39923
	Family farm (No)	4594
Value EUR 50000-100000	Dairy cows (No)	18094
	Family farm (No)	1259
Value EUR 100000-250000	Dairy cows (No)	9914
	Family farm (No)	294
Value EUR 250000-500000	Dairy cows (No)	1967
	Family farm (No)	27
Value EUR 500000-750000	Dairy cows (No)	170
	Family farm (No)	1
Value EUR 750000-1000000	Dairy cows (No)	34
	Family farm (No)	1
Value EUR 1000000-1500000	Dairy cows (No)	0
	Family farm (No)	0
Value EUR 1500000-3000000	Dairy cows (No)	0
	Family farm (No)	0
Value EUR 3000000-	Dairy cows (No)	0
	Family farm (No)	0

Source: RZS (2012)

The largest share in the total number of farms (37%) have farm which economic size is 4.000-8.000 EUR with an average of 2 cows. 20.4% of farms have economic size of EUR 8.000-15.000 (3.3 cows). Even 10.911 farms have economic size of just EUR 0-2.000 (1.08 cows), while 39.650 farms have value of EUR 2.000-4.000 (1.4 cows in average). This means that 69% of the total registered dairy family farms have economic size less than EUR 8.000.

As could be seen in Table 9 average number of dairy cows in family farms is only 2.6, more than 10 times lower than in the EU where in 2010, the average EU specialist dairying holding had around 28 dairy cows with considerable variations among the Member States: from 141

dairy cows per holding in Denmark to less than 15 cows in 7 member states (the most striking in Romania- 3 cows per specialist dairying farm) (Marquer, 2013).

Number of dairy cows in Serbia fell from 938.000 in the year 1989 to just 585.000 in 2009 (Muminovic, 2012). This a downward trend continues in the following years, number of dairy cows in Serbia was just 430.000 in 2015. About 25% of all agriculture holdings are involved in milk production. 108.774 farms or 70% of all farms engaged in the production of milk housing just 1.4 cows in average, 27.4% housing 3-9 cows, 2.1% have 10-19 cows, while larger farms with more than 20 cows account for just 0.5% in the total number of family dairy farm (Table 9).

Table 9. *Households by dairy herd size*

Total	Dairy cows (No)	409753
	Family farm (No)	628552
0	Dairy cows (No)	0
	Family farm (No)	472820
1-2	Dairy cows (No)	153870
	Family farm (No)	108774
3-9	Dairy cows (No)	182139
	Family farm (No)	42675
10-19	Dairy cows (No)	41616
	Family farm (No)	3312
20-29	Dairy cows (No)	13983
	Family farm (No)	606
30-49	Dairy cows (No)	8218
	Family farm (No)	232

Source: *RZS (2012)*

Contrary to the obvious difficult situation for small farmers, profitability analysis of big and medium-sized dairies indicates that the dairy industry in Serbia is a highly profitable independently of surrounding economic conditions. This can be described by the return on assets ratio in 2008 (9.70%), which even increased in 2009 (to 11.33%) despite the crisis (Muminovic, 2012). There is a reasonable suspicion that a large number of dairies in Serbia operate in grey economy since out of 200 registered dairies only 123 are active (Muminovic, 2012). Big dairies own 90% of the total capacity, medium sized 6%, whereas small dairy companies only have 4% of the total capacity (Vlada Republike Srbije, 2010). This practically means that Serbian dairy market leader is in the real monopoly position (Muminovic, 2012). The prices of milk buy-out in Serbia are the lowest in the whole region, and retail prices are the highest in the region

(Muminovic, 2012). A study has shown that retail prices of milk grew by 119% in the period of 2000-2012 (2004-2006=100), profit margins goes from 33% in 2000 to 152% in 2009 (Figure 1) (Lovre and Brankov, 2015).

Figure 1. *Milk prices in Republic of Serbia (2000-2012)*

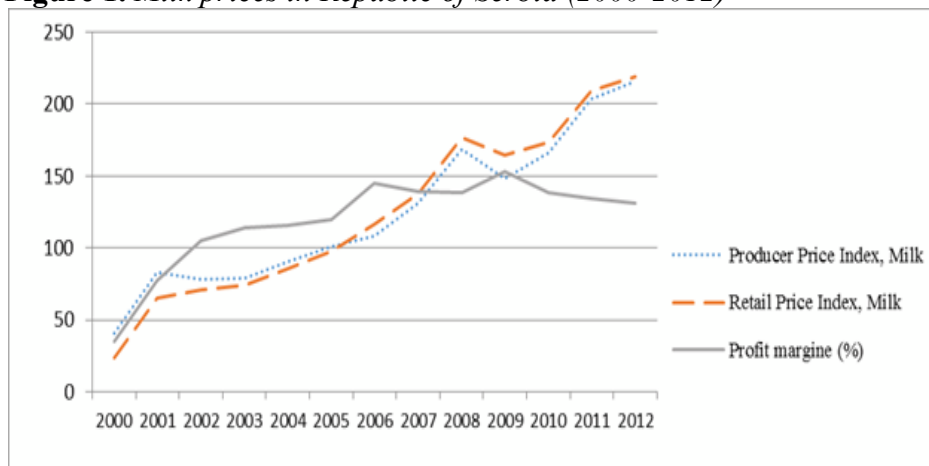

Source: *Lovre and Brankov (2015)*

Dairies purchase is another problematic point in the portrait of the Serbian milk production sector. Of the total quantity of cow's milk produced in 2015, was purchased around 837 million liters or 55.7% (Ministarstvo poljoprivrede, 2016) what significantly differ from the EU where 93% of annual milk production is bought by dairy industry (Muminovic, 2012). In addition, there are many unfair trade practices-“Although the dairies are obliged to submit the results of all analysis (fat content in the milk...) to farmers, they usually do not do it ...they are trying in many ways to reduce milk purchasing and to cancel contracts with farmers” stated M. Risticovic, the President of the Assembly Committee for Agriculture in a daily newspaper (Risticovic, 2016).

Finally, problematic situation in the milk sector in Serbia is best illustrated by consumption trends. According to the Survey on consumption of households conducted by the Serbian Statistical Office, the average consumption of fresh milk in Serbia during 1997-2014 declined from 90.6 to 47.4 liters *per capita* (Figure 2).

Figure 2. Average milk consumption in Serbia (1997-2014)

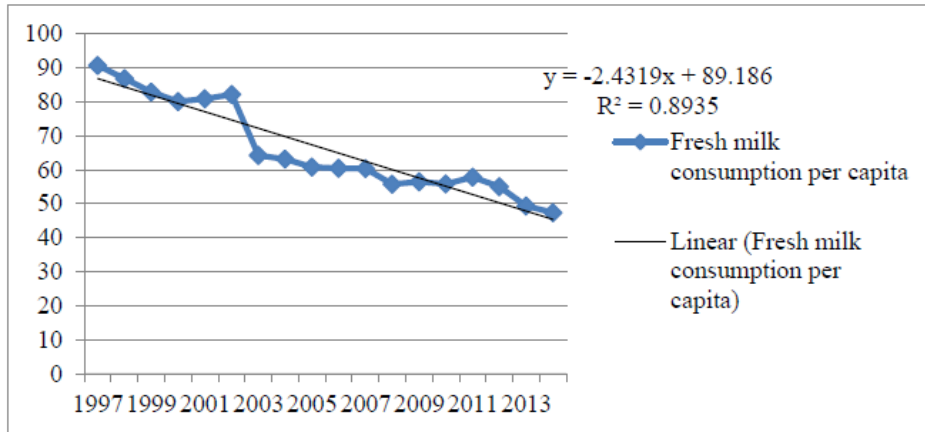

Source: Author's calculation based on Serbian Statistical Office data

Presented crisis clearly shows that the Serbian dairy sector has to be changed at all levels. Starting point can be small family dairy farms on the edge of a precipice, through the introduction of a Fairtrade milk scheme which will provide them with a guaranteed fair price. It should be relatively simple to come up with a minimum price based on existing research on the cost of production and linking this to any agreed ethical, welfare and environmental criteria (Brankov and Lovre, 2016).

Discussion and conclusions

Fairtrade is an alternative approach to conventional trade based on a partnership between producers and consumers. System improves the lives of small farmers and offers consumers a powerful way to reduce poverty through their everyday shopping. There are now more than 1.5 million small-scale farmers and plantation workers who belong to Fairtrade certified producer organizations which number has grown from 827 (2009) to 1210 (end 2013). Unfortunately, according to current rules Serbian Fairtrade producers are not allowed to enter into Fairtrade system. But, this is not an obstacle for the introduction of national fair trade label. Starting point can be small family dairy farms on the edge of a precipice, which should receive fair price for their products. If we don't do something like this the small dairy family farms will disappear simply to be replaced by ever-larger industrialized farms. The negative consequences of this are not measurable. In that sense all activities on the promotion of Fairtrade in Serbia should be most welcomed.

Currently, promotion of the Fairtrade concept in Serbia is in the initial phase, for media practically imperceptible. There is only one web site-facebook Fairtrade-Serbia which mission is raising awareness of consumers about Fairtrade products and initiates the establishment of national Fairtrade organizations. This web page informs the consumers about Fairtrade products that can be bought in Serbia (tea, chocolate cream, ice cream, pineapple, cosmetics etc). So far organizations involved in the fight against human trafficking, promote Fairtrade products that have not been incurred slave labor, so the NGO Atina first in Serbia organized Fairtrade tea party, the first in the region and they served pancakes with Fairtrade ingredients (chocolate cream, jam and ice cream). Humanitarian Centre from Novi Sad has promoted Fairtrade products at the festival EXIT, also the Balkan Centre for Development Studies has contributed to the promotions. To increase the impact, potential involvement of Serbian Orthodox Church in the Fairtrade would be very significant. Involvement of the church in this kind of commercial activity is not a novelty. Several NGO and church-driven project began in 1988 to help smallholders coffee farmers. The initiative was started by Nico Rozen from Solidaridad, a Dutch ATO and Frans van der Hoff, a priest living in Mexico. Famous label Max Havelaar (fictive figure of Max Havelaar who opposed the exploitation of workers on plantations), for coffee coming from Mexico has been created. "Labeling moved socially minded consumers out of church halls and basements and into supermarkets and other retail centers. The label provided a signal of the direct connections to producers that in the past were provided by word of mouth in church and solidarity groups" (Free, 2010).

Literature

1. Brankov, T., Lovre, K. (2016): *Fair trade like cooperatives in Serbia-near or distant future?* Safe food. XX International Eco-conference 2016, Ecological Movement, Novi Sad, 28th-30th September, pp. 233-241.
2. Brkovic, F. (2015): *An Assessment of Possibilities for Stronger Inclusion of Upper-middle-income Economies in the Fairtrade System-Case Study Serbia*. Doctoral dissertation, Université libre de Bruxelles.

3. FAIRTRADE (2014): *The scope and benefits of fair-trade*. Sixth edition
2014.http://www.fairtrade.net/fileadmin/user_upload/content/2009/resources/2014-Fairtrade-Monitoring-Scope-Benefits-final-web.pdf
(September 15, 2016).
4. FAIRTRADE International (2015): *Fairtrade Geographical Scope Policy of Producer Certification*.
http://www.fairtrade.net/fileadmin/user_upload/content/2009/standards/documents/Geographical_Scope_Policy_EN.pdf (September 1, 2016).
6. FAIRTRADE (2016): *Minimum Price and Premium Information*.
<http://www.fairtrade.net/standards/price-and-premium-info.html>
(August 15, 2016).
7. Fairtrade Federation (2007): *Key difference between Free trade and Fairtrade*. <http://www.fairtraderesource.org/uploads/2007/09/Free-Trade-Is-Not-Fair-Trade.pdf> (September 3, 2016).
8. FINE (2001): *Definition of fair trade*. <http://wfto.com/fair-trade/definition-fair-trade> (September 30, 2016).
9. Free, R.C. (Ed.) (2010): *21st century economics: A reference handbook*. SAGE Publications. pp.507.
10. Fridell, G. (2004): *The fair trade network in historical perspective*. Canadian Journal of Development Studies/ Revue canadienne d'études du développement, 25(3), 411-428.
11. Fridell, G. (2007): *Fair trade coffee: The prospects and pitfalls of market-driven social justice* (Vol. 28). University of Toronto Press.
12. Lovre, K., Brankov, T. P. (2015): *The Supermarket Revolution in the Balkan Countries: The Case of Serbia*. *Agroeconomia Croatica*, 5(1):1-10.
13. Marquer, P. (2013): *Portrait of the EU milk production sector*. http://ec.europa.eu/eurostat/statistics-explained/index.php/Archive:Milk_and_dairy_production_statistics
(October 1, 2016).

14. Ministarstvo poljoprivrede (2016): *Izveštaj o stanju u poljoprivredi u 2015. godini*, Beograd.
15. Muminović, S., Pavlović, V. (2012): *Profitability of dairy industry in Slovenia, Croatia and Serbia*. *Mljekarstvo*, 62(2): 96-110.
16. Risticovic, M. (2016): *Farmeri masovno napustaju proizvodnju mleka*. http://www.danas.rs/danasrs/ekonomija/farmeri_masovno_napustaju_proizvodnju_mleka.4.html?news_id=302246 (October 1, 2016).
17. RZS (2012). *Popis poljoprivrede 2012. Poljoprivreda u Republici Srbiji*. <http://pod2.stat.gov.rs/ObjavljenePublikacije/Popis2012/PP-knjiga1.pdf> (September 10, 2016).
18. Serbian Statistical Office (1997-2014): *Survey on consumption of households- Annual reports*.
19. Skidelsky, R. (2005): *Keynes, globalisation and the Bretton Woods institutions in the light of changing ideas about markets*. *World Economics*, 6(1): 15-30.
20. Varangis, P., Larson, D.F. (1996): *Dealing with commodity price uncertainty*. World Bank Policy Research Working Paper, (1667).
21. Vlada Republike Srbije (2010): *Nacionalni program za poljoprivredu od 2010. do 2013. godine*, Službeni glasnik Republike Srbije br. 83/10 od 09. novembra 2010. godine.
22. WHTO (2009): *A chapter of the fair-trade principles*. http://fairtrade-advocacy.org/images/Charter_of_Fair_Trade_principles_EN_v1.2.pdf (August 10, 2016).

DEVELOPMENT OF COMMODITY EXCHANGES IN FUNCTION OF AGRIBUSINESS IN SERBIA

Vlado Kovačević¹, Zorica Vasiljević²

Abstract

This paper aims to determine the impact which developed commodity exchanges have to the improvement of agricultural products' market in Serbia. There are two types of commodity-exchange markets; first, spot or daily trading which provides to participants in trading the purchase of agricultural products by transparent prices with safe delivery. Delivery of agricultural products on spot commodity-exchange is mostly done within several days. The second type of commodity-exchange operations is the commodity derivative market, where buying and selling of agricultural products is realized in a precise in the future. Spot market which operates within the only stock market in the Republic of Serbia-Produktna berza a.d. Novi Sad is poorly developed. Commodity derivative market has not been established in Serbia. According to the analyses done within this work, the underdeveloped commodity-exchange operations are the consequences of, first of all, inadequate legal framework, as well as the non-established preconditions in form of a common business environment, significant for operating of commodity exchanges. Development of commodity exchanges would contribute significantly to the improvement of agricultural products market, as well as the possibility to manage the risk in farmers' business.

Key words: *Commodity exchange, spot market, futures, options, commodity derivatives*

¹ Vlado Kovačević Ph.D., Minister Advisor, Ministry of Agriculture and Environmental Protection, Nemanjina Street no. 22-26, 11000 Belgrade, Serbia, Phone: +381 64 65 81 519, E-mail: vlado.kovacevic@minpolj.gov.rs.

² Zorica Vasiljević Ph.D, Full Professor, University of Belgrade - Faculty of Agriculture, Nemanjina Street no. 6, 11080 Belgrade-Zemun, Serbia, Phone: +381 641439942, E-mail: vazor@agrif.bg.ac.rs.

Introduction

One of the basic characteristics of contemporary business operations is dynamics and the increase of uncertainty degree in business operations. Cash flow of an enterprise is constantly exposed to the changes in prices of products and inputs, tax and interest rates, labour costs, exchange rates, unfavourable effects of natural factors, etc. As a consequence of such manifestations it has occurred the need for the development of financial instruments, by which application it would make the business operations more certain. For that reason, in the past four decades has come to the powerful development of derivative markets, which provide to economic entities in developed market economies the use of different hedging strategies. In that way, hedgers can transfer the risk of change in assets prices to which they were created the derivative securities to speculators, who expect to make a profit by accepting the risk (Zakić & Kovačević, 2012).

On derivative exchanges is traded with derivative securities. Value of derivative securities is derived from a value of other assets and this how terms “derivative securities” and “derivatives” originated. The derivative securities were created to numerous forms of assets, such as: metals, energy substances, agricultural products, shares, interest rates, foreign currencies, indices, time indicators, etc. These securities are named also futures contracts, in regard that the realization of trading by these contracts will happen in future (Chisholm, 2010).

At the core of derivative securities there are some other forms of basic assets: commodity, foreign currencies, interest rates, other securities, time indicators or indices. Term “*future trading*” is related to derivatives and it has series of characteristics which differs it from the prompt (*spot, casa*) trading. Unlike the prompt business operations, where a transaction ends immediately or no later than 2-5 days, a future (forward) character of conducting transactions implies the existence of a certain period of execution. There is a difference also in regard to the physical delivery of assets underlying a future contract in sense of a fact that, in prompt businesses a cycle of trade compulsorily ends with the delivery of commodity, while futures operations is not obligatorily followed by the delivery of assets, but this contract can be performed also with financial conciliation.

Economic environment in Serbia has been developed for many years within this economic system in which there have been many elements of planned agriculture. After transition toward the predominantly market way of doing business in 1990ies, the agricultural enterprises were facing business risks, uncharacteristic to business in planned economy. In other words, these mentioned risks in business were uncharacteristic to a high vertically integrated and planned organized economic sector in Serbia as it was in past decades.

Establishing a commodity derivative market represents one of the mechanisms which provide the management of risk in economic entities. In order to make the mentioned system work, it is necessary to set up basic preconditions, like: 1) sufficient quantities of uniform quality commodity (in case of commodity derivatives), 2) regulated optimal quality standards by which would trade on the stock exchange, 3) macro-economic stability, 4) legal framework which ensures the establishment of all commodity exchange institutes, 5) liberalized market, etc.

According to a review of experience in the development of futures contracts market in the world, as well as the analysis of needs and status of commodity-exchange operations in Serbia, there were given recommendations for further activities which would lead towards the establishment of a contemporary commodity exchange and would provide to agricultural enterprises in Serbia to use all mechanisms of business risk control, which were available to agricultural enterprises in developed countries.

Beside direct benefits which come from a possibility to use commodity-exchange instruments in daily business, the derivative market would have a positive direct impact to the economy in Serbia through the effects for the total business environment which manifest primarily through impact to the decrease in price fluctuations of agricultural products and inputs, interests, macro-economic stability, price transparency, etc. (Zakić & Kovačević, 2012).

In the front of Serbia it is an extensive work in setting up a legal regulatory rules related to the regulation of commodity-exchange operations, changes of various state policies which affect the commodity-exchange operations, as well as the education of participants in a commodity exchange system on possibilities to apply a hedging strategy by using derivative exchanges instruments (Zakić & Vasiljević, 2013).

Importance of commodity exchanges for agribusiness sector

There are two types of commodity-exchange markets:

- Spot and
- Commodity derivative markets.

On the spot market, buying and selling of commodity is realized after which the commodity delivers physically, as a rule within five days. The commodity from the group of agricultural products, the most trade with, on the commodity exchange is: wheat, maize, soybean, sunflower, soybean oil meal, fertilizer, etc.

A basic precondition in order to trade with one product on the exchange, is that it can be standardized, i.e. that a buyer, in accordance to a description of product on an exchange table, can buy this product without having insight in the product.

It is necessary to emphasize that the volume of spot trading on developed commodity exchanges reduces each year, so most of developed commodity exchanges don't have spot trading but only derivative. The reason for disappearance of spot trading is in the development of electro-communication technologies and therefore supply and demand for agricultural products meet easily outside the exchange and isn't exposed to the exchange commission costs. In spot commodity exchange trading, it is inevitable to pay, besides the exchange commission, also for transport of commodity to a standardized location of exchange delivery³. This fact burdens additionally the costs of exchange trading compared to out of exchange market trading, as the consequence of additional spot exchange costs. On developed commodity spot exchanges trade occurs for products which have low transport costs per u product unit.

On futures-commodity exchanges there are traded with standardized futures contracts:

- Future contracts and
- Option contracts.

In last decade, the USA market domination by derivative financial instruments gets weaker in regard to the Asian market.

³ In practice, the commodity has not been transported, but there are reduces by tables the price of commodity to standardized delivery place, usually the stock exchange airport.

Futures contracts are highly standardized contracts on selling and buying certain assets in the future. They have numerous similarities, but also differences in regard to the forward contracts.

Thanks to a high standardization, it is possible the secondary trading with futures contracts, unlike forward contracts. Another difference between futures and forwards is that the physical delivery of goods happens in about 2% of cases and most of futures end with a financial transaction. Unlike forward, they have high security that the contractual obligations will be executed, which realizes through a mechanism of the compulsory depositing of a “margin” deposit, both for buyer and seller.

For functioning of futures, a clearing house is necessary and it is appointed toward a futures buyer as a seller, and toward a seller as a buyer. The clearing house guarantees also for execution of duties from futures contracts. In this way, a direct acquaintance between buyers and sellers is not necessary, i.e. a personal trust turns to the institutional one. Hence, they trade with futures exclusively on organized market.

Option contracts can define as derivative securities, with a particular right. Relations among the contract parties are regulated by an *option contract*. Option agreement in legal terms represents incomplete contract, regarding that it entitles one party to buy or sell certain kind of commodity after a prior agreed price, but it doesn't oblige. The reason for the compliance of an option seller to a buyer's desire is that a writer, while making an option agreement, gets a premium or an option price.

Importance of commodity exchange for agribusiness sector in Serbia

Trading (trading) on spot commodity exchange market provides to the agricultural enterprises the following:

- To sell an agricultural product or buy the agricultural instrumental goods after transparent prices,
- Efficient buying and selling of commodity in short-term,
- Buying and selling commodity along with a decreased risk that commodity won't be paid, i.e. that the bought instrumental goods won't be delivered.

Hedging strategies with futures contracts are based on purchasing (opening hedging long position) or sale (opening hedging short position)

the futures contracts. In this way, the agricultural enterprises ensure a price of its agricultural product which is the most often still in the field in the moment of trading (trading) (Kolb & Overdahl, 2007). If the price at spot market at the futures maturity is lower than the contracted price on futures, a planned price will be compensated with futures gain and *vice versa*, if it is higher, it will be reduced for loss on futures. In that way, in both cases the price arranged on futures is realized.

Example: If it is assumed that the price on the derivative market was in December 12.5 RSD/kg for maize and this is the price which was satisfying farmers. For that reason, he/she contacts his/her broker and orders futures sale of 10,000 tons of maize for delivery in December, after the price of 12.5 RSD/kg. The futures contract closes in December after the price of 12.0 RSD/kg, and a manufacturer really sells maize on the spot market in November for 12 RSD/kg.

Table 1. *Striking short hedging position (no changes of basis)*

Corn spot price	Corn future price	Basis	
Planned price 12.5 RSD/kg	Opens a short position for November (sell) by 12.5 RSD/kg	/	
November – price on spot market 12 RSD/kg	Closing the position in November contract by price of 12 RSD/kg	/	
Result on spot market: 12.5-12 RSD/kg = 0.5 din/kg less than the planned price	Result on derivative market: 12.5-12 RSD/kg = 0.5 din/kg profit	/	Final score - Desired price 12.5 RSD/kg - Realized price on spot market 12 RSD/kg - Profit on derivative market 0.5 RSD/kg Total realized price 12.5 RSD/kg

Source: Authors' calculation

The essence of opening the short hedging position is in a fact that, if there comes to the decrease of prices on spot market as it is case in this mentioned example, the planned price (12.5 RSD/kg) is protected by a gain on a futures contract. It can be presented simpler that, if a manufacturer loses with the decrease of price from April to November on the spot market, then he will gain the same on the other side with the

decrease of prices on the derivative market. Mechanism of using the farmers hedging strategy, with the use of option contract, is shown in next example.

Example: Enterprise which deals with livestock production expects the increase in maize price and it has a dilemma whether to buy maize in July and to store it until May when it will be needed. The other solution would be to try to ensure a more favourable price through the purchase of *call* option on maize. For that reason, the agricultural enterprise purchases the *call* option with maturity in May next year and a determined strike price of 300 USD/t of maize, pays a premium of 30 USD/t for a contract of 1000 tons. Depending on trends of maize prices, the following possible situations are described in Table 2.

Table 2. *Strategy of purchasing call option - possible outcomes*

Price of maize on spot USD/t	Real value of options of USD/t	Profit/loss USD/t	Total profit/loss USD/t
272	0	-30	-3,000
296	0	-30	-3,000
300	0	-30	-3,000
305	5	-25	-2,500
330	30	0	0
348	48	18	1,800

Source: *Authors' calculation*

Turning point in the price of maize of 330 USD/t is shown in Table 2. Furthermore, the gain of an option buyer increases parallel to the increase in maize price. However, an option buyer, in range of maize price from 300 to 330 USD/t, will use their right to decrease a loss on premiums. Activating the option when the price of maize is under 300 USD have no sense, because it would produce extra-loss.

Development of the commodity exchanges in Serbia

Despite high fluctuations of prices of agricultural products in last few years and expressed need for the establishment of standardized forward marketing, the establishment never came to life in Serbia. The reason is primarily in the lack of legal regulatory rules which would create the possibility for forming basic institutions on the commodity exchange. Law on Capital Market anticipates the possibilities for the establishment of forward marketing, but not the possibility for the establishment of

clearing and balancing within the same exchange or an independent clearing house. Although it was announced passing of the Law on Public Procurement in weeks to come, right after the Law on Capital Market was passed in 2002, this was never happened, not even after ten and more years. Impossibility to form basic mechanisms of developed commodity exchange in Serbia has caused that today it is traded with simple instruments: commodity, warehouse receipts and poorly secured forwards, i.e. the instruments which require a lower level of commodity-exchange infrastructure.

Legal framework for functioning of the spot and futures commodity exchanges is different.

The spot commodity exchange operations are not regulated by the common Euro regulative and it is left to each EU member to regulate this field individually. In the past ten years, there were more attempts to arrange the field of commodity-exchange operations by the special Law on Commodity Reserves within the ministry authorized for trading operations. The current state in the field of spot commodity-exchange operations which realizes on the *Produktna berza a.d. Novi Sad* is a low level of “services” for participants in trading. This reflects first of all in:

- Absence of clearing services in a way that the participants in trading, after matching the exchange indents, get an interchangeable data and take care by themselves on disbursement, i.e. delivery of commodity;
- Non-established system of the exchange's arbitration, and therefore in case of dispute, the participants in trading in the process of commodity delivery are left to the long-lasting regular judicial procedures instead of fast out of court settlement at the exchange.

With a new legal framework which would regulate especially the spot commodity-exchange operations, it is possible to establish the exchange arbitration⁴, as well as security funds, which would provide better safety in execution of exchange trade. Additional safety and raising a level of services provided to the participants by the exchange would be in providing clearing on the spot commodity exchange, while a clearing house would take care on sellers' disbursement delivery.

⁴ There is a possibility for the enforcement of arbitration on commodity exchanges within the Law on Arbitration, but this arbitration system is not completely adequate for commodity exchange operations.

It is important to say that spot commodity-exchange operations in countries with high developed commodity-exchange operations loss its significance every year primarily due to the development of information and telecommunication systems, which make easier finding buyers and sellers outside the exchange. This fact one must have on mind while establishing the above mentioned institutes on the commodity exchange, because besides a positive effect on the increase of safety and the commodity exchange services they have a negative influence on the increase of trading costs, i.e. the exchange commission for the participants on spot commodity exchange.

For the establishment of futures commodity-exchange trading, there is important the fact that the Republic of Serbia, in the process of EU accession, is obliged to adjust its legislation in the field of futures contract market with the EU legislation.

In 2012, the law known as *EMIR*⁵ came into force and it was passed the similar clauses as *Dodd-Frank Act*. Basic clauses of EMIR, which refer to the commodity-exchange operations are: 1) compulsory clearing both for the exchange trading instruments and most of off-market trading instruments, 2) application of certain techniques of risk management for trading instruments which don't succumb to clearing, 3) reporting on trading⁶, 4) special requirements for the foundation and work of clearing houses and trading platforms (Kovačević, 2014).

On several occasions has been tried to establish the commodity-exchange operations in the Republic of Serbia, by regulating this field through passing a special Law on Commodity Exchanges. The legal possibility to do so existed in the past, until the change of MIFID 2 Directive, which was adopted on July 2014 and there was expected to come into force in January 2018. That is to say, this directive has classified commodity derivatives with financial and exotic derivatives into the unique category of financial instruments, by which the market and trading of all futures contracts was regulated in the same way. Taking into consideration this new approach to the directive, there follows that the regulation of all

⁵ See more: Regulation (EU) no. 648/2012 of the European Parliament and of the Council of 4th July 2012 on OTC derivatives, central counterparties and trade repositories.

⁶ Both parties in trading (dealing) are obliged to report dealing in a specific term.

futures contracts in Serbia should be done through the improvement of Capital Market Act (CMA). Exactly the establishment of commodity-exchange futures trading is of the great importance and significance for agro-business sector in Serbia and it is a subject of the common EU regulatory rules and the Republic of Serbia is obliged to adjust its regulatory rules with the common EU regulations.

There are legal preconditions for operating of futures commodity exchanges in the Republic of Serbia within the Capital Market Act. Besides, the derivative market, neither commodity, not financial, has begun to live. The reasons can be found primarily in inadequacy of the Capital Market Act, which is not harmonized with the common EU regulatory rules. Basic deficiencies of CMA are in a fact that there is no system of licensing and control of clearing houses, but a clearing function can be performed only by Central Register of Securities. This situation is not practice in regard that clearing is a form of “market services” and granting a monopoly to one institution is not possible. Secondly, the Central Depository of Securities cannot provide clearing services regarding that a basic function of this institution is keeping records on dematerialized securities. Taking over the clearing service, which implies taking over the risk from the non-fulfilment of contractual obligations of participants in futures trading would jeopardize due to bankruptcy of the Central Registry of Securities.

After the world economic crisis, there has come to the adjustment of legislative framework globally. G-20 Summit in St. Petersburg, held on 5th-6th September 2013 is of special importance. At the Summit it was given direction of development of commodity and financial organized market for 20 most developed countries, which have adopted principles for the development of derivative financial instruments trading⁷:

- Establishment of common criteria for functioning of the exchange and off-market organized markets,
- Regulation of trading with swaps⁸, through swap dealers licensing, registration of trading and clearing obligations for swaps trading,
- Strict obligation to report on trading,

⁷ See more: G 20 Leaders' Declaration, www.g20.org/documents/pittsburgh_summit_leaders_statement_250909.pdf (available: 15th October 2013).

⁸ Parties in contract give consent for the exchange of certain assets in future time by swaps. This kind of contract is characteristic also for dealing in currencies.

- Introduction of general criteria, common for regulatory authorities of commodity-exchange systems, as well as better coordination of the regulatory authorities' cooperation.

*The European Securities and Markets Authority (ESMA)*⁹ does a legislative and control function in the field of licensing and control of capital market. The commodity-exchange spot commodity market is not a subject of EU legislation arrangement, but it is left to every member-country to arrange.

It can be concluded that the establishment of derivative market is preconditioned with two factors: first, the regulation of foundation and work of clearing houses activities and second, the regulation of swap contracts.

Integration of the commodity and capital market exchanges within one exchange is of special significance, which is practice in contemporary developed exchanges (Belozertsov et al., 2012).

Besides the quality legal framework for functioning the spot and futures exchanges, of special importance is also setting up a stimulating general business environment that affects the commodity exchanges activities and this primarily relates to:

- The activities of the Republic Directorate for Commodity Reserves which must move from purchase where an intervention price is determined by the conclusion of Republic of Serbia to purchase through public offering collection. In the first model, a price determined administratively can be known to a small circle of tradesmen, which can lead to manipulations on the market;
- Providing sufficient amounts of commodity securities by which guarantee delivery.

The comparative analysis of the exchange trading on the most important commodity exchanges in the world and in Serbia was described in Table 3.

⁹ See more: European Securities and Markets Authority, www.esma.europa.eu (available: 11th July 2013).

Table 3. Comparative analysis of commodity-exchange systems in Serbia and in the world

Commodity exchange	Country	Commodity exchanges licensing and controlling system	Trade instruments	Clearing at comm. exch.	Arbitration	Trade platform	Warehouse receipts *	Exchange information system **
CME	SAD	Yes	Futures, options, indexes, spot	Yes	Yes	Electronic	Well developed	Well developed
CBOT	USA	Yes	Futures, options, indexes, spot	Yes	Yes	Electronic	Well developed	Well developed
MGEX	USA	Yes	Futures, options, indexes	Yes	Yes	Electronic	Well developed	Well developed
BMF	Brazil	Yes	Futures, options, indexes	Yes	Yes	Electronic	Medium developed	Well developed
NYX	EU	Yes	Futures, options, indexes	Yes	Yes	Electronic	Well developed	Well developed
BSE	Hungary	Yes	Spot, futures	Yes	Yes	Electronic	Well developed	Well developed
WGT	Poland	Yes	Spot, options	Yes	Yes	Electronic	Medium developed	Medium developed
RCE/BRM	Romania	Yes	Spot, futures	Yes	Yes	Electronic	Medium developed	Less developed
IME	Turkey	Yes	Spot	Yes	No	Electronic	Not established	Less developed
RTS	Russia	Yes	Futures	Yes	Yes	Electronic	Not established	Less developed
(NAMEX)	Russia	Yes	Spot, futures	Yes	Yes	Electronic	Not established	Less developed
Kiev-Agro-industrial Exchange – Kievagroprombirzha	Ukraine	Yes	Spot	No	No	Classic trade board	Not established	Less developed

BUCE	Ukraine	No	Spot	No	No	No	Classic trade board	Not established	Less developed
KICE	Kazakhstan	No	Spot	No	No	Less developed	Classic trade board	Less developed	Less developed
MCX	India	Yes	Futures, options, indexes, spot	Yes	Yes	Medium developed	Electronic	Medium developed	Well developed
NCDEX	India	Yes	Futures, options, spot	Yes	Yes	Medium developed	Electronic	Medium developed	Well developed
KEX	Japan	Yes	Futures	Yes	Yes	Not established	Electronic	Not established	Well developed
ECX	Ethiopia	Yes	Spot, forwards	Yes	Yes	Medium developed	Electronic	Medium developed	Medium developed
DCE	China	Yes	Futures, spot	Yes	Yes	Medium developed	Electronic	Medium developed	Well developed
ZCE	China	Yes	Futures, options, spot	Yes	Yes	Medium developed	Electronic	Medium developed	Well developed
SHFE	China	Yes	Futures, options, spot	Yes	Yes	Medium developed	Electronic	Medium developed	Well developed
ASX	Austral.	Yes	Futures, options	Yes	Yes	Well developed	Electronic	Well developed	Well developed
Produktma berza N.S.	Serbia	No	Spot, forwards	No	No	Well developed	Classic trade board	Well developed	Well developed

Source: Kovačević, 2014

* System of warehouse receipts is classified by the authors' evaluation, on: 1) less developed, 2) medium developed, and 3) well developed. Criteria for assessment are: 1) the existence of a system of licencing public warehouses, 2) the existence of a system of public warehouses operations control, 3) the existence of a system of voluntary remuneration, as well as terms for discharge of damages for a warehouse receipt owner, 4) whether the warehouse receipt is in paper or electronic form, and 5) the existence and types of public warehouses guarantees, first of all if the Compensation Fund is responsible for discharge of an eventual damage to warehouse receipts owners.

General globalization in commodity-exchange trading (trading), the regulation of commodity exchange operations, money flows etc., causes the need to be harmonized the business operations of Serbian commodity exchanges with the world commodity exchange systems. Experiences of successful commodity exchanges in the world could be helpful in setting up a Serbian commodity exchange model.

It can be concluded that there is a high connectivity between the development of commodity exchange system and trading volume on the commodity exchange, by analysing data from *Table 1*. The commodity exchanges which offer a “higher level” of services to clients, such as clearing, out of court protection and electronic trade platform have, as a rule, a higher trading volume. Positive influence on trading volume is also noticeable in case when the state institutions license and control the commodity exchange, which furthermore increases the safety.

In addition, there was recorded a positive impact of the development of warehouse receipts system, which provide safe delivery of commodity after matching of orders, to the development of commodity-stock exchange operations.

Produktna berza Novi Sad in regard to other world exchanges belongs to the group of exchanges with less developed exchange system. The reason is that this exchange does not fall under the system of licensing and control, it doesn't offer clearing and balancing services to its clients, but the participants in trading (trading) themselves take care on delivery and disbursement. Likewise, there is no provided extra-judicial protection, so the participants in exchange trading in case of dispute are left to the regular court procedure. There also lacks an efficient electronic system of trading (trading).

On the other hand, by the efforts of employees on *Produktna berza Novi Sad*, an efficient information system was established, used by many agricultural enterprises. A fact that Serbian commodity exchange could have a status of the regional commodity exchange is of great importance, in regard to a high correlation between the spot prices of maize and wheat in the region (Kovačević, 2014). It would be more favourable place for the implementation of hedging strategies of tradesmen from the region in the world exchange relations, where the risk in basis change is more expressed.

Conclusion

High developed commodity exchange trading had also the expressed positive impact to the agro-business sector operations' in Serbia.

Further development of trading with agricultural products through the legal regulatory rules within the ministry authorized for trading activities would have a limited impact in regard that the spot trading with agricultural products loses its significance due to the development of telecommunication systems and easier linkage between supply and demand out of the exchange.

The field of spot commodity exchange trading is not a subject of general and common EU regulations, and therefore Serbia can adjust the legal regulatory rules to its conditions. It is necessary to be careful because beside the positive impacts, which would be realized by an introduction of arbitration, clearing, protection funds, the introduction of these institutes also could have a negative impact through the increase in trading costs.

High price volatility of agricultural products in Serbia causes the need for the development of commodity derivative trading which provides to the farmers to apply the hedging strategies in order to insure prices in future time. For introduction and development of commodity futures' exchange, it is necessary to adjust the Law on Capital Market with the EU regulations, primarily in the field of licensing regulation and control of clearing houses work and reporting of trading with swap contracts.

According to the conducted research, it can be concluded that in one commodity exchange in Serbia it is dominant the trading with simple spot commodity exchange instruments. Furthermore, unlike the most of developed commodity exchanges, there is no connection with capital market exchanges. In accordance with done analyses, it is necessary to improve: a general business environment.

Commodity exchanges in Serbia could become the regional centres of commodity-stock exchange operations by fulfilling the above mentioned preconditions.

Literature

1. Belozertsov A. et al. (2012): Commodity exchange in Europe and Central Asia: A means of management of price risk, Working paper No. 5, FAO/World Bank, Rome, 2011., www.eastagri.org/publications/pub_docs/Europe%20and%20Central%20Asia_web2.pdf (22nd April 2013).
2. Dodd-Frank Wall Street Reform and Consumer Protection Act (Pub. L. 111-203, H.R. 4173).
3. G 20 Leaders' Declaration, www.g20.org/documents/pittsburgh_summit_leaders_statement_250909.pdf (15th October 2013).
4. Kolb R. and Overdahl J. (2007): Futures, Options, and Swaps / Edition 5, Blackwell Publishing, ISBN: 1405150491 ISBN-13.
5. Kovačević V. (2014): Development of commodity exchanges in the function of the management of business risk of agricultural enterprises in Serbia, Doctoral thesis, Faculty of agriculture Belgrade, University of Belgrade.
6. Milovanović D., Protić D. i Kovačević V. (2013): Potreba za dogradnjom pravnog sistema u vezi sa trgovinom standardizovanim robama i standardizovanim terminskim ugovorima, Pravo i privreda, br. 4-6, ISSN 0354-3501, pp. 289-308.
7. Law on capital market (Official gazette of the RS no. 31/2011).
8. Law on commodity reserves (Official gazette of the RS no. 18/92).
9. MFIR Regulation (EU) No 600/2014.
10. MiFID II Directive (Directive 2014/65/EU).
11. Zakić V. and Kovačević V. (2012): Importance of commodity derivatives for Serbian agricultural enterprises risk management, Proceedings, International Scientific Meeting - Sustainable agriculture and rural development in terms of the republic of Serbia strategic goals realization within the Danube region, Tara 6-8 December 2012, Institute of Agricultural Economics, Belgrade, p. 907-924.
12. Zakić V. i Vasiljević Z. (2013): Uspostavljanje tržišta robnih derivata u funkciji unapređenja agrosektora u Srbiji, Ekonomski vidici, vol. 18, br. 1, Beograd, str. 49-61.

AGRICULTURAL PRODUCTION IN THE REPUBLIC OF SERBIA WITH EMPHASIS ON THE SITUATION IN NISAVA DISTRICT¹

Zoran Simonović², Branko Mihailović³

Abstract

The main characteristics of the Serbian economy is relatively large percentage share of agriculture in the national economy compared to other countries in Eastern and Southern Europe, the slow implementation of the necessary land reforms and delay implementation of the law on restitution. These are just some of the elements that a lot of influence on agricultural production in Serbia. The country is through the agricultural policy in recent years wanted to have an impact on changes in the volume of production. The authors believe that agricultural production must be organized in a modern way, which means that such production requires labor productivity, which is at the industry level. This attitude is quite acceptable if one bears in mind that modern agriculture has to have intensive capital ie. She must have big capital. He just looks at the efficiency of agriculture over the achieved level of productivity, which is viewed through the ratio of the number of employees and the volume of arable land. What is reality is that productivity is low in both sectors. Low productivity of individual farms can be explained by the fact that it is burdened with a series of aggravating circumstances. Some of them are to be placed on the limited possession and work on it all household

¹ Paper is a part of the research at the project no. III 46006 - Sustainable agriculture and rural development in the function of accomplishment of strategic goals of the Republic of Serbia within the Danube region, and project TR-31051 - Improvement of biotechnological procedures as a function of rational utilization of energy, agricultural products productivity and quality increase, financed by the Ministry of Education, Science and Technological Development of the Republic of Serbia, for the project period 2011-2014.

² Zoran Simonović, Ph.D., Scientific Associate, Institute of Agricultural Economics, Volgina Street no. 15, 11060 Belgrade, Serbia, Phone: +381 11 697 28 58, E-mail: zoki@medianis.net.

³ Branko Mihailović, Ph.D., Senior Research Associate, Institute of Agricultural Economics, Volgina Street no. 15, 11060 Belgrade, Serbia, Phone: +381 11 697 28 42, E-mail: brankomih@neobee.net.

members. At the end, the authors have made a study on the state of agricultural production in Nisava district. The aim of the research is to analyze the results of the state in agricultural production.

Keywords: *agricultural production, marketing of agricultural products.*

Introduction

Serbia has favorable natural conditions for the development of various agricultural productions. As it is known, is located in a favorable area of north latitude, which is characterized by four seasons and four climate areas. It is therefore enabled the development of a variety of plant and animal production: cereals, industrial crops, fruits and vegetables, seeds and seedlings, herbs, and livestock. In addition to climate, land is the most important natural condition for the development and deployment of Agriculture. Soil fertility is subject to change and is under the direct influence of climatic, hydrological and biological changes and human activities.

Based on the data of the Government of the Republic of Serbia, our country has about 5,734,000 ha of agricultural land (0.56 ha per capita), of which 4,867,000 ha, and the surface area is arable land (0.46 ha per capita). In fact, about 70% of Serbia's territory is agricultural land, while 30% is woodland.⁴ According to the current state of arable land are mostly (90%) are privately owned - farmers, while the remaining 10% owned by the state and enterprises. Much of the arable land is acidic as a result of the uncontrolled use of chemicals, and in Vojvodina and the diaphragm, which succinctly reduces the production possibilities of agriculture and at the same time increasing production costs. On this basis, it is necessary to take cultural practices in order to improve soil structure, but also requires a greater use of organic fertilizers. If we observe the geographical northern part of Serbia, Vojvodina, major part of his flat, while the hilly and mountainous areas are in the central and southern part of Serbia. Lowland regions are located in the Pannonian Plain in its border areas, or in Mačva, Posavina, Pomoravlje, Stig and the Negotin Krajina. Each of these regions is suitable for a particular type of agricultural production. Thus the lowland region as it is already known suitable for mechanized crop and vegetable production, mountainous and

⁴ <http://www.arhiva.srbija.gov.rs/cms/view.php?id=1024>

hilly for fruit, wine-growing and cattle breeding, a highland for developing sheep and cattle and forestry.

Agricultural production and productivity

Agricultural production in Serbia in the period from 2004 to 2011 was uneven. The smallest volume of agricultural production recorded in 2007. Renewed growth of agricultural production recorded in 2008 and since 2009 the decline again, which continues in 2010 and 2011. (Table 1). This cyclical decline in the growth of agricultural production cannot justify transition.

Table 1. *Scope and structure of agricultural production, 1991-2011.*

	2004	2005	2006	2007	2008	2009	2010	2011
Index (previous year: =100)								
Agricultural production	119.5	95.0	99.7	92.0	108.5	101.0	101.1	100.9
Crop production	143.9	94.1	97.4	82.2	123.3	103.6	101.1	98.2
- farming	156.3	98.4	92.9	76.9	129.8	102.4	105.8	95.4
- fruit growing	102.8	75.5	126.8	110.7	98.4	108.3	81.1	119.3
- viticulture	94.3	56.7	140.4	98.3	105.6	115.6	76.5	98.4
Animal husbandry	99.6	102.3	97.4	100.4	97.1	96.5	101.1	100.2
Structure (%)	100.0	100.0	100.0	100.0	100.0	100.0	100.0	100.1
- crop production	59.1	47.9	50.0	45.0	55.9	51.8	50.0	49.4
- animal husbandry	40.9	52.1	50.0	55.0	44.1	48.2	50.0	50.6

Source: *Statistical Yearbook of Serbia, 2005, 2010, 2012.*

Approximately 63.7% of the territory of the Republic of Serbia is under agricultural land, which is in representation, solvency and how to use a very heterogeneous in space. Possessing with 0.64 ha of agricultural land per capita and relatively favorable soil and climate conditions, Serbia has large reserves for increasing the competitiveness of agricultural production without endangering the environment. Over 80% of total agricultural land used by family farms, while the remaining companies and cooperatives, with the still unresolved by the end of property rights, so that they do not know reliably area owned by the state, not the rights of former owners or their heirs, nor the terms and land protection. Analysis of the situation of agricultural land irrefutably indicates that restrictions on the sustainable use of agricultural land in Serbia are not agro ecological, but primarily the market, infrastructure, socio-economic and

institutional nature.⁵ The total area of agricultural land used for crop production during the last ten years, the observed decreased by about 1%. Thus a minimum reduction of farmland has shown us that in the period of transition in Serbia reduced the minimum area of utilized agricultural land. The greatest reduction of surface recorded in the period after 2004. The downward trend began to be stopped since 2009. In recent years (2005-2011) the surface of utilized agricultural land is around the level of 5.05 to 5.08 million hectares (Table 2). From this area of cultivated land occupied 3,300,000 hectares, meadows around 620 thousand hectares. Throughout the reporting period continued slight downward trend surfaces perennial plants, which occupy about 300 hectares.

Table 2. *Used agricultural area (UAA) and the production of some important plant products, 2000-2011.*

	2004	2005	2006	2007	2008	2009	2010	2011
Land area KII3 (000)	5,113	5,074	5,066	5,053	5,055	5,058	5,051	5,056
Arable land	3,344	3,330	3,318	3,299	3,302	3,301	3,295	3,294
- cereals	2,020	1,972	1,888	1,943	1,937	1,956	1,894	1,911
- potato	89	85	84	81	81	78	77	78
- sugar beet	61	64	72	79	48	61	67	56
- Oilseeds	307	330	344	302	332	302	342	339
- vegetables	292	285	284	282	281	276	273	272
- roughage	464	461	458	457	466	455	460	455
Growing crops	310	303	300	299	300	298	297	296
- orchards	244	239	238	240	242	240	240	240
- vineyards	66	64	62	59	58	58	57	56
Meadows	598	609	610	620	621	625	624	621
Production in (000 tons)								
- wheat	2,758	2,007	1,875	1,864	2,095	2,067	1,631	2,076
- corn	6,569	7,085	6,016	3,905	6,158	6,396	7,207	6,480
- sunflower	438	351	385	295	454	377	378	432
- sugar beet	2,814	3,101	3,189	3,206	2,300	2,798	3,325	2,822
- potato	890	970	930	743	844	898	808	892
- plum	425	304	556	681	607	663	427	582
- apples	184	198	240	245	236	232	240	266
- grapes	425	241	359	353	373	431	330	325

Source: *Statistical Yearbook of Serbia, 2005, 2010, 2012.*

Changes in the volume of crop production cannot be explained on the basis of weather conditions. The past few years in the reporting period were extremely dry. In the period from 2004 to 2005 were major rainfall that are favorably influenced to some crop plants, but the others did not.

⁵ Strategija prostornog razvoja Republike Srbije 2009-2013-2020, Ministarstvo životne sredine i prostornog planiranja, Republička agencija za prostorno planiranje, Beograd, 2009, p. 82.

Overwhelming was the drought during 2006, 2007 and 2008 to between 2009 and 2011, temperatures were normal for our climate.⁶ Despite these circumstances, generally speaking, there was a growth in the production of almost all crops. The exceptions to this rule are the orchards and vineyards. The reason for the decrease in the production of these crops is mainly due to the decreasing use of extensive peasant orchards.

Of all the arable land in the country, which amount approximately one billion hectares of wheat occupies about 23%. In Serbia, the wheat grown on an average area of about 2,000,000 hectares and achieved an average yield of 3 to 3, 5 tons per hectare.⁷ The reduction of sowing areas in the reporting period can be explained on the basis of the first two possibilities that there has been a decrease in production due to lack of interest of the producers and the second to the smaller sowing areas getting more and more products, and that our agriculture provides more raw materials for industry, that in the structure of diet increases consumption of vegetables and livestock that are rapidly evolving. Serbia is a country where there are important natural resources for the development of this branch of agricultural production. An aggravating factor in the development of animal husbandry is low valorization of natural resources.

Table 3. *Number of livestock and production of major livestock products, 1991-2009.*

	2004	2005	2006	2007	2008	2009	2010	2011
Number of cattle (000)								
Cattle	1,102	1,079	1,106	1,087	1,057	1,002	938	937
-Cow	742	721	684	648	624	585	544	546
Pigs	3,439	3,165	3,999	3,832	3,594	3,631	3,489	3,287
Sheep	1,586	1,576	1,556	1,606	1,605	1,504	1,475	1,460
Poultry	16,280	16,631	16,595	16,422	17,188	22,821	20,156	19,103
Production of meat and milk								
Cattle (000 t)	93	90	83	95	99	100	96	81
Pigs (000 t)	242	253	255	289	266	252	269	271
Sheep (000 t)	20	21	20	20	23	24	23	24
Poultry (000 t)	65	67	75	70	76	80	84	103
Milk (million liters)	1,593	1,616	1,602	1,562	1,548	1,489	1,472	1,445
Eggs (million units)	1,536	1,476	1,456	1,364	1,204	1,026	1,219	1,219

Source: *Statistical Yearbook of Serbia, 2005, 2010, 2012.*

⁶ <http://www.hidmet.gov.rs>

⁷ Munčan P., Živković D (2006): *Menadžment ratarske proizvodnje*, Poljoprivredni fakultet Zemun – Beograd, p. 109.

The largest increase in livestock production in the period 2000-2011, had a poultry production and for the 12%. In the period to 2004, this production was decreasing on average by 5%, as of 2005 began to grow again, a slight reduction was recorded in 2006 and 2007, and that in 2008 and 2009 again achieved an increase. The reduction was achieved by 2009 compared to 2008 and it was around 33%. Pig production in the period from 2000 to 2011 the year decreased by about 11%. The greatest reduction in the production of still happened in cattle and dairy industry for about 28.4% of the cattle in the production of approximately 19%. Throughout this reporting period produced an average of 1,550,000 sheep. In the transition period decreased milk production by an average of about 6%. After 2005, milk production is increasing year by year. The volume of production of beef, pork and mutton has not significantly changed throughout the period.

Based on these data we can conclude that animal production in the reporting period from 1991 to 2011 has recorded a slight decline that is present from year to year. This is a kind of crisis of agricultural production which is characterized by a reduction of livestock production in all its forms. The basic aim of raising cattle is to obtain the major products (milk, meat, leather), followed by secondary (manure, axis).⁸ Despite the number of cattle in the last few years there has been a tendency to fall. Quantity of pigs from year to year changes, although in recent years this number stabilized and recorded an increasing trend. Sheep production shows oscillations in the period from 2009 to 2011. The increase in production was recorded in poultry.

We wish to point out that the state wants to pay special attention to the development of livestock production. The best example of our argument represents the Spatial Plan of the Republic of Serbia, where the question is raised livestock production ambitious. The plan envisages an increase in livestock throughout Serbia, particularly in Vojvodina, with a view to fuller utilization of agricultural land. Ten municipalities in Serbia is covered by programs revival of livestock farms.⁹ This seeks to encourage the production especially in swine, sheep and goat breeding. In practice, most households lack hygienic conditions for cattle. The number and composition of livestock is far below the potential of the feed base. According to the latest draft of the spatial plan of the Republic of Serbia

⁸ Ostojić, M. (2006): *Zlatarski sir*, Institut za ekonomiku poljoprivrede, Beograd, p. 115.

⁹ Đekić, S. (2010): *Agrarni menadžment*, Ekonomski fakultet, Niš, p. 86.

provided for the development of pasture cattle-breeding and re-introduction of indigenous breeds of livestock rearing.¹⁰ Some of the goals of the new law on animal husbandry are the conservation of genetic variation and biological diversity in livestock breeding, production of sufficient quantities of high-quality livestock products, the implementation of organic production in livestock, breeding of domestic animals with regard to environmental standards and so on.¹¹ Finally we point out that the intensification of livestock production and increasing the participation of industry in the structure of the agricultural production can provide encouraging shift racial composition of cattle and increasing the production of meat and milk per unit of capacity.

Be sure that the changes in the volume of agricultural production affected by the agrarian policy and that in several ways. Some of these ways are providing more favorable market conditions (price policy) and giving budgetary support to producers. It is best to influence agricultural policy can be seen in the case of apple production. The areas below the apples were all over this period increased, and this is the period in which the state subsidized the means to improve the production and stem fruit plantations.

Table 4. *Average yields of major agricultural products, 2000-2011.*

	2004	2005	2006	2007	2008	2009	2010	2011
Yields per hectare, tone (per tree, vine, kg)								
wheat	4.3	3.6	3.5	3.3	4.3	3.6	3.4	4.2
corn	5.5	5.8	5.1	3.2	4.8	5.3	5.9	5.1
sunflower	2.3	1.8	2.1	1.9	2.4	2.4	2.2	2.5
sugar beet	46.6	48.2	44.6	40.6	47.8	45.6	50.0	50.7
potato	11.0	11.4	11.0	9.3	10.4	11.5	11.6	11.4
plum	13.2	7.1	13.3	16.2	14.5	15.9	10.4	14.3
apples	12.3	13.4	16.4	16.3	15.5	18.1	15.1	16.6
grapes	1.2	0.7	1.1	1.1	1.2	1.5	1.1	1.2
Milk production per cow milkers	2,427	2,568	2,645	2,663	2,731	2,852	2,794	2,865

Source: *Statistical Yearbook of Serbia, 2010, 2012.*

On the other hand, an example of the poor functioning of agricultural policy is the lack of support for a production that gives good results. This is a production of sugar. Annual sugar production in Serbia is between

¹⁰ Prostorni plan Republike Srbije 2010-2014-2021 (nacrt), Ministarstvo životne sredine i prostornog planiranja, Republička agencija za prostorno planiranje, Beograd, februar, 2010, pp. 68-78.

¹¹ Službeni Glasnik RS, br 41/09, p. 178.

450,000 to 500,000 tons, and export quota to the EU from Serbia is 180,000 tons. In all the reports on the export of goods from Serbia sugar occupies one of the first cities, with about 180 million Euros of profit, which significantly improves the balance of payments of Serbia. Country Serbia does not give special subsidies to beet producers or the incentives to export sugar. Despite all that sugar beet production is stable and yields per hectare are good and amounted on average in the reporting period 2000-2011 year, slightly more than 40 tons (Table 4). In cattle agricultural policy could not prevent the decline in production. There was a decrease in the number of cattle and the number of cows. Number of dairy cows began to fall with an increase in milk production per dairy cow (specialization in terms of race and breed). Throughout this period of transition the country is carried subsidize livestock production. In the end we can say that in spite of all modern management concept in the transition period affected the changes in the volume of production. Modern organization of agricultural production requires labor productivity, which is at the industry level. This attitude is quite acceptable if one bears in mind that modern agriculture has to have intensive capital or she must have big capital. The efficiency of agriculture is seen through the achieved level of productivity observed through the ratio of the number of employees and the volume of arable land. The fact is that productivity is low in both sectors. Low productivity of individual farms can be explained by the fact that it is burdened with a series of aggravating circumstances. Some of them are to be placed on the limited possession and work on it all household members.¹²

In Serbia, there are significant differences between the productivity of labor on farms and farmers in agricultural enterprises, and the differences are primarily related to an increase in labor productivity on farms farmers.¹³ Increased labor productivity in agriculture means that more food per capita. In developed countries there is a tendency to produce higher productivity occupying a significant part of production capacity. Labor productivity is expressed in the total income or income per employee, expenditure of human and machine work required to produce 100 kilograms of certain agricultural products, the amount of the realized yield of agricultural produce per hour of labor expended so.¹⁴ For the purpose

¹² Zakić, Z. (2001): *Agrarna ekonomija*, CID, Ekonomski fakultet Beograd, pp. 179-180.

¹³ Đekić, S. (2005): *Ekonomika poljoprivrede*, Sven, Niš, p. 214.

¹⁴ Simonović, D., Đekić, S. (2000): *Ekonomika poljoprivrede*, Ekonomski fakultet, Niš, pp. 270-273.

of evaluating the economic efficiency of labor expended in the agriculture of the Republic of Serbia, can be used several criteria which reflect labor productivity. Taking into account the global labor productivity and available statistical data, for the purposes of further research we have chosen to follow the criteria that the ratio between the index of total agricultural production and the index of employment in agriculture. The aforementioned criteria show the total agricultural production, globally, achieved with the number of employees in agriculture. Tends to reduce agricultural production in the period from 1989 to 2000 is determined by the unfavorable economic conditions and a decline in relative prices in agriculture and reduction of investments in the manufacturing process, mainly bio-chemical inputs. All this is a logical consequence of the earlier economic in qualitative terms, the extensive development process, but also decrease the efficiency of production factors and the absence of a positive impact of organizational technical improvements and structural changes.¹⁵

Table 5. *Labor productivity in agriculture Serbian-expressed through the total agricultural production and the index of employed in agriculture (%)*

Specification	Years							
	2004	2005	2006	2007	2008	2009	2010	2011
The index of total agricultural production	124.4	98.7	88.1	112.4	101.8	91.9	101.1	100.9
Index of employment in agriculture chain	94.3	91.3	90.6	92.3	97.8	92.2	-	-
Employees in social sector	59,694	54,523	48,380	45,578	40,007	36,872	34,269	30,802
The index of total agricultural production /Index employed in agriculture	131.9	108.1	97.2	121.8	116.0	99.7	-	-

Source: *Statistical Yearbook of Serbia for the corresponding year, Editions Republic Institute for Statistics, Belgrade; Employment statistics, RZS Serbia, Belgrade 2004th*

¹⁵ Gajić, M., Lovre, K., Zekić, S. (2002): „Razvojne karakteristike poljoprivrede Srbija“, *Institucionalne reforme i tranzicija agroprivrede u Republici Srbiji*, Ekonomski fakultet Beograd, p. 179.

As the base was taken in 2004 years, and the time period covered by the analysis (2004 to 2011), it can be concluded relatively favorable trend in the movement of the total agricultural production as a direct consequence of the changes in the socio - economic system of the country. The ratio of total agricultural production index and the index of employment in agriculture was observed in all years over the unit value, the highest level in 2004, 132.9%. This certainly points us to the conclusion that the growth of agricultural production, the result of positive developments in labor productivity.¹⁶ In order to more fully express what aggregate productivity, science has determined a new concept of calculating productivity by using, among other superlative index Laspeyres's index of quantity, because of its simplicity and Tornqvist's index, which is more comprehensive because it incorporates changes in price base and current period, thus enabling the expression of marginal productivity in the period.¹⁷

We note that the main characteristic of the Serbian economy relatively large share of the share of agriculture in the national economy compared to other countries in Eastern and Southern Europe, the slow implementation of the necessary land reforms and delay implementation of the law on restitution. These are just some of the elements that a lot of influence on agricultural production in Serbia. The country is through the agricultural policy in recent years wanted to have an impact on changes in the volume of production. It can be seen that there is a desire to be in our agricultural production is organized in a modern way, which means that such production requires labor productivity, which is at the industry level. This attitude is quite acceptable if one bears in mind that modern agriculture has to have intensive capital ie. she must have big capital.¹⁸

Agricultural production in Nisava district

The aim of the research was to examine the agricultural production. For this survey prepared a special questionnaire. Nisava district power it has

¹⁶Cvijanović, D. V., & Subić, J. (2005): "Ocena produktivnosti rada u poljoprivredi Srbije", *Ekonomika*, 51(3), pp. 38-39.

¹⁷ Drobac, M. M. (2008): "Značaj faktora proizvodnje u merenju produktivnosti u poljoprivredi - teorijski aspekt", *Ekonomika poljoprivrede*, 55(1), pp. 39-40.

¹⁸ Simonović, Z., Mihailović, B., & Subić, J. (2016). Measure of Agricultural Policy in the Republic of Serbia With Emphasis on the Situation in Nisava District. *Facta universitatis - series: Economics and Organization*, 13(2), pp. 205-215.

under the state from 2012, 31.709 farms. If you take a sample of 0.5% then to 159 households to be interviewed (see table).

Table 6. *Number of holdings according to the state authorities Nis 2012th.*

Municipality	Agricultural holdings	The required number of polling 0.5%
Aleksinac	7,116	36
Gadžin Han	2,159	11
Doljevac	3,733	19
Meršina	3,074	15
Niš	10,244	51
Ražanj	2,332	12
Svrljig	3,051	15
In total	31,709	159

Source: *Department of Statistics and calculation authors.*

The most common are farmers in the city of Nis and Aleksinac municipality, five other municipalities follow them in a smaller, or about the same percentage.

Table 7. *Municipality's carrier according to the structure of agricultural holdings in%*

Municipality	participation in %
Niš	32.08
Alekainac	22.64
Svrljig	9.43
Merošina	9.43
Ražanj	7.55
Gadžin Han	6.92
Doljevac	11.95

Source: *Author's calculations based survey*

Education of the farms in this parts of Serbia is mostly medium (60%) while the Main-digit number (28%). Just over 10% of the holders of farms come with college and university education.

Table 8. *Education of agricultural holdings according to the structure in%*

answers of respondents	participation in %
yes	40.88
no	57.23
no answer	1.89
in total n=159	100.0

Source: *Author's calculations based survey*

Over 78% of households in the Nis area is registered in the single register of agricultural holdings.

Table 9. *Registered farms in percentages*

answers of respondents	participation in %
yes	78.62
no	21.38
in total n=159	100.0

Source: *Author's calculations based survey*

More than the obvious difference in the average size of arable land between registered (5.2 ha) and unregistered (2.5 ha) of agricultural holdings. The difference is observed with the lease of land so we have to almost three times more work the land registered farmers. Registered households on average pay pension contributions (36%) than non-registered (6%), i.e. exactly five times more. Registered farms are mainly engaged in animal husbandry, farming and fruit growing, while the unregistered to a large extent dominated by vegetable crops.

Table 10. *Holders of households who independently pay contributions for pension and health insurance*

answers of respondents	participation in %
yes	29,75
no	70,25
in total n=159	100,0

Source: *Author's calculations based survey*

Nearly one-third of respondents in this part of Serbia alone pay contributions for pension and health insurance.

Table 11. *Types of holdings on the basis of the very sources of income*

type farms	participation in %
Agricultural holding	46.54
A mixed farm	50.31
Non-agricultural farm	1.89
no answer	1.26

Source: *Author's calculations based survey*

Arable land on average is between 4.6 and 6.1 hectare. There are few major deviations from the average arable leased area because there are farms that lease the entire 50 hectares of arable land. Generally adding all surfaces, we conclude that the non-rented (720 ha) two times greater than the leased area (325 ha).

Table 12. Primary production in the Nis district

	number of holdings	%
Field Crop Production	35	22.0
animal husbandry	41	25.8
Vegetable Crops	35	22.0
viticulture	6	3.8
beekeeping	5	3.1
fruit growing	31	19.5
no answer	6	3.8
in total	159	100.0

Source: *Author's calculations based survey*

The table clearly shows the presence and orientation of agricultural holdings towards a particular type of production. Livestock and farming are the main commitment, and nothing less Vegetable and fruit growing, while viticulture and beekeeping at the level of statistical error, ie. do not exceed 5 percent.

Table 13. Secondary production in the Nis district

	number of holdings	%
Field Crop Production	26	16.0
animal husbandry	22	13.8
Vegetable Crops	14	8.8
viticulture	4	2.5
beekeeping	2	1.3
fruit growing	10	6.3
no answer	81	50.9
in total	159	100.0

Source: *Author's calculations based survey*

There are farms in this part of Serbia whose basic production are organized and auxiliary (78 seed farms and performs other tasks on the farm). So we have the question of agricultural orientation surveyed gave opportunities to enroll all activities that farm deals with the next base. Farms are oriented mainly on crop and livestock production.

Table 14. Methods of selling products in Nis district as a first option

	number of holdings	%
Through cooperative	17	10.7
Personally at the market	97	61.0
Enterprises	17	10.7
Through the customer	14	8.8
Direct manufacturing	9	5.7
no answer	5	3.1
in total	159	100.0

Source: *Author's calculations based survey*

The first option of choice in the realization of the production is sold to the person, to the market in 61% of cases, followed by co-operatives and enterprises with 10%, and a slightly smaller number of dealers is over.

Table 15. *Other selling methods as the second option that defines respondents in Nis district*

Type sales	number of holdings	%
Personally at the market	2	1.3
Enterprises	6	3.8
Through the customer	14	8.8
Direct manufacturing	15	9.4
no answer	122	76.7
in total	159	100.0

Source: *Author's calculations based survey*

Holders of households who reported another option selling has 37. These are mainly ways to sell directly to processors over of dealers.

Table 16. *The biggest constraints to agricultural production in the Nis district*

	number of holdings	%
Placement	102	64.2
Financial resources	16	10.1
Belonging to an association or cooperative	6	3.8
Low support from the agricultural budget	35	22.0
in total	159	100.0

Source: *Author's calculations based survey*

The largest number of carrier's surveyed households stated that marketing of agricultural products is a major constraint, is also not a small number of those who are committed to the biggest limitation are the lack of support from the agricultural budget of the country.¹⁹

Conclusion

Agriculture Serbia thanks to his own capacities can satisfy the domestic food market in agricultural products, because all the products except

¹⁹ Simonović, Z., Mihailović, B., & Milovanović, Z. (2016). Cooperatives and Farmers Association as a Model of Entrepreneurship in Serbian Agriculture Regarding the case of Nisava District. *Ekonomika poljoprivrede*, 63(2), p. 709.

citrus fruit. On the other hand, the market supply of food and agricultural products in Serbia is not regulated by the standards prevailing in the EU countries. Lack of appropriate legislation by the standards of the European Union creates opportunities to come to the creation of specific problems. A specific problem in agricultural production is the existence of several processors, and buyers of agricultural products that have significant market share and market power. These processors or buyers of agricultural products dominate in most markets of primary agricultural products: the market of wheat, sunflower, soybean, sugar beet, milk and tobacco. The business environment in this area is characterized by: a small domestic market, the difficulties in the placement, especially exports, high technological requirements of agricultural production, the standards in the system of food safety and quality requirements and the EU, etc.

The offer of agricultural products and foods is a large number of small farmers who are old and poorly educated and have little economic power. The works of these agricultural producers are characterized by subsistence or subsistence production. They have small investment opportunities in refrigerators, dryers, silos, increase in production and its standardization. There is no or weak organization of farmers through associations and cooperatives. From our prior discussion, it appears that there are a large number of manufacturers that there is not enough production to meet the needs of their own so-called. Large customers, but at the same time have a great offer and difficult placement in the local market. In the existing purchase and payment flows that van regularity, there is a large percentage of the market of primary agricultural products, which certainly promotes unfair competition. This situation is primarily due to poor law enforcement and inefficient labor inspection authorities. Not being purchasing and distribution centers and agricultural cooperatives whose role would be that of agricultural producers take over the function of sales and distribution.

Literature

1. Birovljev, J., Vojinović, Ž., Balaban, M. (2015): *Mogućnosti poljoprivredne proizvodnje i njihov uticaj na premiju osiguranja*, Ekonomika poljoprivrede, 62(3), str. 705-722.

2. Drobac, M. M. (2008): *Značaj faktora proizvodnje u merenju produktivnosti u poljoprivredi - teorijski aspekt*, Ekonomika poljoprivrede, 55(1), str. 39-40.
3. Vukelić, N., Rodić, V. (2014): *Menadžerski kapaciteti farmera kao faktor uspešnosti poljoprivredne proizvodnje*, Ekonomika poljoprivrede, 61(3), str. 805-814.
4. Gajić, M., Lovre, K., Zekić, S. (2002): *Razvojne karakteristike poljoprivrede Srbija*, Institucionalne reforme i tranzicija agroprivrede u Republici Srbiji, Ekonomski fakultet Beograd, str. 179.
5. Đekić, S. (2005): *Ekonomika poljoprivrede*, Sven, Niš.
6. Đekić, S. (2010): *Agrarni menadžment*, Ekonomski fakultet, Niš.
7. Zakić, Z. (2001): *Agrarna ekonomija*, CID, Ekonomski fakultet Beograd, str. 179-180.
8. Komazec, L., Aleksić, M. (2015): *Organska poljoprivredna proizvodnja u funkciji smanjenja ruralnog siromaštva - primer vođanskog sela Velebit*, Ekonomski horizonti, 17(2), str. 155-163.
9. Mihailović, B., Cvijanović, D., Simonović, Z. (2015): *Uloga poslovne etike u menadžmentu ljudskih resursa*, Ekonomika, 61(1), 85-96.
10. Munćan, P., Živković, D. (2006): *Menadžment ratarske proizvodnje*, Poljoprivredni fakultet Zemun - Beograd.
11. Ostojić, M. (2006): *Zlatarski sir*, Institut za ekonomiku poljoprivrede, Beograd.
12. Prostorni plan Republike Srbije 2010-2014-2021 (nacrt), Ministarstvo životne sredine i prostornog planiranja, Republička agencija za prostorno planiranje, Beograd, februar, 2010, str. 68-78.
13. Simonović, D., Đekić S. (2000): *Ekonomika poljoprivrede*, Ekonomski fakultet, Niš, str. 270-273.
14. Simonović, Z., Jeločnik, M., Vasić, Z. (2012): *Ekonomski položaj poljoprivrede Srbije u periodu tranzicije*, Ekonomika poljoprivrede, 59(3), 535-545.

15. Simonović, Z. (2014): *Upravljanje agrarom Srbije u tranziciji*, Institut za ekonomiku poljoprivrede, Beograd, str. 124-132.
16. Simonović, Z., Mihailović, B., Milovanović, Z. (2016): *Cooperatives and Farmers Association as a Model of Entrepreneurship in Serbian Agriculture Regarding the case of Nisava District*, *Ekonomika poljoprivrede*, 63(2), 699-712.
17. Simonović, Z., Mihailović, B., Subić, J. (2016): *Measure of Agricultural Policy in the Republic of Serbia With Emphasis on the Situation in Nisava District*, *Facta universitatis - series: Economics and Organization*, 13(2), 205-215.
18. Subić, J., Katić, B., Vuković, P. (2005): *Zemljište - najznačajniji prirodni resurs u poljoprivredi*, *Ekonomika*, 51(5-6), str. 49-56.
19. Službeni Glasnik RS, br 41/09, str. 178.
20. Statistički godišnjak Srbije 2005, 2010, 2012., Republički zavod za statistiku, Beograd.
21. Strategija prostornog razvoja Republike Srbije 2009-2013-2020, Ministarstvo životne sredine i prostornog planiranja, Republička agencija za prostorno planiranje, Beograd, 2009, str. 82.
22. Cvijanović, D. V., Subić, J. (2005). *Ocena produktivnosti rada u poljoprivredi Srbije*, *Ekonomika*, 51(3), str. 38-39.
23. Poljoprivreda, <http://www.arhiva.srbija.gov.rs/cms/view.php?id=1024> (14.04.2016).
24. Republički hidrometeorološki zavod, <http://www.hidmet.gov.rs> (14.04.2016).

III SECTION

***THE APPLICATION OF CLEAN
TECHNOLOGIES IN THE FUNCTION
OF DIVERSIFICATION OF THE
RURAL ECONOMY***

RURAL TOURISM IN THE SOUTH-MUNTENIA DEVELOPMENT REGION

Adrian Ungureanu¹, Bogdan Bazga²

Abstract

At the country level, in Romania rural tourism is a form of tourism which has increasingly drawn more interest, both from Romanian citizens and from foreigners, the analysis of the results shows significant differences between the seven counties of the South-Muntenia development region. The region is characterized by significant differences between counties in terms of their rural tourism. Thus, while Prahova, Arges and the north of Dâmbovița have developed both mountain tourism and rural tourism, counties such as Calarasi, Ialomita, Giurgiu, Teleorman and a large part of Dâmbovița are plain counties, where tourism is relatively limited, and in which, due to the decline of agriculture that led to a low standard of living, rural tourism offer is quite limited. This paper aims to identify the counties of South-Muntenia development region where the trends of development of rural tourism are significantly above the average recorded at country level, as a first step towards particular studies of sustainability in rural communities.

Key words: *rural tourism, agro-touristic boarding houses, overnight stays.*

Introduction

The rural tourism in Romania is a new phenomenon, in which, similarly to other regions of the world, agricultural workers and people living in rural areas are looking for some alternative sources of income (Fleischer, Pizam, 1997).

¹ Adrian Ungureanu, Ph.D., Lecturer, Petroleum-Gas University of Ploiești, Faculty of Economic Sciences, B-dul Bucuresti no. 39, 100680 Ploiești, Prahova, Romania, Phone: +40 723 561 211, E-mail: ungureanu_adrian2001@yahoo.com.

² Bogdan Bazgă, PhD, National Intelligence Academy „Mihai Viteazul”, Șoseaua Odăi nr. 20, sector 1, București, Romania, E-mail: bogdan.bazga@gmail.com

Rural accommodation is organized according to the type of the rural home. Some rural households are on agricultural land, and the owners, rarely stop their work while involved in rural tourism. The other, more common type, are rural homes not involved in agriculture, as well as small nonagricultural rural settlements, which may suggest that agriculture alone is not a necessary factor in rural tourism growth (Fleischer, Felsenstein, 2000) .

The positive influence of agrotourism on-farm family income may also be combined with the contribution the business makes to the local community via sales taxes, local employment and stimulation of local businesses such as restaurants and shops (Barbieri, 2009; Saxena, Clark, & Ilbery, 2007; Sharpley, 2007; Veeck et al., 2006)

The literature generally accepts that tourist holidays on family farms are associated with the romantic idea of the simple ways of life, untouched nature and the relationship of man and his natural environment. On the other hand, agrotourism has two different roles in the life of the owner; it is a business entity, but also a home.

The obligations of owners of agritourism are driven cycles arising from the nature of agricultural production, regardless of whether it is crop production or livestock production, however, and tourism as an additional activity has its own requirements. (Busby, Rendle, 2000; Nilsson, 2002, Di Domenico, Miller, 2011)

In Romania, studying the evolution of agroturistic boarding houses is based on absolute values recorded between 2005 (956 agroturistic boarding houses) (Zaharia, Gogonea, Andrei, 2016) and 2015 (1,918 agroturistic boarding houses).

The paper proposes an analysis of the evolution of South-Muntenia development region rural area in its multiple guises, with emphasis on rural development under the concepts of sustainability and multi-functionality. The rural areas are rich in their ecological and cultural diversity. The dimension and complexity of the rural communities make difficult a generalization regarding their problems or values, even if some common characteristics exist. Rural tourism represents an important segment of the Romanian touristic district, being continuously developed in the analyzed time table (2005–2015). The rural tourism from the developing region of South-Muntenia presents a multitude of problems due especially to an insufficient promotion of rural touristic areas, as touristic destinations, poor advertisement of traditional rural events,

tourist's inadequate information, general infrastructure but also poorly developed tourism.

Our country has a great possibility of tourism development in the rural area, and practicing it is necessary in the current stage. (Nistoreanu, Tigu, Popescu, Padurean; Talpes, Tala, Condulescu, 2003)

For the next term, 2015-2020, I think that the rural tourism of the analyzed region can become a real engine for local economy. Through the development of the rural tourism, a series of positive effects could be achieved, such as: economic development and social equilibrium of the rural space, creating new jobs, fastening the integration of rural communities, improving the quality of life, conservating and developing the cultural diversity, and rising the income of the population from the rural area. In South-Muntenia development region the issues concerning rural development, development of rural area is analyzed at the level of 519 communes in 2015, the smallest territorial units to which the rural development policy that span the 7 counties. Rural areas in South-Muntenia cover 88.22% of the development region, comprising 60.48% of the population, namely 1,859,098.

Methodology and data sources

To make a proper forecast for the next five years of the number of overnights and total arrivals, three adjustment methods will be used, the linear trend method, average time index method and average absolute change. After comparing the coefficient of variation obtained for every method with the 5% limit on the data shown above, the method with the lowest value will be chosen for the forecast.

To achieve the research objectives we chose to based on data taken from official documents and the official data series provided online by the National Institute for Statistics of Romania (2016) on the above-mentioned indicators, for the period from 2005–2015, and for the following counties of the South-Muntenia development region, Argeş, Călăraşi, Dâmboviţa, Giurgiu, Ialomiţa, Prahova, Teleorman.

Information base has formed scientific publications of Romanian and foreign authors related to the problem under consideration and the supplies statistics tourist potential of INS, data reports county division of statistics from 2005 to 2015 and other official documents in Romania, Regional Development Ministry materials and public administration, as well as forecasts, author's calculations and estimates.

Demographic evolution of the rural development region South-Muntenia

The population of South-Muntenia development region is on a high point, the population share of rural population being 57.09% in 2016 (see Chart 1).

Rural population in the analyzed space has the highest population shares in Dambovita (67.95%), Giurgiu (67.35%) and Teleorman (63.57%) districts.

In gross values the population from rural environment places Prahova district on the first place with a population of 394,900, followed by Dambovita district with a population of 359,093.

Table 1. *Permanent resident population in South-Muntenia development region/county*

Region/County	Permanent resident population	Rural population	Share of rural population
Argeş	646,333	329,361	50.95
Călăraşi	317,293	190,203	59.94
Dâmboviţa	528,426	359,093	67.95
Giurgiu	276,781	186,433	67.35
Ialomiţa	293,658	154,431	52.58
Prahova	809,052	394,900	48.81
Teleorman	389,433	247,583	63.57
Sud-Muntenia	3,260,976	1,862,004	57.09

Source: *Own calculations based on*

<http://statistici.insse.ro/shop/index.jsp?page=tempo3&lang=ro&ind=ADM101A>,

<http://statistici.insse.ro/shop/index.jsp?page=tempo3&lang=ro&ind=POP106A>

The benchmark of the rural population indicates a uniform placement of the population in the 7 districts (see Table 1).

From the total rural population of the South-Muntenia development region (3,260,976), a massive share is held by Dambovita district (67.95%) and Giurgiu district (67.35%). At the opposite end is Prahova district with its share of rural population actually being the total rural population of the district, of just 48.81%.

Chart 1. Share of rural population in total rural population-South-Muntenia development region, 2016.

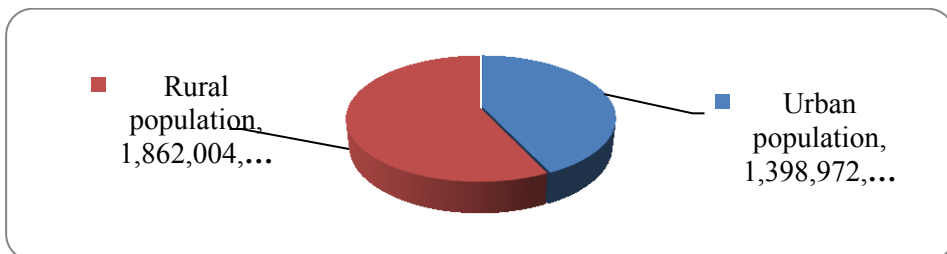

Source: Own calculations based on

<http://statistici.insse.ro/shop/index.jsp?page=tempo3&lang=ro&ind=ADM101A>, <http://statistici.insse.ro/shop/index.jsp?page=tempo3&lang=ro&ind=POP106A>

At regional level, in order to be able to final main rural development policies must be analyzed the rural population because this is the most dynamic component of the countryside and a potential resource of particular importance for the development of villages. (Câdea, Bran, 2001)

Birth rate

The transformations occurred in the last decades in the economic and social life, as well as in the people's mentality, managed to negatively influence the demographic behavior of rural population. The main demographic phenomena such as birth rate and mortality influences directly the dynamic of the rural population and has the most meaning through the consequences that are created in time. The analyze of the dynamics of these two components outlines that the dropping of birth rate in the rural area has the most implications, visibly influencing the demographic decline.

Table 2. The birth rate in rural areas, during 2005-2015- South-Muntenia development region

Counties/live births per 1000 inhabitants	2005	2006	2007	2008	2009	2010	2011	2012	2013	2014	2015
Argeş	12.8	9.5	9.2	8.6	9	9.3	8.9	8.4	8.3	8.1	8.2
Călăraşi	13.3	10.6	10.8	10.4	10.9	11	10	9.7	9.9	9.4	8.7
Dâmboviţa	13.9	10.1	9.6	9.4	10.1	10.3	10	9.3	9.3	9	8.8
Giurgiu	12.0	9.0	9.4	9.3	10.1	10.1	9.5	9.4	9.4	9.1	8.6
Ialomiţa	13.7	10.3	10.4	10.3	10.9	11.3	10.7	9.9	10	9.4	9.6
Prahova	12.5	10.6	9.9	9.7	9.2	9.9	8.8	8.1	8.3	8.2	8.1
Teleorman	10.9	7.3	7	6.8	6.9	7.6	7.2	6.6	7.1	7	7.1
South-Muntenia	12.7	9.6	9.4	9.1	9.4	9.8	9.2	8.6	8.7	8.5	8.4

Source: Own calculations based on

<http://statistici.insse.ro/shop/index.jsp?page=tempo3&lang=ro&ind=PO P202A>

If regarding the demographic data at the county level shall not be recorded major differentiation, comparative data on the rural population illustrates the existence of differentiated developments in the last ten years of the indicators on the birth rate and mortality. From the point of view of the evolution of the low birth rate, the path that even more dramatic was recorded in Teleorman county, where its value has dropped very much in recent decades, and the lowest reduction, although one rather consistent (3.8 ‰), it was recorded in the line of the rural population in Teleorman county.

In the period 2005-2015, South - Muntenia developing region is characterized in the rural areas through a rate of the birthrate something higher as compared with the urban areas, (see Chart no. 2), the downward trend is evidenced, from 12.7 ‰ in 2005 to 8.4 ‰ in 2015.

Chart 2. Evolution of the average birth rate in the period 2005-2015, (‰)

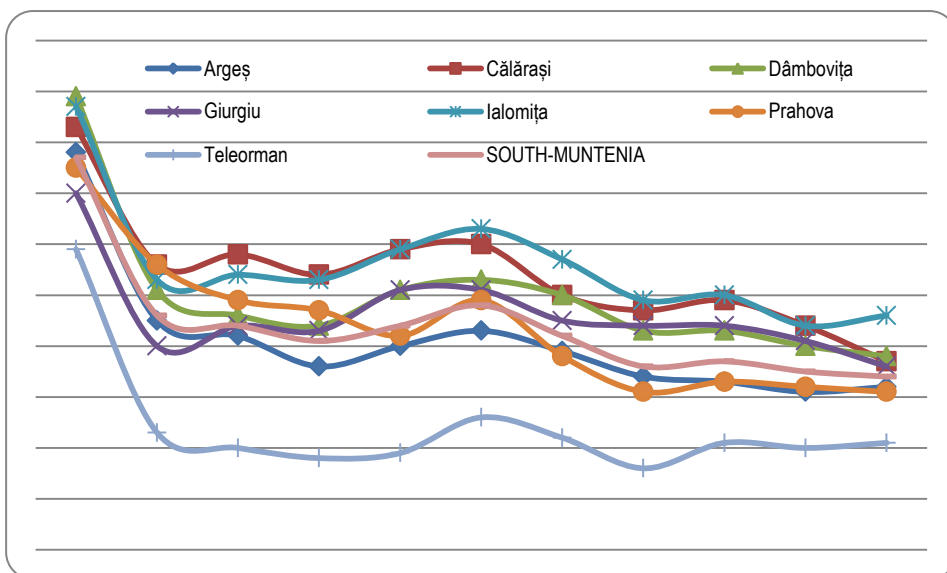

Source: Own calculations based on

<http://statistici.insse.ro/shop/index.jsp?page=tempo3&lang=ro&ind=PO P202A>

Inter-county level, it can be seen, as Chart 2 that, during the reporting period kept the downward trend in the birth rate both at regional and national levels.

In 2015, values above the average in rural areas in the South-Muntenia found in Ialomita (9.6 ‰) and Dambovita (8.8 ‰), while the lowest value of the birth rate is in the county Teleorman only 7.1 ‰ (7.1 live births per 1,000 inhabitants).

The intensity birth counties parts of South-Muntenia varies by level of education and is strongly influenced by the general level of culture, traditions and religious views and occupancy of the female population.

The trend of declining birth rates recorded in all the seven counties of the South-Muntenia and positive changes in this respect cannot occur unless the authorities intervene through measures stimulating demographic nature, the birth rate and natural growth developments.

In the current demographic, economic and social development of rural areas of Romania, any economic measure taken to redress the birth to be welcomed and appreciated.

And substantiation of such measures on a scientific basis and tracking the effects would increase efficiency and would reduce (if not eliminate) the potential adverse effects.

Mortality

Mortality rural population has evolved, as great as birth. The constant increase mortality due to increased mortality in adulthood before, and an increase in infant mortality. The difficulties faced by rural people, many of them elderly, in access to care and purchase of medicines has led to increased mortality.

The health system appears to have had a significant influence in this new resurgence of death, because it was installed around the age of 40, and the following age groups, in both sexes; that is, where starts to build, in general, the condition of acute and chronic human diseases.

Economic and social development means increasing per capita gross domestic product, and service quality, the health of which have an immediate impact.

If in 2005 there was an average of 15.9 ‰ gradually installed a stabilizing trend of the indicator values of 15 ‰ pasta, reading that in the rural areas in the South-Muntenia and analyzed over the past decade (see table 3 and chart no. 3).

Table 3. *The mortality rate in rural areas, by counties during 2005-2015, South-Muntenia development region*

Counties/ Deceased per 1000 inhabitants	2005	2006	2007	2008	2009	2010	2011	2012	2013	2014	2015
Argeş	15.3	14.8	14.5	14.4	14.4	15.1	15.1	14.7	14.3	14.5	14.7
Călăraşi	15.9	15.7	15.2	15.6	16	16.2	16	16.2	15.7	16	16.5
Dâmboviţa	14	14	13.3	13.5	13.3	13.4	12.9	13.2	13.4	13.1	13.3
Giurgiu	18.2	18.4	18.3	18.2	19	18.9	17.5	18.4	17.5	17.3	17.2
Ialomiţa	15.2	14.9	15.7	16	15.7	16.3	16.7	16.6	15.5	16.9	16.3
Prahova	13.6	13.7	13	13.4	13.5	13.6	13.3	13.7	13.3	13.3	13.9
Teleorman	21.3	20	19.6	20.1	21.1	20.5	20.4	20.9	19.5	20.7	21.1
South-Muntenia	15.9	15.6	15.2	15.5	15.7	15.8	15.5	15.7	15.2	15.4	15.7

Source: *Own calculations based on*

statistici.insse.ro/shop/index.jsp?page=tempo3&lang=ro&ind=POP207A

Regarding developments in mortality, it highlights two profiles county significantly different: on the one hand, Prahova County, the number of deaths from rural per 1,000 inhabitants was kept fairly constant in the last decade, and to some extent and Dambovita County; on the other hand, counties, Teleorman, Ialomita and Calarasi, where the rural population mortality rate increased significantly.

Very high mortality noted in Teleorman (21.1 ‰) and Giurgiu (17.2 ‰) in 2015, where the rural population age structure is somewhat unfavorable. In two counties, mortality is above the average of 13.9 ‰ as recorded in rural Romanian national.

On the other hand, in the northern part of South-Muntenia, overall mortality is lower in rural areas, due, in particular, a more favorable age structure of the population. Counties with lower mortality in rural areas are: Dambovita (13.3 ‰), Prahova (13.3 ‰) and Arges (14.7 ‰).

Chart 3. The evolution of mortality in the period 2005-2015, South-Muntenia development region, (%)

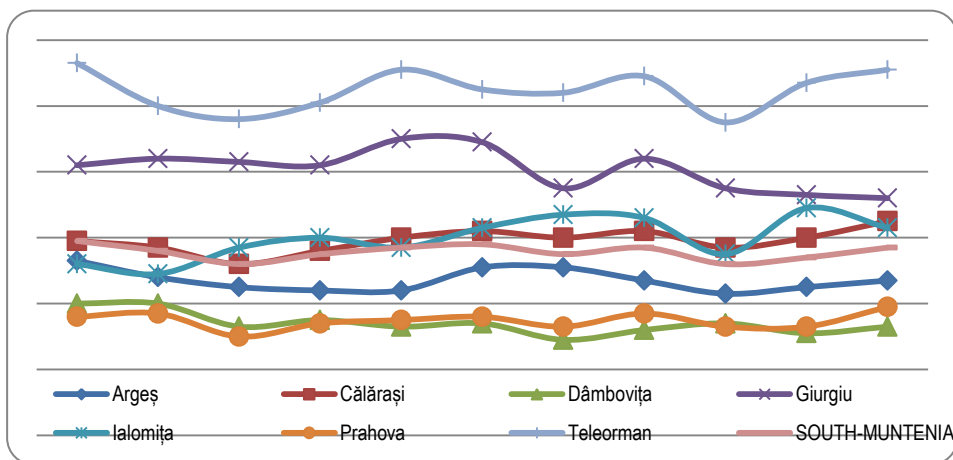

Source: Own calculations based on

statistici.insse.ro/shop/index.jsp?page=tempo3&lang=ro&ind=POP207A

That general mortality rural development will depend heavily on the age structure of the population. There are other factors of mortality rural population, namely: hygiene, cultural level of the inhabitants living conditions of residents, especially the provision of hospitals and specialized health personnel.

Table 4. Natural growth rate in rural areas, by counties during 2005-2015, South-Muntenia development region, (%)

Counties/ Natural growth rate per 1000 inhabitants	2005	2006	2007	2008	2009	2010	2011	2012	2013	2014	2015
Argeș	-2.5	-5.3	-5.3	-5.8	-5.4	-5.8	-6.2	-6.3	-6	-6.4	-6.5
Călărași	-2.6	-5.1	-4.4	-5.2	-5.1	-5.2	-6	-6.5	-5.8	-6.6	-7.8
Dâmbovița	-0.1	-3.9	-3.7	-4.1	-3.2	-3.1	-2.9	-3.9	-4.1	-4.1	-4.5
Giurgiu	-6.2	-9.4	-8.9	-8.9	-8.9	-8.8	-8	-9	-8.1	-8.2	-8.6
Ialomița	-1.5	-4.6	-5.3	-5.7	-4.8	-5	-6	-6.7	-5.5	-7.5	-6.7
Prahova	-1.1	-3.1	-3.1	-3.7	-4.3	-3.7	-4.5	-5.6	-5	-5.1	-5.8
Teleorman	-10.4	-12.7	-12.6	-13.3	-14.2	-12.9	-13.2	-14.3	-12.4	-13.7	-14
South-Muntenia	-3.2	-6	-5.8	-6.4	-6.3	-6	-6.3	-7.1	-6.5	-6.9	-7.3

Source: Own calculations based on

<http://statistici.insse.ro/shop/index.jsp?page=tempo3&lang=ro&ind=POP215A>

Natural growth calculated based on births and deaths, which is essential premise of numerical increase or decrease in the rural population, it follows a similar pattern to the two factors (birth and death rates), with differences by counties.

In South Muntenia development region for all counties observed in rural areas were registered during the same period only negative values. (See Chart no. 4.)

Chart 4. *The evolution of natural growth in rural areas during 2005-2015, South-Muntenia development region (%o)*

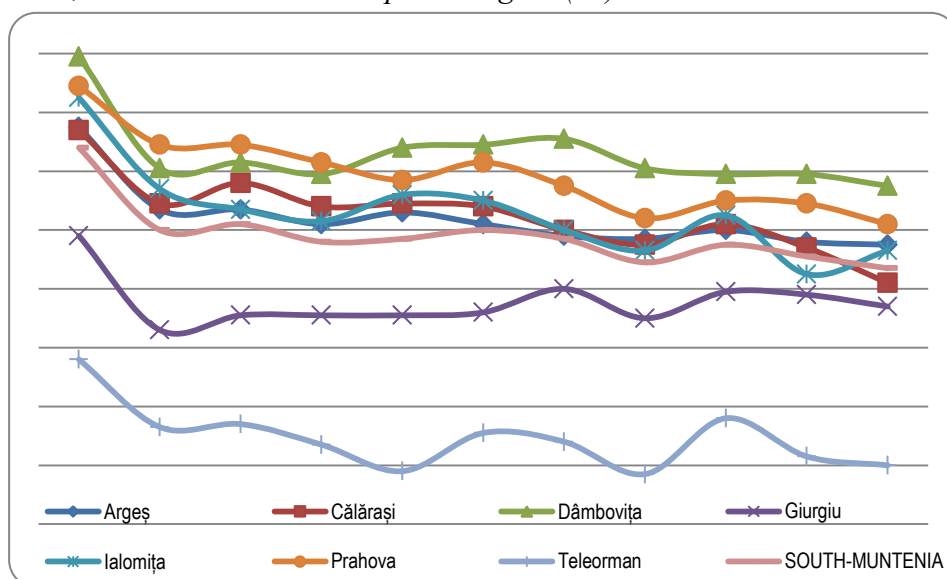

Source: *Own calculations based on*

<http://statistici.insse.ro/shop/index.jsp?page=tempo3&lang=ro&ind=POP215A>

The highest value recorded for the negative natural increase is -7.3%o in 2015.

A comparative analysis between counties natural increase of population, reveals a pronounced negative phenomenon in the Teleorman County in 2015 it recorded the lowest level of natural growth among counties of -14.0 %o. The greatest value of the natural growth of the rural population stands at 2015 in the Dâmbovița County -3%o.

Rural tourism potential in South-Muntenia Development Region

The region has a growing local tourist potential, becoming one of the most important economic sectors, its contribution to the socio-economic revival of the region is substantial. (Lascăr, 2015).

The rural tourism begins to take its rightful place in the context of pollution accentuation, and the existence of stressful life. In this context, modern man needs a revival through direct contact with nature and active involvement in the development of tourism activities, requirement that mainly rural tourism can satisfy much easier than any other form of tourism. (Zaharia, Ghiță, 2014)

Rural tourism can contribute to rural development, because it allows the use of resources specific to each area can revitalize traditions and crafts and also can be an alternative for agriculture in finding new solutions for employment. The importance of rural tourism lies in the fact that the Track is based form of tourism in terms of the types of receiving units, on facilities owned by private residents. The direct involvement of any villager who manages such a business can assist in improving quality of life without resorting to major investments. A specific form of rural tourism, which began to develop in the South-Muntenia is agro tourism, which involves a perfect blend of tourist services with agricultural activities at household or a firm. This form of tourism gives the tourist the opportunity to participate in various agribusiness activities. (Blanca Garcia Henche, 2004, p.44-45).

Rural tourism is considered an essential tool for economic diversification and regional jobs. In this case, examination of complementarities earnings agrarian families have less importance than in tourism, because operators do not necessarily have to work in agriculture. Rural tourism must be addressed as a response to the needs of small agricultural holdings, allowing family farmers to reach a standard of living to offset the hardships of rural life. Analysis of Development Region South-Muntenia highlighted the development of rural tourism in the mountains and Carpathian (North Arges, Dambovita and Prahova). And southern counties have rural tourism potential, untapped true value, namely by exploiting fisheries and wildlife that we possess. Agrotourism is a real opportunity for local economies. Between agrotourism and socio-economic development of rural areas there is a relationship of correspondence of reciprocity. It is recognized that complex agro exert influence on the external environment (economic, social, cultural)

development was taking its toll on the overall development of the area. Based existing accommodation in the countryside is essential for tourism to develop because, by definition of rural tourism, it states that the tourist be checked and carry out tourism activities in rural areas. Thus, nationally main types of units we encounter in rural guest houses, secondary residences (holiday homes), cabins, motels and hotels. However, the possibilities for accommodation in rural areas are diverse, according to the household availability and wishes and demands of tourists.

Evolution of accommodation structures in rural resorts

Specific rural accommodation base (agrotouristic boarding houses) is completed and the units hostel in the outskirts of urban areas (where appearance households and individuals are characteristic of rural occupations), in whose tender submitted deployment services are found in rural areas. There are cases when the accommodation are in the towns urban services focused on rural areas.

Chart 5. *Evolution of agrotouristic boarding houses in the period 2005 – 2015, South-Muntenia Development Region, (number of units)*

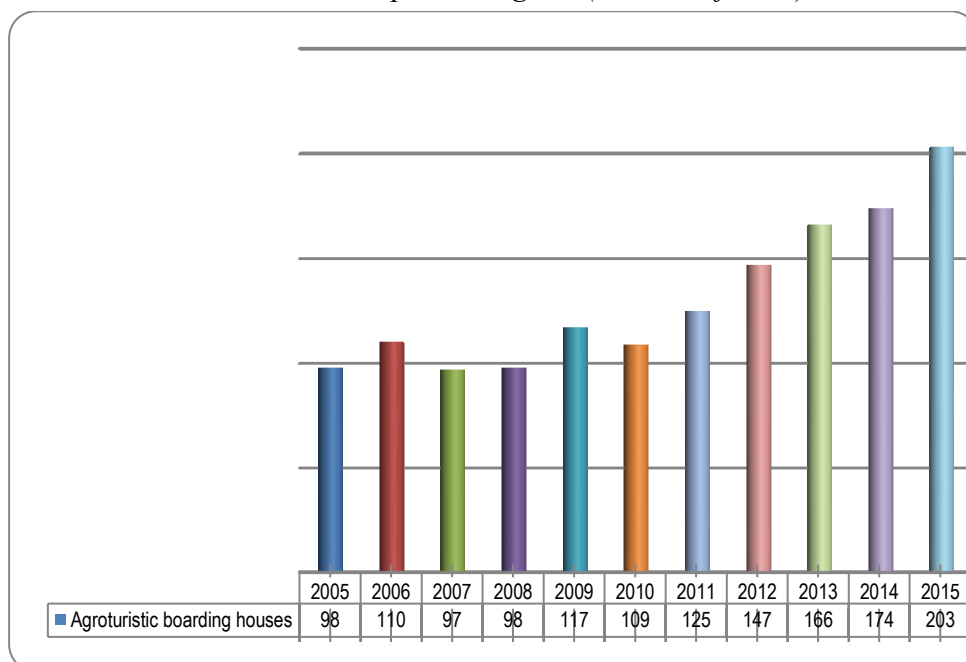

Source: *Own calculations based on*

<https://statistici.insse.ro/shop/index.jsp?page=tempo3&lang=ro&ind=TUR101A>

Inter-county level stands the Argeş County where the number of agrotouristic boarding houses had reached 136 in 2015, representing 66.9% of total agrotouristic boarding houses.

In the analyzed period, according to data from the National Statistics Institute that was processed in the following chart it can be noticed a significant increase in accommodation structures in rural areas from 98 to 740 agrotouristic boarding houses in South-Muntenia Development Region.

Significant increases were recorded in the Dâmbovița county (from 8 in the year 2005-24 agrotouristic boarding houses in 2015), and Prahova County (from 27-36 units of agrotouristic boarding houses).

Chart 6. *Evolution of agro-touristic boarding houses, by counties, between 2005 – 2015 (number of units)*

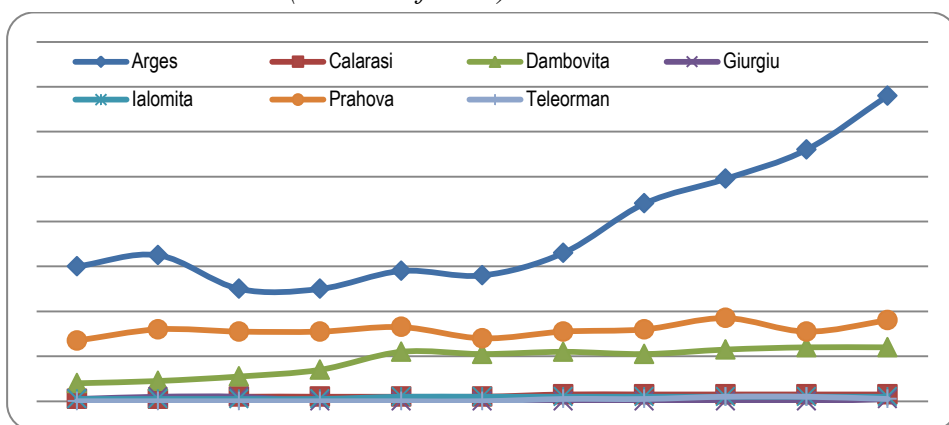

Source: Own calculations based on:

<https://statistici.insse.ro/shop/index.jsp?page=tempo3&lang=ro&ind=TUR101A>

Lack of financial resources has led many residents of rural areas to use the surplus held in spaces for tourists and hostel accommodation agritourism. These farms provide both tourist accommodation and living space for the owners.

Development of rural tourism in recent years has achieved uncoordinated, in the absence of a coherent vision and strategic. Poor in rural tourism activity can be due to: inadequate infrastructure systems and communications; poor systematic planning; and poor cooperation between local and national authorities. (Scutariu, 2011).

Chart 7. Share of agrotouristic boarding houses in total, by counties in South-Muntenia Development Region-2015

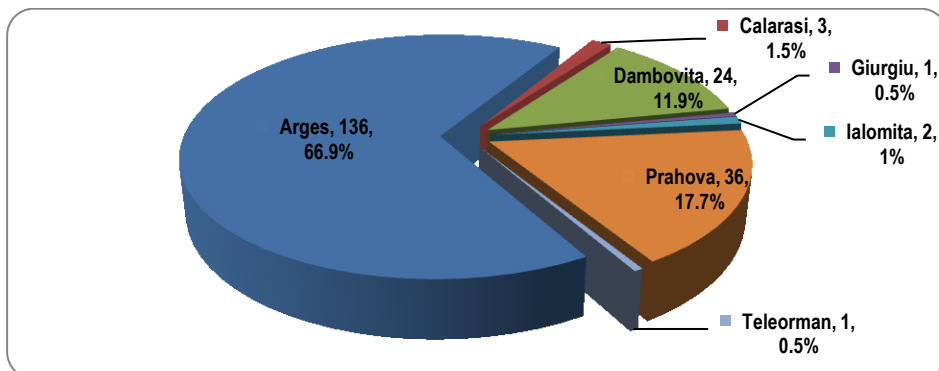

Source: Own calculations based on:

<https://statistici.insse.ro/shop/index.jsp?page=tempo3&lang=ro&ind=TUR101A>

Steady increase in the number of agrotouristic boarding houses in all counties covered under observation, led by 2015 the following share by counties:

- Argeş county: 136 (66.9% of those approved);
- Călărași county: 3 (1.5% of those approved) ;
- Dâmbovița county: 24 (11,9 % of those approved);
- Giurgiu county: 1 (0.5% of those approved);
- Ialomița county: 2 (1.0% of those approved);
- Prahova county: 36 (17.7% of those approved);
- Teleorman county: 1 (0.5% of those approved).

The total accommodation capacity is 3,582 units approved tourist beds in the year 2015.

It stands Argeş county, which in 2015 recorded 2,366 beds, representing 66.05% of the total accommodation places in rural areas (development region South-Muntenia).

At regional level, second position is occupied by Prahova County with 624 beds (17.42%).

The total accommodation capacity is 740 units of Approved units, with a capacity of 3,582 beds in rural locations.

Chart 8. Evolution of agrotouristic boarding houses in the period 2005 – 2015 (number of seats)

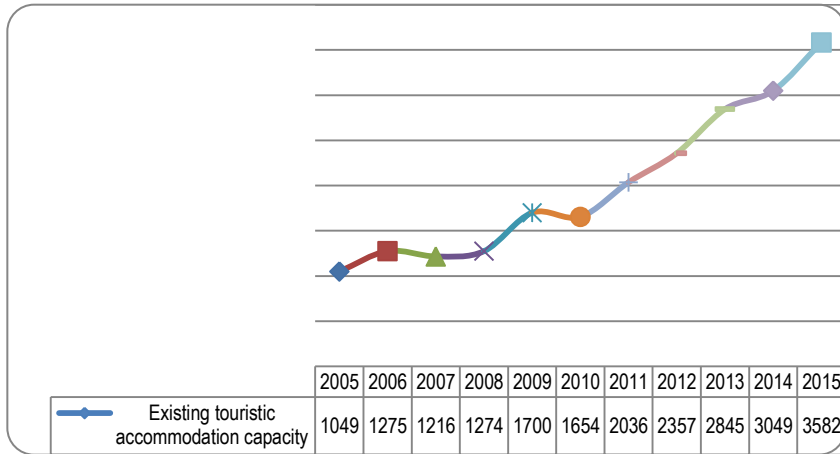

Source: Own calculations based on

<https://statistici.insse.ro/shop/index.jsp?page=tempo3&lang=ro&ind=TUR101C>

Since the average growth index is greater than 100% appreciate that recorded significant progress. Dynamics of the number of beds in agro-touristic boarding houses in the period 2005-2015 recorded in 2015 a maximum of 533% compared to 2005, when it was recorded the lowest for the period. During 2005-2015, in South -Muntenia development region, the capacity of tourist accommodation in rural agrotouristic boarding houses recorded an annual average of 253,3 seats, an increase of 2,003.36 positive environment places, which is an annual progress relative to 18.4%.

Chart 9. The evolution of agro-touristic boarding houses, by counties between 2005 – 2015 (number of seats)

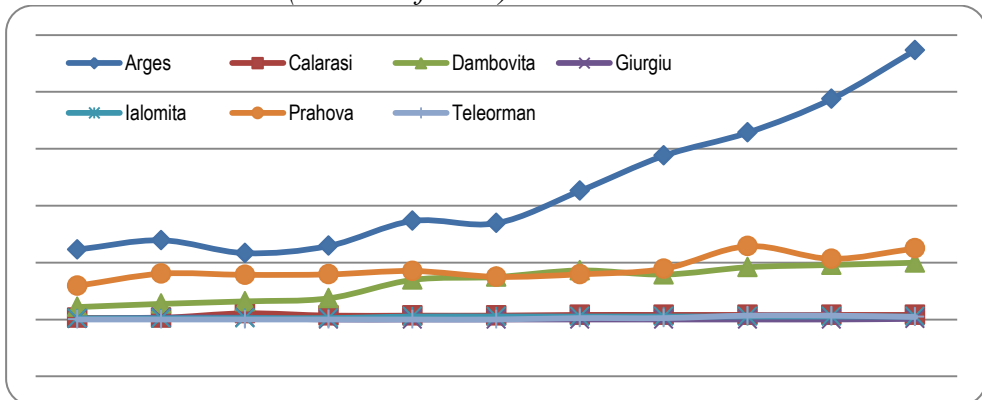

Source: Own calculations based on:

<https://statistici.insse.ro/shop/index.jsp?page=tempo3&lang=ro&ind=TUR101C>

At the level of the 7 counties are detached the Argeş county where the growth of the number of beds in agrotouristic boarding houses during 2005-2015 record maximum of 429% (2,366 seats) in 2015 compared to 2005 when it was recorded the lowest for the period under review (614 seats).

Chart 10. *The share of accommodation in agro-touristic boarding houses in total pensions, by counties-2015*

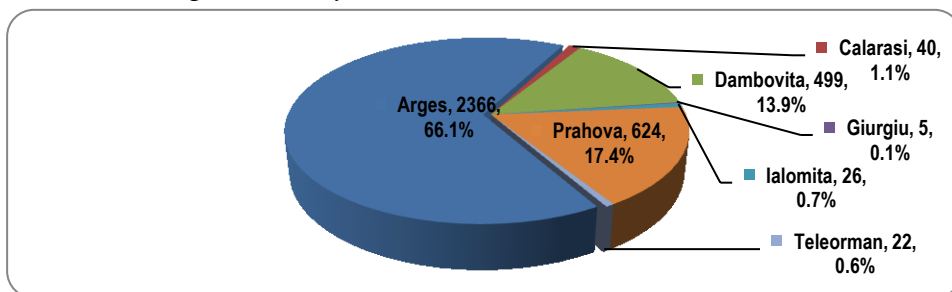

Source: *Own calculations based on:*

<https://statistici.insse.ro/shop/index.jsp?page=tempo3&lang=ro&ind=TUR101C>

Regarding the distribution of the number of beds in agrotouristic boarding houses by counties, in 2015 this generally respects the established tourist areas of the South-Muntenia development region:

- Argeş county: 2366 (66.1% of those approved);
- Călăraşi county: 40 (1.1% of those approved)
- Dâmboviţa county: 499 (13,9 % of those approved);
- Giurgiu county: 5 (0.1% of those approved);
- Ialomiţa county: 26 (0.7% of those approved)
- Prahova county: 624 (17.4% of those approved);
- Teleorman county: 22 (0.6% of those approved).

Rural tourist circulation

Tourist traveling in a region characterized by the following indicators: changes in the number of tourists, number of overnight stays and length of stay (Stănciulescu, Micu, 2009). Since the average growth index is greater than 100% we can appreciate that it was recorded a significant progress. The dynamics of tourist arrivals in agrotouristic boarding houses in the period of 2005-2015 recorded in 2015 a maximum of 348% compared to 2004, when it was recorded the lowest for the period. Between 2005-2015, in South-Muntenia development region, the arrivals in agro touristic boarding houses in rural areas have recorded an annual average of 34,704.36 arrivals, an increase of 34,704.36 positive environment arrivals, which represents a 11.8% relative yearly progress.

Chart 11. *The evolution of arrivals in agro-touristic boarding houses, 2005-2015*

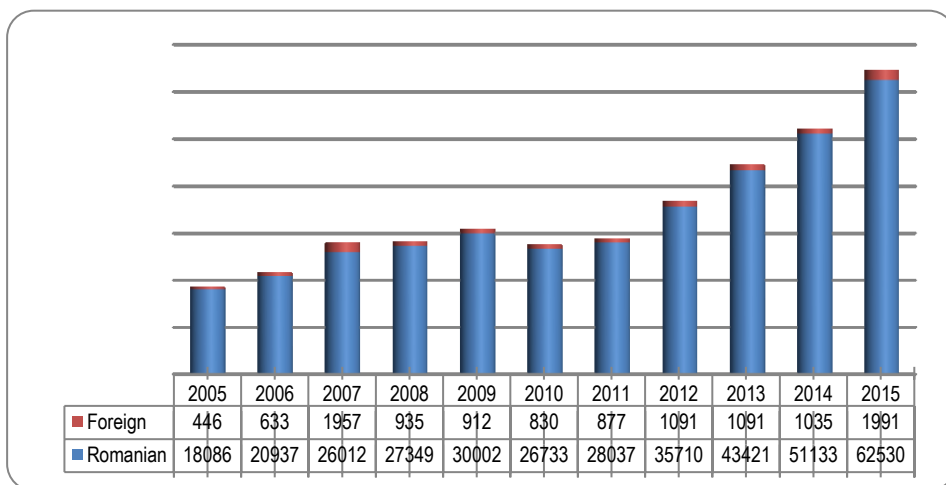

Source: *Own calculations based on:*

<https://statistici.insse.ro/shop/index.jsp?page=tempo3&lang=ro&ind=TUR103A>

Between 2005-2015 arrivals of tourists in rural areas ranged from 18,532 in 2005, to 27,563 in 2010 and to 64,521 in 2015. In the above Chart is illustrated the situation of tourist arrivals in agrotouristic boarding houses in the period 2005-2015. Noteworthy is the peak reached in 2015 when they recorded 64,521 tourist arrivals, which represents an additional 45,989 tourists compared to 2005. It can be observed that in the period reviewed the number of foreign tourist arrivals almost doubled (from 446 foreign tourists in 2005 to 1,991 in 2015). It is also significant the increasing number of domestic tourists who visited the South-Muntenia development region rural area. If in 2005 we recorded 18,086 arrivals of Romanian tourists the peak was achieved 10 years later, when official statistics recorded a total of 62,530 arrivals. Unfortunately for Romanian rural area, the number of foreign tourists that visit it is still a small one compared with that of domestic tourists (foreign tourists accounting for only 3.1% of the total arrivals in the countryside, remaining 96.9% were Romanian tourists). In terms of spatial distribution, flow receiver tourism experienced a strong focus, as it can be seen from the following charters. Most of the tourists visiting the countryside also turned their attention to the Argeş county (35,201 arrivals), Prahova county (13,545 arrivals) and Dâmboviţa (12,885 arrivals). Argeş county recorded in the year 2015, a total of 35,201 arrivals, which represents 56.3% of total arrivals in agrotouristic boarding houses.

Chart 12. *The evolution of arrivals in agrotouristic boarding houses, by counties, 2005-2015*

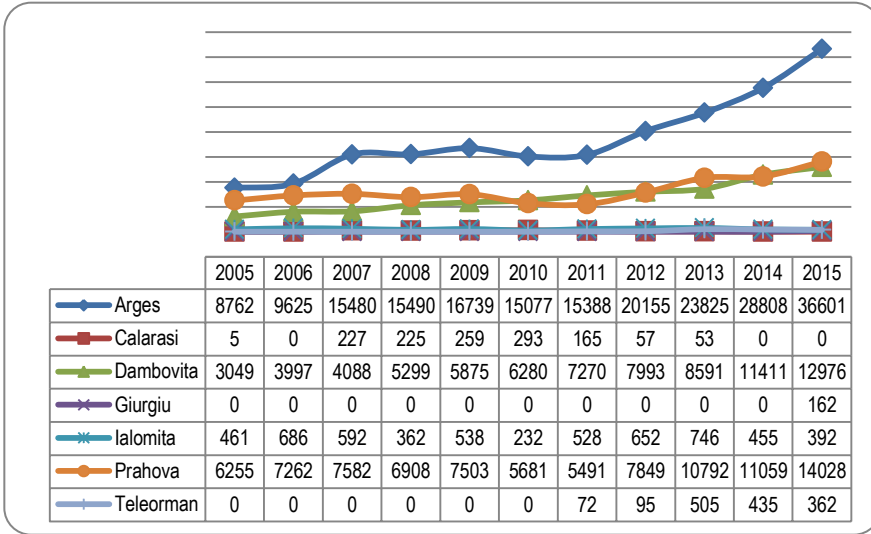

Source: *Own calculations based on:*

<https://statistici.insse.ro/shop/index.jsp?page=tempo3&lang=ro&ind=TUR103A>

Should be mentioned that are identified regional disparity between northern and southern of South-Muntenia development region. The analysis of data from the National Statistics Institute showed that three counties in the north (Argeş, Dâmboviţa and Prahova) together hold 98.6% of the total arrivals, while only four counties in southern region 1.4%, failing to capitalize on the tourism potential available (hunting and fishing).

Chart 13. *The share of arrivals in agrotouristic boarding houses, by counties, 2015*

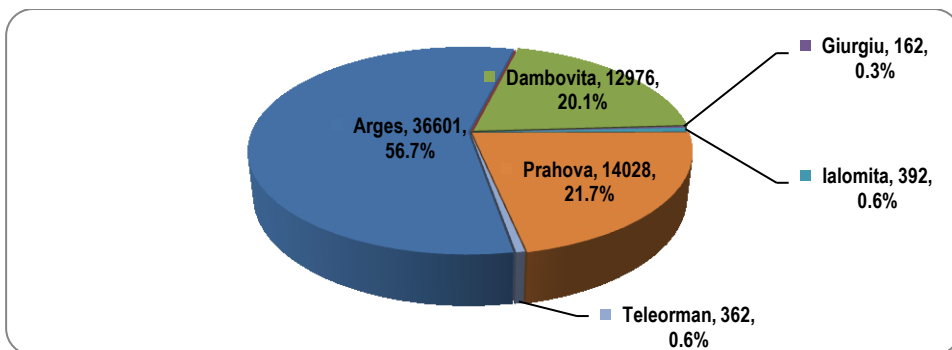

Source: *Own calculations based on:*

<https://statistici.insse.ro/shop/index.jsp?page=tempo3&lang=ro&ind=TUR103A>

Chart 14. *The evolution of Romanian tourist arrivals in agrotouristic boarding houses, by counties, 2005-2015*

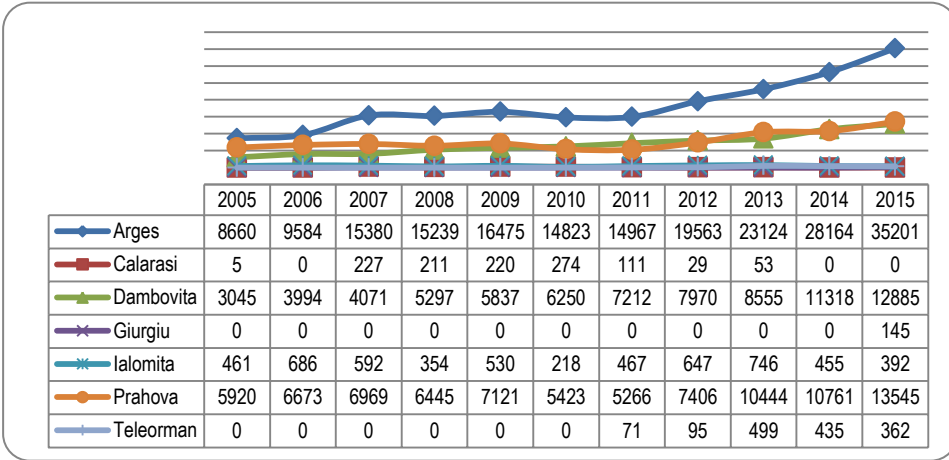

Source: *Own calculations based on:*

<https://statistici.insse.ro/shop/index.jsp?page=tempo3&lang=ro&ind=TUR103A>

According to the analysis of statistical data, most Romanian tourists arrived in agrotouristic boarding houses, in 2015 being recorded in the Argeş county (35,201) or 36.% of total domestic arrivals. Argeş county seconded by the Prahova county with 13,545 arrivals (22% of total Romanian tourist arrivals). Romanian significant increases in tourist arrivals recorded all 7 counties. For example, Dâmbovița county has increased by 423,15% and Prahova county increased by 228.8% in 2015 compared to the base year of the analysis, 2005 (see Chart no. ???).

Chart 15. *The share of Romanian arrivals in agrotouristic boarding houses, by counties, 2015.*

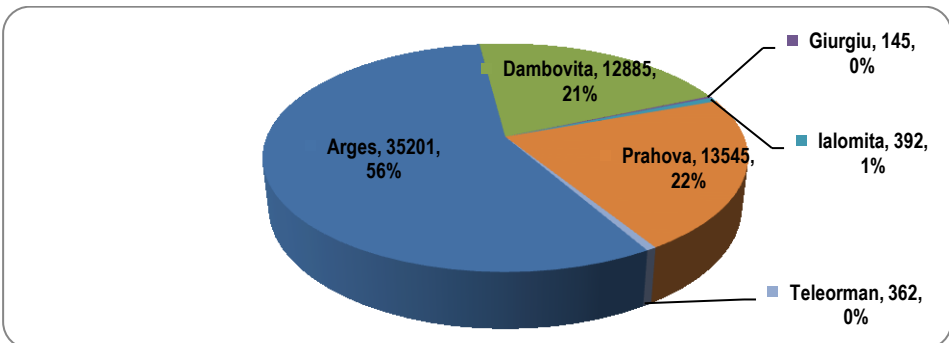

Source: *Own calculations based on:*

<https://statistici.insse.ro/shop/index.jsp?page=tempo3&lang=ro&ind=TUR103A>

Foreign tourists registered in agrotouristic boarding houses preferred the Argeş county. Over 70.3% of foreign tourists were attracted by the beauty of Argeş county village.

Nonetheless, we must not neglect the villagers' contribution who managed to preserve local traditions and customs. These are much better preserved compared to the rural areas from southern development region.

It is noticeable that the Romanian village is arousing great interest for foreigners, especially the villages of Argeş and Prahova Country, which together have managed to attract 94.7% of the total arrivals of foreign tourists in accommodation establishments by agrotouristic boarding houses. (See Chart no 15.)

Chart 16. *The evolution of foreign tourist arrivals in agrotouristic boarding houses, by counties, 2005-2015*

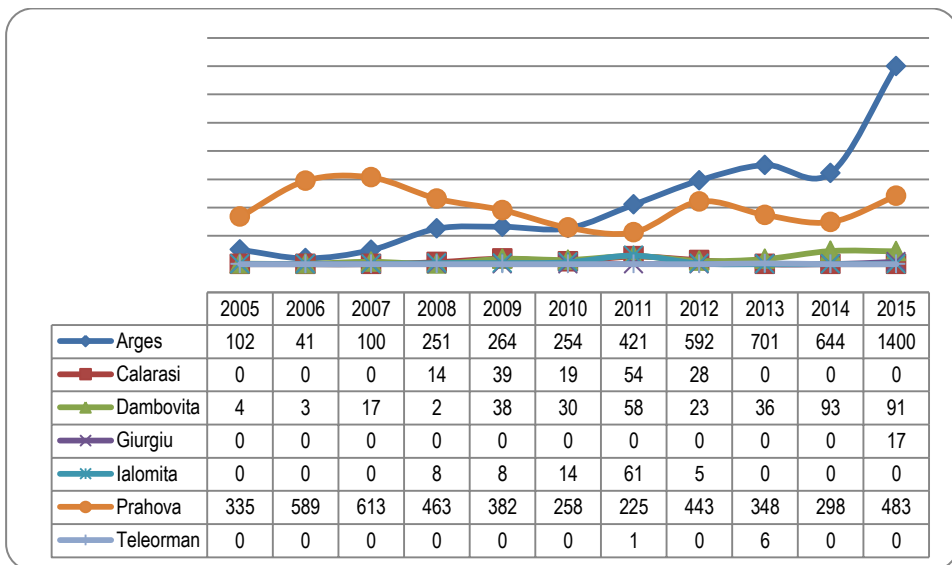

Source: *Own calculations based on:*

<https://statistici.insse.ro/shop/index.jsp?page=tempo3&lang=ro&ind=TUR103A>

According to statistics tracked for the period 2005-2015 it can be concluded that the number of foreign tourists who visited the Romanian village in the geographical area of South Muntenia development region has grown exponentially in Argeş (from 102 in 2005 to 1400 in 2015), Dambovita (from 4 in 2005 to 91 in 2015) (see chart No. 19)

Chart 17. *The share of foreign tourist arrivals in agrotouristic boarding houses, by counties, 2015*

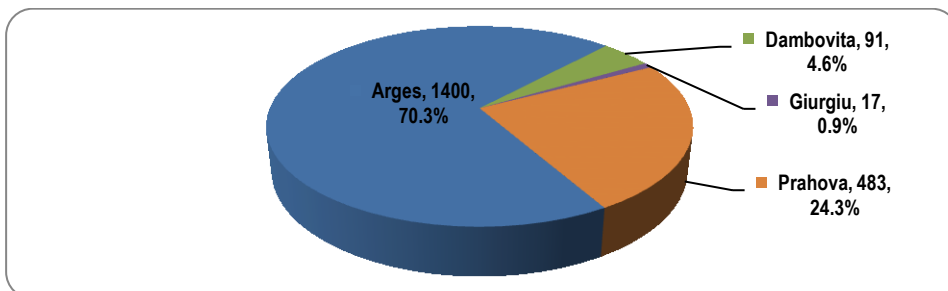

Source: *Own calculations based on:*

<https://statistici.insse.ro/shop/index.jsp?page=tempo3&lang=ro&ind=TUR103A>

The overnight stay is every night for one person is registered in a tourist accommodation, whether or not physically present in the room. The fact that tourist arrivals in accommodation and their overnight stays have increased steadily since 2005 is a positive factor for development of rural tourism in the region of South-Muntenia. For this trend to be maintained, we believe that it is necessary to modernize technical base material of rural tourism, accessibility in rural areas, to increase the quality of tourism services provided and not least to create service packages at attractive prices for all categories of tourists. Since the average growth index is greater than 100% appreciate that recorded significant progress. The dynamics of overnight stays in agrotouristic houses borders in the period 2005-2015 recorded in 2015 maximum 323% compared to 2005 when it was recorded and the lowest for the period.

Chart 18. *The evolution of overnight stays in agrotouristic boarding houses, between 2005-2015*

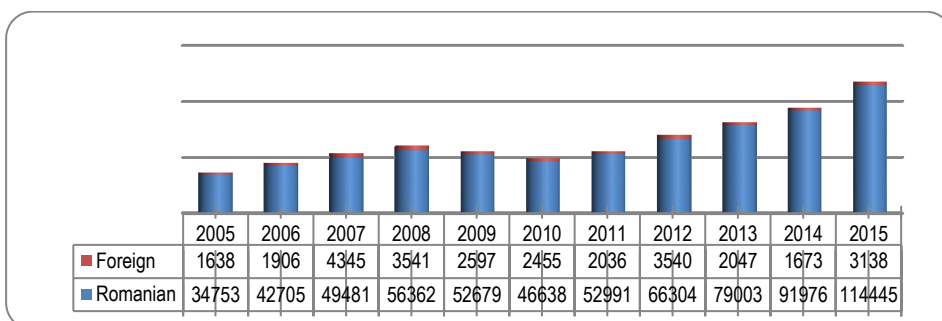

Source: *Own calculations based on:*

<https://statistici.insse.ro/shop/index.jsp?page=tempo3&lang=ro&ind=TUR103C>

In 2005-2015 the number of overnight stays in rural areas analyzed ranged between 36,391 in 2005, 49,093 in 2010 and 117,583 in 2015. In the chart above illustrates the situation in agrotouristic boarding houses overnight stays in 2005-2015. Noteworthy is the peak reached in 2015 when there were 117.583 overnight stays, which represents a plus of 81.198 overnight stays compared to 2005. In terms of number of nights spent by foreign tourists, it can be seen that in analyzed period it increased by 191.23% (from 1 638 nights spent by foreign tourists in 2005 to 3.138 in 2015). It is significant and increasing domestic tourists who spent the night in hostels and agrotourism. If in 2005 we recorded 34.753 overnight stays of Romanian tourists among their number peaked 10 years later, when official statistics recorded a total of 114 445 overnight stays.

Chart 19. *The evolution of overnight stays of tourists in touristic and agro touristic boarding house 2005-2015*

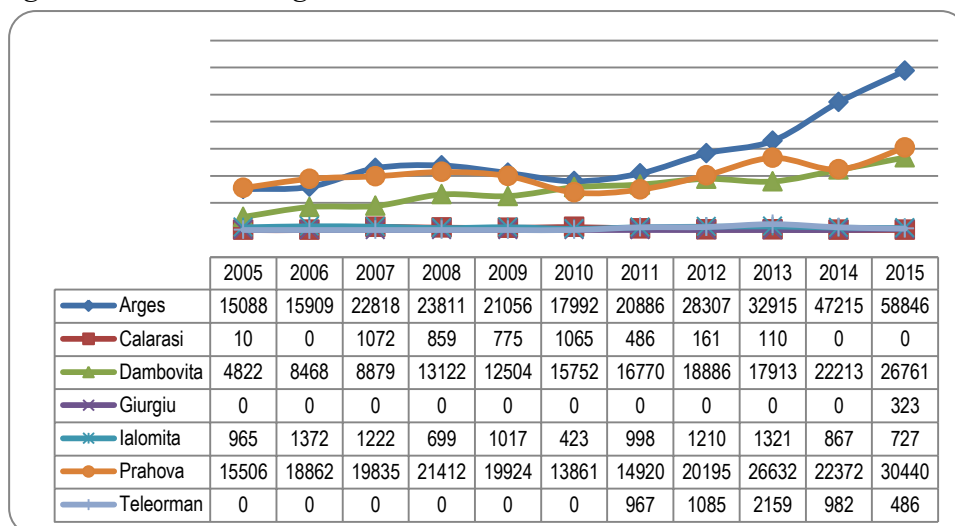

Source: *Own calculations based on:* <https://statistici.inse.ro/shop/index.jsp?page=tempo3&lang=ro&ind=TUR103C>

Unfortunately, the number of foreign tourists staying overnight in accommodation that specific rural area is still a small one compared with that of domestic tourists (foreign tourists accounting for only 2.67% of all overnight stays in rural areas, the remaining 97.33% were Romanian tourists). In terms of spatial distribution, flow receiver tourism experienced a strong focus, as can be seen from the charts next. Most of the tourists who spent the night in rural areas and have turned their

attention to the counties Arges, Prahova and Dambovita. These counties were recorded in 2015 a total of 116.047 overnight stays, which represents 98.69% of all overnight stays in the region's agrotouristic boarding houses South-Muntenia (see Chart 17).

Chart 20. *The share of overnight stays in agrotouristic boarding houses, between 2005-2015*

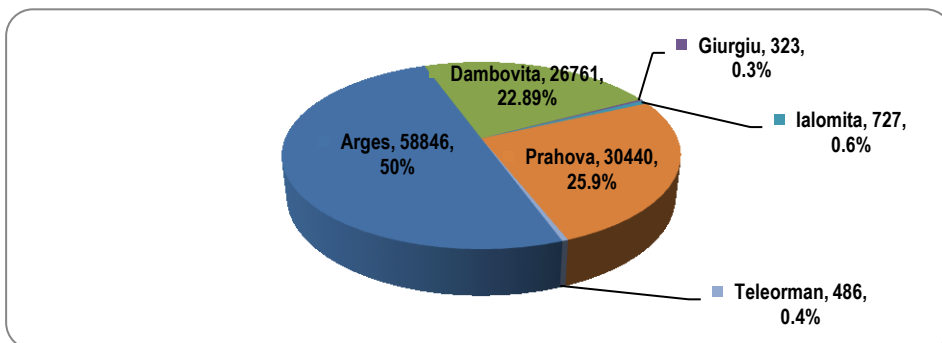

Source: *Own calculations based on:*

<https://statistici.insse.ro/shop/index.jsp?page=tempo3&lang=ro&ind=TUR103C>

The constant rise of overnight stays in agrotouristic boarding houses in all counties contemplated observation led to the 2015 share following counties:

- Argeș county: 58,846 (50% of the total overnight stays);
- Dâmbovița county: 26,671 (22.89 % of the total overnight stays);
- Giurgiu county: 323 (0.3% of the total overnight stays);
- Ialomița county: 727 (0.6% of the total overnight stays)
- Prahova county: 30,440 (25.9% of the total overnight stays);
- Teleorman county: 486 (0.4% of the total overnight stays).

Average length of stay

Regarding the average length of stay resulted that has remained constant since 2005. There were determining a series of statistical indicators, data analysis being extended for several years. It should be considered that the average length of stay could cast the number of days that remain in the tourist destination.

Tourist practice operates with an average length of stay, which is the ratio between the total number of tourists and overnight stays (based on total tourist accommodation capacity).

Table 5. *Average length of stays in agro-touristic boarding houses, 2005-2015*

Year	Lenth of stay	Length of stays for Romanian tourists	Length of stays for foreign tourists
2005	1.96	1.92	3.67
2006	2.07	2.04	3.01
2007	1.92	1.90	2.22
2008	2.12	2.06	3.79
2009	1.79	1.76	2.85
2010	1.78	1.74	2.96
2011	1.90	1.89	2.32
2012	1.90	1.86	3.24
2013	1.82	1.82	1.88
2014	1.80	1.80	1.62
2015	1.82	1.83	1.58

Source: *Author's own calculations based on*

<https://statistici.insse.ro/shop/index.jsp?page=tempo3&lang=ro&ind=TUR105C>,

<https://statistici.insse.ro/shop/index.jsp?page=tempo3&lang=ro&ind=TUR101B>

In agro-touristic boarding houses was a short duration of stay, below the national average. Characteristic of rural tourism is the duration of the stay small, not exceeding usually stay tourists staying in other tourist areas. According to the analysis, rural tourism, yielded values below the national average.

The average stay in the agrotouristic boarding houses were mixed, recorded in 2008 for the maximum period, of 2.12 days. Since 2008, the length of stay has declined steadily, recording the minimum in 2010, only 1.79 days. Analyzing the average length of stay of tourists compared to the Romanian foreign tourists can be seen for the period from the beginning of the review period greater value for foreign tourists. (Eg 1.92 days in 2005 for Romanian tourists, and 3.67 days for foreign tourists).

After the calculations became clear reversal of these values to the detriment of foreign tourists. For example, the average length of stay for foreign tourists decreased from 3.67 in 2005 to 1.58 days-only tourist in 2015 (see table 5 and the chart. 21).

Chart 21. *Evolution of the average length of stay in hostels agrotourism 2005-2015 Development Region South-Muntenia*

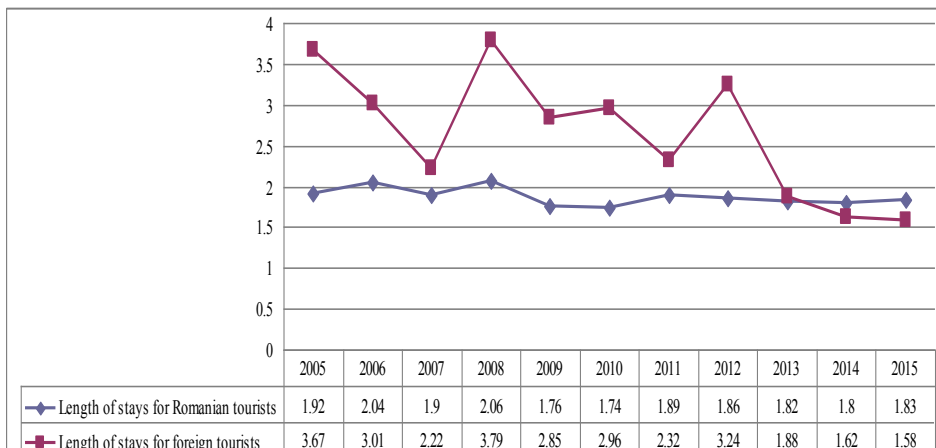

Source: *Own calculations based on:*

<https://statistici.insse.ro/shop/index.jsp?page=tempo3&lang=ro&ind=TUR105C>,

<https://statistici.insse.ro/shop/index.jsp?page=tempo3&lang=ro&ind=TUR101B>

Conclusions

Rural tourism may facilitate rediscovering the values of rural resources that have hitherto been disregarded in the modernization process of the world economy. It provides insights to both farmers and policymakers to adopt a wider perspective than to only focus on agricultural products. In this sense, rural tourism generally encompasses such holistic rural activities as agricultural production, lifestyle and rural amenities to attract people from both urban and rural areas. The main objective of the present paper is to determine status of the rural tourism in Romania. Rural tourism is considered to be a multi-dimensional activity essential to the local area not only rural areas in Romania, but all the nations of the world. However Romania has many potential in development of tourism especially rural tourism but development of rural tourism in Romania is still in its nascent stage. Romania has perfect opportunities to enhance its rural tourism. This paper showed a brief conception of rural tourism and its barriers in the rural areas of Romania. Agrotourism constitutes a major contributor to local development. Establishment and manning of hospices entails creation of new jobs. Development of agrotourism yields additional profits for the rural sector, and most of all, dissuades migration of rural population to cities and retains younger people in the countryside.

(Karagiannis, Stavroulakis, 2011). The expansion of rural tourism is a trend that is common to most countries in Europe. Tourism is considered to be a potentially complementary activity for local communities and especially for farming families. The benefits are generally summed up as a threeway yield for the host community (the economical and social dimension of rural tourism), for the land itself (environmental maintenance), and for the tourist (leisure and tourism in the countryside), which implies a sequence of inter-related benefits. (Canoves, Villarino, Priestley, Blanco, 2004)

For rural development in the South-Muntenia region must be ensured development of several economic sectors with potential untapped properly (agrotourism and services for counties in southern, livestock and entrepreneurship in relation to customs and traditional products – for counties in northern)

Although tourism infrastructure does not correspond - from the qualitative and quantitative point of view - to the requirements, it may be considered that there are some progresses in this domain, compared to previous years. As an alternative to mountain tourism in the north and for a comprehensive valorisation of the South Muntenia region, the investors and tourism authorities try to stimulate a greater interest for the southern part of the region by exploiting the potential of the area bordering the Danube. (Axinte, 2014). In the southern region there is potential to develop rural tourism, but unfortunately, as the above analysis, it became quite clear that is not used properly. It appears that the southern developed rural tourism where you can fish and hunt. Exemples of rural communities are: Arefu, Dâmbocioara, Corbeni (Argeş County), Belciugatele (Călăraşi County), Ogrezeni (Giurgiu County) and Giurgeni (Ialomiţa County). South Region differentiates itself from other regions by the diversity of relief, knowing lately agoturismului a rapid development, especially in Prahova Valley. Development of rural tourism has expanded to the other areas in the region, especially in hilly and mountains. Areas which potential agrotourism is based on the quality of the landscape, the natural benefits offered to tourists , but also on the specific gastronomic.

Tourism in rural areas has been actively promoted as a panacea for the economic problems of the rural population. However, research in various European countries has shown that rural tourism is not the solution for the problems facing the agricultural community, although it certainly can

contribute to diversify farm incomes in family farms, inject additional benefits into the rural economy, counteract emigration from rural areas, encourage an increase in cultural exchange between urban and rural areas, and enhance the values inherent to rural life, as well as contribute to the general diversification of the economy. (Canoves, Villarino, Priestley, Blanco, 2004).

Literature

1. Axinte, Ghe., *Objectives and means of action within the development strategy of the tourism South-Muntenia region*, http://feaa.ucv.ro/annals/v2_2014/0040v4-031.pdf, pp. 242.
2. Andrei, D.R.; Sandu, M.; Gogonea, R.M.; Chirișescu, V.; Kruzslıcica, M. (2012): *Modeling of rural tourism towards sustainable development from the perspective of specifically organic food*. Sci. Pap. Ser. Manag. Econ. Eng. Agric. Rural Dev., 12, pp. 21–28.
3. Barbieri, C., & Mahoney, E. (2009). *Why is diversification an attractive farm adjustment strategy? Insights from Texas farmers and ranchers*. Journal of Rural Studies, 25(1), pp. 58-66.
4. Busby, G., Rendle, S. (2000): *The transition from tourism on farms to farm tourism*, Tourism Management, Vol. 21(6), pp. 635-642
5. Căndea, M., Bran, F. (2001): *Spațiul geografic românesc. Organizare. Amenajare. Dezvoltare*, Economică, București, România.
6. Di Domenico, M., Miller, G., (2011): *Farming and tourism enterprise: Experiential authenticity in the diversification of independent small-scale family farming*“, Tourism Management, doi:10.1016/j.tourman.2011.03.007
7. Fleischer A, Pizam A. (1997): *Rural tourism in Israel*. Tourism Management; 18(6), pp. 367-372.

8. Fleischer A, Felsenstein D. (2000): *Support for small-scale rural tourism: Does it make a difference?* Annals of Tourism Research; 27(4):1007-1024.
9. Karagiannis, S., Stavroulakis, D., () *Development of Agrotourism through the Application of Internet Technologies: Problems and Perspectives*,
<http://citeseerx.ist.psu.edu/viewdoc/citations;jsessionid=C73551769EAB81528EB531E144DD09EF?doi=10.1.1.663.6098>
10. Canoves G., Villarino, M., Priestley, G., Blanco, A., (2004): *Rural tourism in Spain: an analysis of recent evolution*, Geoforum, Volume 35, Issue 6, November, pp. 755-769,
<http://www.sciencedirect.com/science/article/pii/S0016718504000454>
11. Lascăr, E., (2015): *The analysis of the economic development of South- Muntenia region*, Scientific Papers Series Management, Economic Engineering in Agriculture and Rural Development Vol. 15, Issue 1, pp. 256-257.
12. Zaharia, M., Ghiță, S., (2014): *Territorial Structural Changes of the Supply in Romanian Rural Tourism Accommodation*,
http://www.upg-bulletin-se.ro/archive/2014-1/7.Zaharia_Ghita.pdf, vol. III (LXVI), No1/2014, pp. 73.
13. Zaharia, M., Gogonea, M., Andrei, J., *The triunivocal relationship of rural tourism-Regional development-Sustainability*,
14. Nilsson, P. (2002): *Staying on farms: an ideological background*, Annals of Tourism Research, Vol. 29(1), pp. 7-24
15. Saxena, G., Clark, O., & Ilbery, B. (2007). *Conceptualizing integrated rural tourism*. *Tourism Geographies*, 9(4), pp. 347-370.

16. Sharpley, R. (2007). *Flagship attractions and sustainable rural tourism development: the case of the Alnwick Garden, England*. *Journal of Sustainable Tourism*,15(2), pp.125-143.
17. Veeck, G., Che, D., & Veeck, J. (2006). *America's changing farmscape: a study of agricultural tourism in Michigan*. *The Professional Geographer*, 58(3), pp. 235-248.
18. <https://statistici.insse.ro/shop/index.jsp?page=tempo3&lang=ro&ind=TUR103C>
19. <https://statistici.insse.ro/shop/index.jsp?page=tempo3&lang=ro&ind=TUR101C>
20. <https://statistici.insse.ro/shop/index.jsp?page=tempo3&lang=ro&ind=TUR101B>
21. <https://statistici.insse.ro/shop/index.jsp?page=tempo3&lang=ro&ind=TUR101A>

THE IMPORTANCE OF THE ICT FOR THE PURPOSE OF INCREASING COMPETITIVENESS OF RURAL AREAS

Jelena Matijašević-Obradović¹, Maja Kovačević²

Abstract

At the end of the last century, the concept of rural development gained significance both in the developed and in the developing countries, including Serbia. In the past few years, ICT have gained a very important role in rural development. Apart from the significance in the area of information and communication in rural areas, modern technologies have found a far wider application in rural development. After a short observation of the most important aspects of rural development and rural areas, the paper outlines the significance of ICT application for the purpose of increasing competitiveness of rural areas. Research in the paper includes priorities of sustainable rural development on the EU for the period of 2014-2020, and also the research studies for Serbia based on the data of Republican Bureau of Statistics regarding the use of ICT and SWOT analysis provided in the Agriculture and Rural Development Strategy for the period of 2014-2024.

Key words: *rural development, rural areas, ICT, competitiveness*

Introduction

Parts of a country's territory considered to be rural are those which have a relatively low density of population, but can also have/do have certain other specific characteristics in terms of natural, geographic and climate, as well as economy, society, etc.

Historically speaking, rural society evolved from a primitive rural community into the modern, particularly developed rural society. Scientific interest for rural society occurred in the late 19th century and

¹ Dr Jelena Matijašević-Obradović, associate professor, Faculty of Law for Commerce and Judiciary in Novi Sad, Geri Karolja 1, 021/400-499, loc. 22, jela_sup@yahoo.com

² Dr Maja Kovačević, assistant professor, Faculty of Economics and Engineering Management in Novi Sad, Cvecarska 2, majaskovacevic5@gmail.com

the beginning of the 20th century, when the village and the countryside community (lat. rus – field, village) began to be affected by global societal processes of industrialization, urbanization and modernization. A need arose to rationally understand and explain an entire set of societal processes and practical problems. In modern times, rural society is undergoing tumultuous changes accompanied by a significant difficulty to become incorporated in the dominant trends of modern society.³

At the end of the last century, the concept of rural development became more important even in the developed and the developing countries, including Serbia. The perspective on the politics of socioeconomic development changed drastically. The focus was placed not only on surpassing regional disparities and the differences between the urban and the rural development, but also on the coordination of the development of agriculture with other activities and services in rural areas in order to ensure better quality of life and improve life standard of the population by rationally utilizing resources and their preservation for the future generations. Today, this integral approach is the basis of all development policies of the EU countries, the membership of which Serbia strives for.⁴

In the past few years, information-communication technologies (ICT) have gained a very important role in rural development, primarily the Internet as the most significant and the most common global communication network. When mentioning ICT, particularly the Internet, the primary association refers to a series of positive effects brought upon by the expansive development of the technological aspect of modern society. Specially important is the shift in the area of receiving information and the communication itself in the rural parts. However, modern technologies have found a far wider application in rural development. Managing the environment, distance learning courses (particularly those connected to the lifelong learning approach), application in health, biotechnology, are only some of areas where the ICT expands its field of application on a daily basis. Strategic use of ICT helps to bring distant markets closer, to develop networks of knowledge and it aids in tackling the social exclusion of certain groups of the

³ Todorović, Marina (2007): *The rural society and rural geography in the past and the future*, Collection of papers No 57, Geographical Institute “Jovan Cvijic”, Sasa, pp. 45-53, p. 45

⁴ Đorđević Milošević Suzana, Milovanović Jelena (2012): *Sustainable Tourism for Rural Development - Small farms and rural tourism in Serbia*, Faculty of Applied Ecology Futura, University Singidunum, Belgrade Agroznanje, Vrsac FAO, Budapest, p. 21

population. For small businesses, ICT can often secure the necessary support for primary research, particularly while launching new products onto the market.⁵

In accordance with this, after a short observation of the significant aspects of rural development and rural areas, as well as models of diversification of rural economy, the paper will include a more detailed explanation regarding the significance of ICT application in modern society in general, and finally, the significance of ICT application for the purpose of increasing competitiveness of rural areas.

Rural development and methodology of determining rural areas

The introductory part stated that the basic indication that an area is in fact rural is a relatively low population density. Furthermore, any area is considered rural if it contains a series of specific features that can include certain natural, geographic and climate characteristics, economy, society, etc. At the beginning of the short observation of rural development, it is significant to primarily clearly define which geographic areas can be labeled as rural.

In accordance with the aforementioned, it is necessary to emphasize that “defining methodological and analytical frames for the scientific research and practical application of rural development basically comes down to several dimensions: regional (spatial), social, and agricultural. All three aspects of rural development are by definition and essence very complex, which is why defining universal developmental models and policies that would be acceptable for a larger number of regions or countries, is impossible.”⁶ One of the central problems is defining the generally accepted and standardized indicators for tracking the condition in rural

⁵ The project *Strengthening the dialogue between civil society in Serbia and the EU - Winging and coaching the civil society of Alibunar to approach the EU rural development*, part 4 - Application of new knowledge, skills and technologies in order to increase the competitiveness of products and services in rural areas, <http://www.leader.org.rs/> (15.09.2016.)

⁶ Bogdanov Natalija (2003): *Rural development - the EU's policy, state and perspectives in Serbia*, in the Proceedings of Agriculture and Rural Development in the European integration, economists Symposium on the 40th anniversary Agro segment, Faculty of Agriculture, University of Belgrade, Belgrade, pp. 82-92

areas.⁷ Once rural areas are defined, the rural indicators provide an image of their development according to a specific segment/s.⁸ This in fact means that development indicators of rural areas point to the most important aspects of development – the level of development, tendencies, variance, and other.

In understanding the rural region, from the initial to modern definitions valid today, a tendency to expand the term and give it more depth is evident. The final simple understanding of ruralness only in its territorial context has been surpassed by accepting the thesis that the rural region is a territorial entity with a coherent economic and social structure of diversified activities. This entity can include villages, small towns and regional centers. Even though the term “ruralness” is a direct association to specific characteristics of an area, these specific features cannot be used as criteria for defining ruralness. The criteria most often used in defining a rural area are population density and the number of inhabitants in a settlement. Apart from these indicators, other spatial/sector criteria are also used, such as the distance from the main roads, the presence of agrarian population and agrarian income, etc. Universal, generally accepted definition for distinguishing rural and urban types of settlements does not exist, but the countries choose the indicators for the classification of settlement types according to their own specific conditions and needs.⁹

OECD methodology provides the only internationally accepted definition of rural areas. However, two hierarchical levels of geographical units need to be distinguished: local communities and regions. By taking these two hierarchical levels as a starting point, the term rural is defined in two steps. First, local territorial units are defined as rural if their population density is below 150 inhabitants per square kilometer. Therefore, the criterion of classification on the level of regional units is population density, and the quantitative border is 150 inhabitants per square

⁷ Bogdanov Natalija, Stojanović Žaklina (2006): *The methodology of determining the identification of rurality and rural Serbia*, section in Agriculture and Rural Development of Serbia in the transition period, DAES and the Faculty of Agriculture, University of Belgrade, Belgrade, p. 4770, cit. prema: Bogdanov, Natalija (2007): *Small rural households in Serbia and the rural non-farm economy*, UNDP, Belgrade, p. 38

⁸ Stojiljković D., Bošković Olgica (2008): *Methodological notes relating to the identification of rural areas and by establishing indicators for measuring the degree of rurality*, *Agroekonomika*, no. 37-38, p. 48-56, Faculty of Agriculture, Novi Sad, p. 51

⁹ Bogdanov, Natalija (2007): op. cit., pp. 38-39

kilometer. The concept of population density is at the same time clear to its users and simple to calculate. Its advantage is that it is politically neutral, and that it does not refer to any specific perception of rural problems or potentials. Rural does not automatically mean: decreasing, poor, based on agriculture or peripheral. Second, regions are classified into one of the three types: pronouncedly (predominantly) rural area (if over 50% of the population lives in rural local communities), intermediate rural (mixed) area (if 15%-50% of the population lives in rural local communities) and pronouncedly (predominantly) urban area (if less than 15% of the population lives in rural local communities). Therefore, the criterion used to form the typology on a regional level is the share of the population of a region that lives in rural municipalities. In this manner, this typology reflects the degree of ruralness of the whole region. Apart from the main criterion (regional share of rural population), as of 2005, a secondary criterion is also used – the size of the urban center. If there is an urban center with over 200.000 inhabitants who do not comprise less than 25% of the population in the region, it is classified at least into the middle category of intermediate rural (mixed) region. If there is an urban center with over 500.000 inhabitants that do not comprise less than 25% of the population in the region, it is classified as predominantly urban region. Here, urban center is defined as a local unit (municipality) that has over 200.000 inhabitants and a population density over 150 inhabitants per square kilometer. A separate problem in the procedure of determining rural areas is the frequent change of borders between geographical units of the lower levels (frequently as a consequence of administrative reforms). Reclassification due to changes in population must also be frequently conducted. This makes the analysis of temporal series in this area extremely difficult, frequently even impossible.¹⁰ The European Union accepts the OECD definition of ruralness.

Rural regions of the EU and common agricultural policy

Around 57% of EU population lives in rural areas, which covers over 90% of the Union territory. The average population density spans from 38 inhabitants/km² in predominantly rural regions, to 125 in intermediate rural regions, to 614 in predominantly urban regions. In remote or sparsely populated areas, such as northern part of Finland, the population density can be even 2 inhabitants/km². Rural areas significantly differ based on the character: from suburban rural areas, to grasslands in high

¹⁰ Stojiljković D., Bošković Olgica (2008): op. cit, p. 49

mountains; from Mediterranean olive orchards to Portugal's vineyards, to grasslands in Lapland's tundra. Rural areas have a very rich and diverse regional and cultural heritage, and are an enormous reservoir of human skills and energy. Rural areas of Europe provide most of the food in Europe, lumber, etc. Rural economy of Europe is very diverse, as are the local communities that base their survival on it. Rural areas also provide a space for the recreation of European citizens and are a host to a growing number of tourists, both local and foreign.¹¹

Common agricultural policy (CAP) is one of the most significant policies of the EU. Bogdanov, N.¹² states that modern agricultural EU policy was shaped during several decades, in a region comprising of a group of countries with different tradition of agricultural sector, heterogeneous agrarian resources and differences in the importance of agriculture in the agricultural structure of member countries. Strategic choices, goals, mechanisms and measures of CAP have changed under the influence of European and world economic and political trends.¹³

The importance of CAP and rural development is increasing year by year, particularly with the new expansion of the European Union. The fact that CAP is so far the oldest, most carefully reformed sector common policy (Stresa Italy, 1958) should be particularly pointed out (from Mansholt's plan in 1968 to Fishler's reform in 2003), and that it is still the most financially demanding segment of economy in the European Union.¹⁴

The beginnings of the Common Agricultural Policy are tied to the Rome Treaty. By signing a contract on founding the European Economical Community (Treaty establishing the European Community) in Rome in 1957, the so called Rome Treaty, agriculture gained one of the central positions in the newly formed western European integration. In Article 39

¹¹ Dorđević Milošević Suzana, Milovanović Jelena (2012): op. cit., p. 25

¹² Bogdanov Natalija (2004): *The economy in international integration and the position of Serbia*, Monograph, Belgrade; cit. prema: Janković Snežana (2009): *The European Union and Rural Development of Serbia*, Institute for Science Application in Agriculture, Belgrade, p. 13

¹³ Janković Snežana (2009): op. cit.

¹⁴ Andrić Nataša, Tomić Danilo, Vlahović Branislav (2011): *Some aspects of the financing of Rural Development of the European Union*, Thematic proceedings "Agrarian and Rural Policy in Serbia - the necessity of speeding up reforms," Editors Danilo Tomic, Miladin M. Ševarlić, Stanislav Zekić, pp. 11-24, DAES - The Society of Agricultural Economists of Serbia, University of Novi Sad - Faculty of Economics, Belgrade, Novi Sad, pp. 11-12

of this contract, the goals of the Common Agricultural Policy have been defined: growth of productivity of agriculture, achieving a satisfactory life standard of the rural population, stabilization of the market of agricultural produce, ensuring a stable supply of food, supplying consumers at an affordable price.¹⁵

Today, CAP is a complex system of legal regulations, budget support and direct public interventions that are used to influence the situation in agriculture and rural environments. CAP system encompasses: import tariff, import quotas, intervention prices, and direct payment to the manufacturers. The importance of CAP is also seen in the EU budget allocations for its implementation. According to the financial perspective from the years 2007-2013, 43% of the total EU budget goes to rural development and implementing agricultural policy of the EU. The goal of common agricultural policy is to enable a solid living standard for the farmers, and affordable food prices for the consumers. Today, protection of the environment from the negative effect of agriculture, food quality, as well as price-quality ratio is of key position.¹⁶

According to Ristić L., in the past decades, there was a significant complementarity visible between agriculture, rural economy and sustainable rural development in the European Union (EU). Today, in the EU, in accordance with Strategy Europe 2020 – using “smart”, “sustainable” and “inclusive” development (based on knowledge and innovations, in accordance with long-term needs of society, by promoting economy that utilizes its resources more effectively, one that is more “green” and competitive, by promoting employment, social and territorial cohesion) and the goals of the Common Agricultural Policy of the EU are expected to result in new policy of rural development of the EU for the period of 2014-2020 which would contribute to: increasing the competitiveness of agriculture; sustainable use of natural resources; spatially balanced development of rural areas.¹⁷ Table 1 provides an overview and the description of the suggested priorities of sustainable rural development policy of EU, for the period of 2014-2020.

¹⁵ Janković Snežana (2009): op. cit., pp. 13-14

¹⁶ Ibid., pp. 14-15

¹⁷ Croatian Rural Development Network (Hrvatska mreža za ruralni razvoj – HMRR) (2012): *Rural development EU after 2013*, Zagreb, Republic of Croatia, p. 6; Cit. prema: Ristić Lela (2013): *Strategic management of sustainable rural development in the Republic of Serbia*, Economic Horizons, Vol XV, Issue 3, p. 229-243, Faculty of Economics, University of Kragujevac, p. 234

Table 1. *Priorities of sustainable rural development of EU, in the period of 2014-2020.*

PRIORITY	DESCRIPTION OF THE FOCUS AREAS
Fostering knowledge transfer in agriculture, forestry and rural areas.	Life-long learning, professional education, application of the results of scientific research
Enhancing the competitiveness of agriculture and sustainability of agro-economic households.	Restructuring agricultural households faced with certain difficulties, with solving the problem of age structure of the households.
Promoting food chain organization and better risk management in agriculture	A more adequate inclusion of primary manufacturers into the food chain, through promotion quality schemes, promotion in the local markets, manufacturer associations and inter-branch organization, as well as support in risk management.
Restoring, preserving and enhancing ecosystems dependent on agriculture and forestry.	Caring of biodiversity, waters and land.
Promoting resource efficiency and supporting a shift towards a low-carbon emission economy	Increasing the effectiveness of utilizing water and energy in agriculture and manufacturing industry, production and use of renewable energy sources, decreasing harmful gas emissions.
Promoting social inclusion, poverty reduction and economic development in rural areas	Economic diversification, local development promotion and information-communication technologies in rural areas.

Source: Ristić Lela (2013): *Strategic management of sustainable rural development in the Republic of Serbia*, Economic Horizons, Vol XV, Issue 3, 229-243, Faculty of Economics, University of Kragujevac, p. 235

Rural areas in Serbia

In order to enable a comparison with the statistical data of the EU, rural areas in Serbia have been defined according to OECD criteria as those municipalities that have population density below 150 inhabitants per square km. According to this definition, 130 out of 165 total municipalities are characterized as rural, with 3904 settlements. Using this definition, rural areas in Serbia cover 85% of the country's territory with over a half of the total number of inhabitants (55%), and population density of 63 inhabitants per km².¹⁸ Most of the natural resources of the country (agricultural farmland, forests, waters) with their rich ecosystems and biodiversity are located in rural areas. Human resources employed in various agricultural

¹⁸ Mirković, Miroslav (2010): *Integrated rural development as a factor in poverty reduction*, Ekonomski pogledi, pp. 45-54, no. 1, pp. 45-46

activities are a particularly important potential. Natural, cultural, and historical legacy is an important component of the rural sector.¹⁹ According to the Strategy Plan of Rural Development, Serbia's region has the highest tourism potential and the highest participation rate of tertiary sector in the economic structure, and it includes the following municipalities: Mali Zvornik, Krupanj, Osečina, Ljubovija, Bajina Bašta, Kosjerić, Užice, Čajetina, Priboj, Prijepolje, Nova Varoš, Ivanjica, Sjenica, Tutin, Novi Pazar, Raška, Brus i Aleksandrovac . In this region, the structure of the agriculture is rather undeveloped and is mostly based on utilizing natural resources, particularly with feeding of the livestock.²⁰ Neglecting rural regions in Serbia, bad infrastructure, economic and technological stagnancy, traditional poverty (income less than 2\$ per day), all condition the isolation of many villages, which has as a consequence abandonment and extinction of certain villages.²¹ Extremely negative demographic shifts are a characteristic of Serbian villages in the past few decades. Unfavorable tendencies are also recorded when it comes to the age of the population. According to the classification of the United Nations, our country is among the top ten countries in the world with the oldest population. About 58% of the rural population is over the age of 50, and 22.4% is over the age of 65.²²

Serbian village is characterized by an increasingly larger material poverty of the elderly that remain in the villages. Today, population is decreasing in 86% of Serbian villages, and only 12% records growth. Already, there are over 200 villages in Serbia without a single inhabitant younger than 20, and over half of the population in the country lives in villages. We have 1961 villages without a single inhabitant. A particular problem of migrations is that in most cases, the young and the educated leave villages and small environments and depart into larger city centers. In this manner, rural areas are left without workforce, but also without significant human capacities necessary for agricultural development and attracting investments.²³ Taking into consideration that rural areas take up about 85% of Serbia's territory, and that rural population comprises over half of the total population, a need is evident for further investment into these regions for the purpose of increasing the social and economic conditions, in the isolated rural areas that are faced

¹⁹ *The Plan of Rural Development Strategy, 2009-2013*, Republic of Serbia, Ministry of Agriculture, Forestry and Water Management, February 2009, p. 4

²⁰ *Ibid.*, p. 11

²¹ Mirković, Miroslav (2010): *op. cit.*, p. 46

²² Vujičić Milica (2008): *Tourism and agribusiness*, DUNP, Novi Pazar, p. 219; *cit. prema*: Mirković, Miroslav (2010): *op. cit.*, p. 46

²³ Mirković, Miroslav (2010): *op. cit.*, p. 46

with depopulation tendency, as well as in suburban areas. Investing into the development of rural economy and local communities is a vital factor for increasing the quality of life in rural environments by improving access to public services, building infrastructure and a more suitable business environment.²⁴ An area strategically important for investment and improvement in rural regions is the area of ICT application. Namely, ICT have gained a very important role in the rural development in the past few years, primarily the Internet as a basic and the most significant global communication network. ICT have multiple functions when it comes to the diversification of rural economy. They have a particularly important role in the field of information and communication in the rural areas. However, modern technologies have found a far wider application in rural development. Their application helps to bring distant markets closer, to develop networks of knowledge and annul the recent, almost certain social exclusion of particular groups of inhabitants.

The significance of ICT application in modern society

In the conditions of modern life and work, there are practically no fields where ICT, computers and computing networks are not applied. It could be said that in the work and business conditions today, ICT application is of vital importance. It enables simple and quick communication, almost instantaneous transfer of a large quantity of data to great distances, simple publishing and updating of documents in electronic form as well as their global availability, digital delivery of goods and services, direct payment using the Internet, creating virtual organizations, etc. Such manners of organization and realization of activities in the economic and the business sector are definitely used as the outline of diversification of rural economy. Therefore, ICT are the instigator and the carrier of economic development. The contribution of innovations lies in increasing production, export, and competitiveness of economy in its whole. The research conducted by Republican Bureau of Statistics regarding the use of ICT in companies indicates that 97.8% of the companies use a computer in doing business. Computers are represented 100% in large and medium sized companies, and 97% in small companies. In Belgrade, computers are represented 98.5%, while in central Serbia that percentage is smaller – 96.4%. The use of computers according to the type of

²⁴ Kostić Stanković Milica (2013): *Marketing ... and Rural Development ... and Tourism*, the Standing Conference of Towns and Municipalities - Association of Towns and Municipalities of Serbia, Belgrade, p. 6

business of the company, shows that they are most represented in banks and insurance companies, businesses dealing with real estate and traffic, storage and transportation.²⁵

According to Republican Bureau of Statistics research regarding the use of ICT in companies in the year 2015²⁶, the following results have been reached: 1.) 100% of companies in the territory of the Republic of Serbia use a computer in doing business; 2.) 99.1% have internet connection; 3.) 75.2% of businesses own a web-site, which is 1.2% increase compared to 2014 and 1.4% increase compared to 2013. Owning a website in business according to type of activity: information and communication (91.6%), administrative and assistance service activities, computer repair (90.7%), manufacturing industry (84.9%); accommodation and diet services (83.5%), real-estate business, expert, scientific and technical activities (80.1%); transportation and storage (75.6%); construction (66.6%), provision of electricity, gas, steam and water, maintaining wastewater (63.4%), wholesale and retail (61.2%). Companies that own a web-site, usually provide the following services using that web-site: description of goods or services, pricelist (95.1%); the possibility for the visitors to familiarize with the products (83.6%); web content is adapted to regular visitors (78.6%); 4.) During the year 2014, 40.3% of companies in the Republic of Serbia ordered products/services using the Internet; 5.) Social networks are ever more present even for the business of the companies. Research results, which indicate that as many as 28.6% of companies used some of the social networks for business needs, testify to this.²⁷ Therefore, in modern conditions of life and business, ICT is of vital importance. Reasons for that should be searched in the swift progress and expansion of ICT, under the influence of which the very basis of industrial society is changing.²⁸ Implementing new technologies and perfecting the existing ones, accompanied by improving human resources, affects the level of productivity. The shifts in the productivity in a society

²⁵ Ignjatijević Svetlana, Matijašević Jelena, Carić, Marko (2011): *Business conditions and business environment in the Republic of Serbia, with emphasis on the use of information and communication technology*, Proceedings of the international scientific and professional symposium INFOTEH@-JAHORINA 2011, Vol. 10, Ref. E-IV-6, p. 681-684, Faculty of Electrical Engineering, East Sarajevo, p. 683

²⁶ Studies were conducted using the methodology of Eurostat, on the territory of the Republic of Serbia. The survey of enterprises was conducted on a sample stratified by size and activity, by telephone. It covered 1361 company.

²⁷ Kovačević Miladin, Pavlović Kristina, Šutić Vladimir (2015): *The use of information and communication technologies in the Republic of Serbia - households / individuals, companies*, Serbian Republican Bureau of Statistics, Belgrade, pp. 78-86

²⁸ Devetaković, Stevan i sar. (2009): *National Economy*, Faculty of Economics, Belgrade, p. 206

are influenced by the shifts in the physical, human capital, natural resources, and technological knowledge.

ICT application for the purpose of increasing competitiveness of rural areas

Improving competitiveness of rural areas requires a promotion of sustainable development and the creation of new employment options, particularly for the younger population, as well as enabling access to modern ICT. Diversification of activities in rural areas to agricultural and non-agricultural activities, support to the non-agricultural activities and strengthening the connection between different spheres of rural development plays an important role in this.²⁹

According to the Agriculture and Rural Development Strategy of the Republic of Serbia for the period of 2014-2024 (hereinafter: Strategy)³⁰, rural areas of Serbia are characterized by diversity of landscapes and biodiversity, rich cultural heritage and natural resources. On the other hand, they suffer the consequences of demographic abandonment. That is the reason of their developmental delay, the presence of all kinds of deprivation and growing poverty. Their economy is reduced to exploitation, depletion and continuous degradation of natural resources, it is based on agriculture and the activities connected to it, with a limited offer of quality working positions and humble options of generating external income. The growth of attractiveness of rural areas as places for the life of young families is closely tied with improving physical infrastructure, better availability of social services, improving social structure, and supporting the development of entrepreneurship.

The lack of respect for the specific needs of the countryside and its inhabitants, the lack of systemic and better coordinated activities of various influential persons carries a serious threat for the increased growth of developmental divergence of rural areas and the cities. Significant chances for development, both for the agriculture and the rural environments, can be found in creating an efficient system of knowledge transfer, technology and information, as well as innovative ways of using the potential of the cultural heritage and biodiversity.

²⁹ Kostić Stanković Milica (2013): op. cit., p. 7

³⁰ "Official Gazette of the Republic of Serbia", no. 85/2014, p. 56

In the past few years, ICT have gained an important role in the rural development, primarily the Internet as the most significant global communication network. Especially significant is the shift in the field of information and the communication in rural areas themselves. However, modern technologies have found a far wider application in rural development. Managing the environment, distant learning courses (particularly those with lifelong learning approach), application in health, biotechnology, are only some of spheres of life where ICT application is continuously expanding.

The practice is abundant with examples showing the importance of ICT application (Swift and efficient cooperation between distant markets, developing a network of knowledge, social connection of certain groups of inhabitants, necessary support to small business, particularly with placing new products on the market...), while the strategic documents include ICT application as a significant segment of rural development. For example, following Tables will list a segment of SWOT results of the analysis of agriculture and rural areas provided in the Strategy, which indicates the significance of ICT application for the rural areas in Serbia.

Table 2. *SWOT analysis of strengths and weaknesses for the technological development and the environment in Serbia*

STRENGTHS	WEAKNESSES
Technological development and the environment	
Large number of scientific and educational institutions that could become a part of the knowledge creation and transfer system; Existence of interest in accepting new technologies (big households);	Low quality of equipment and technical conditions for research;
Relatively low level of agricultural pollution in the most areas in the country; Rich biodiversity and existence of genetic resources;	Lack of development institutions and demonstration facilities;
Significant areas of High natural value fields;	Relatively small number of beneficiaries of the organized knowledge transfer;
Significant biomass production, possibility of production of energy crops and usage of renewable energy sources.	Degradation of biodiversity, especially in the areas with limited conditions for agricultural production;
	Inadequate waste management system;
	Inadequate water management system.

Source: *Strategy, op. cit., p. 51-54*

Table 3. *SWOT analysis of strengths and weaknesses for the rural development in Serbia*

STRENGTHS	WEAKNESSES
Rural development	
Diverse and attractive rural ambient;	Unfavorable demographic trends;
Rich cultural heritage;	Inactive labor market;
Preserved traditional knowledge and technology;	Unfavorable social structure;
Existence of good practice in rural tourism and accompanying activities;	Unused possibilities for income diversification in households;
Launched activities for establishing local social networks;	Insufficient usage of cultural heritage;
Solid situation with infrastructure in some rural areas.	Low level equipment of the infrastructure;
	Impaired accessibility of social services;
	Low level of social capital.

Source: *Strategy, op. cit., p. 51-54*

Table 4. *SWOT analysis of the opportunities and threats for the technological development and the environment in Serbia*

OPPORTUNITIES	THREATS
Technological development and the environment	
Capacities for knowledge creation and transfer exist;	High costs of knowledge transfer;
There are underused possibilities for public-private partnerships in knowledge and technology creation and transfer;	Lack of coordination among the relevant ministries and low participation of the applicable projects in food production field;
Increasing needs for various types of consultancy services;	Insufficient innovation potential of scientific-research staff;
Possibility of production of bio-energy crops;	Lack of interest and motivation of producers to accept new knowledge and technologies;
Improved usage of thermal water in greenhouses;	Inadequate and insufficiently diversified offer of educational modules and practical trainings;
Improved usage of solar and wind energy.	Lack of systemic response to climate change.

Source: *Strategy, op. cit., p. 51-54.*

Table 5. *SWOT analysis of the opportunities and threats for the rural development in Serbia*

OPPORTUNITIES	THREATS
Rural development	
Possibility for creation of new products and services;	Rural specific characteristics haven't been adequately recognized in local and national policies;
Possibility for public-private partnerships;	Investors insufficiently interested;
Revitalization of the resources and social services in the areas with limited conditions for agricultural production;	Growing rural poverty and regional differences in poverty;
Possibility to intensify regional cross-border cooperation;	The specific characteristics of small households haven't been recognized in national policies, including the agricultural policy;
Usage of the pre-accession period to increase competitiveness, apply standards using the EU funds (IPARD);	Pause in the EU integration process;
Possibility to develop all kinds of tourism related to rural areas including the areas of high natural value.	Lack of capacities in the areas with limited conditions for agricultural production to use budget support.

Source: *Strategy, op. cit., p. 51-54.*

Conclusion

The development and the use of ICT have transformed the modern society into an “information society”. ICT play an important role, both in the production and the economy in in general, as well as in all other spheres of life of individuals and the society as a whole. Looking back at the goals of the Europe Strategy for 2020, and Common Agricultural Policy of the EU, we noticed that the priorities of rural development of the EU in the period of 2014–2020 include economic diversification, promotion of local development and ICT in rural areas, as well as lifelong learning, professional education, application of scientific research results. The basic aim of such defined EU priorities is to increase competitiveness of agriculture, sustainable use of natural resources, and spatially balanced development of rural areas. On the territory of Serbia, within the field of ICT, particularly important is the shift in the field of information and the communication within rural areas. However, modern technologies have found a far wider application in rural development. Based on SWOT analysis of the advantages and opportunities, as well as weaknesses and threats to the technological development and the environment, and the rural development

in Serbia given in the Agriculture and Rural Development Strategy of Serbia for the period of 2014-2024, following conclusions were drawn.

The advantages and the opportunities in the field of technological and rural development are definitively a large number of scientific and educational institutions that can be included in the system of creation and transfer of knowledge, the interest for accepting new technologies (big households), the existence of capacities for the creation and transfer of knowledge, the existence of unutilized possibilities for the creation of private-public partnerships in the creation and transfer of knowledge and technologies, the possibility of creating new products and services. The weaknesses and threats in the field of technological and rural development are the following: low equipment quality and technical research conditions, organized transfer of knowledge reaches a relatively small number of users, unutilized possibilities of income diversification in the household, high cost of creating and transfer of knowledge, insufficient innovative potential of scientific-research staff, disinterest, lack of motivation of the producers to accept new knowledge and technologies, inadequate and insufficiently diversified offer of educational modules and practical trainings. A strategic use of ICT is without a doubt of high importance for increasing competitiveness of rural areas. Valencia Declaration, from February of 2003 states the following: “Rural areas are a core European asset, which can reach their full potential by using new information and communication technologies (ICT) too increase the quality of life and work opportunities of the citizens in rural areas, to strengthen the development of the rural economy, both in the traditional and the new sectors, enabling rural areas to fully integrate and participate in the knowledge-based economy of Europe.”³¹

Literature

1. Andrić Nataša, Tomić Danilo, Vlahović Branislav (2011): *Some aspects of the financing of Rural Development of the European Union*, Thematic proceedings "Agrarian and Rural Policy in Serbia - the necessity of speeding up reforms," DAES, University of Novi Sad - Faculty of Economics, Belgrade - Novi Sad, pp. 11-24.
2. Agriculture and Rural Development Strategy of the Republic of Serbia for the period of 2014-2024, "Official Gazette of the Republic of Serbia", no. 85/2014.

³¹ The project *strengthening the dialogue between civil society in Serbia and the EU - Winging and coaching the civil society of Alibunar to approach the EU rural development*, op. cit.

3. Bogdanov Natalija (2003): *Rural development - the EU's policy, state and perspectives in Serbia*, Proceedings of Agriculture and Rural Development in the European integration, Symposium on the 40th anniversary Agro segment, Faculty of Agriculture, University of Belgrade, Belgrade, pp. 82-92.
4. Bogdanov, Natalija (2007): *Small rural households in Serbia and the rural non-farm economy*, UNDP, Belgrade
5. Devetaković, Stevan i sar. (2009): *National Economy*, Faculty of Economics, Belgrade
6. Đorđević Milošević Suzana, Milovanović Jelena (2012): *Sustainable Tourism for Rural Development - Small farms and rural tourism in Serbia*, Faculty of Applied Ecology Futura, University Singidunum, Belgrade Agroznanje, Vrsac FAO, Budapest
7. Ignjatijević Svetlana, Matijašević Jelena, Carić, Marko (2011): *Business conditions and business environment in the Republic of Serbia, with emphasis on the use of information and communication technology*, Proceedings of the symposium INFOTEH@-JAHORINA 2011, Vol. 10, Ref. E-IV-6, p. 681-684, Faculty of Electrical Engineering, East Sarajevo
8. Janković Snežana (2009): *The European Union and Rural Development of Serbia*, Institute for Science Application in Agriculture, Belgrade
9. Kostić Stanković Milica (2013): *Marketing ... and Rural Development ... and Tourism*, the Standing Conference of Towns and Municipalities - Association of Towns and Municipalities of Serbia, Belgrade
10. Kovačević Miladin, Pavlović Kristina, Šutić Vladimir (2015): *The use of information and communication technologies in the Republic of Serbia - households / individuals, companies*, Serbian Republican Bureau of Statistics, Belgrade, pp. 78-86
11. Mirković, Miroslav (2010): *Integrated rural development as a factor in poverty reduction*, Ekonomski pogledi, pp. 45-54, no. 1
12. Ristić Lela (2013): *Strategic management of sustainable rural development in the Republic of Serbia*, Economic Horizons, Vol XV, Issue 3, p. 229-243

13. Stojiljković D., Bošković Olgica (2008): *Methodological notes relating to the identification of rural areas and by establishing indicators for measuring the degree of rurality*, *Agroekonomika*, no. 37-38, p. 48-56
14. Todorović, Marina (2007): *The rural society and rural geography in the past and the future*, Collection of papers No 57, Geographical Institute "Jovan Cvijic", Sasa, pp. 45-53
15. *The Plan of Rural Development Strategy, 2009-2013* (2009): Republic of Serbia, Ministry of Agriculture, Forestry and Water Management
16. The project *Strengthening the dialogue between civil society in Serbia and the EU - Winging and coaching the civil society of Alibunar to approach the EU rural development*, part 4 - Application of new knowledge, skills and technologies in order to increase the competitiveness of products and services in rural areas, <http://www.leader.org.rs/>

INTERNET IN THE DEVELOPMENT OF RURAL TOURISM IN THE DANUBE RIVER BASIN IN SERBIA

Jelena Petrović¹, Snežana Milićević²

Abstract

The Danube river basin in Serbia is an area with a large number of villages, predominantly rural and intermediate rural areas and natural and cultural values, which represent extraordinary potential for the development of rural tourism. Despite this, rural tourism in the Danube river basin is underdeveloped due to lack of information on cultural and natural resources, organization of events, as well as farms and other accommodation facilities designed for tourists. The purpose of the paper is to analyze significant potentials for the development of rural tourism in the Danube river basin, including analysis of the level of development of rural municipalities and towns, analysis of natural and cultural resources, and analysis of availability of information about tourist offer on the Internet. The main goal of the work is to point to the significance of the Internet in the development of rural tourism in the Danube river basin.

Key words: *rural areas, rural tourism, the Internet, cultural resources, natural resources, the Danube river basin*

Introduction

Danube river basin in Serbia covers the area between 45°48'39" and 44°12'48" of north latitude and 18°51'9" and 22°40'18" of east longitude. It includes part of the Danube that flows through Serbia, from Bezdán to Timok confluence into Danube.

¹Jelena Petrović, Ph.D., Assistant Professor, University of Niš, Faculty of Science and Mathematics, Department of Geography, Višegradska 33, Niš 18000, Serbia, +381-18-533-015, jelena25@pmf.ni.ac.rs

²Snežana Milićević, Ph.D., Assistant Professor, University of Kragujevac, Faculty of Hotel Management and Tourism in Vrnjačka Banja, Vojvođanska 5A, Vrnjačka Banja 36210, Serbia, +381-36-515-00-24, snezana.milicevic@kg.ac.rs

Danube river basin in Serbia is not specified as a separate regional unit. There is a large number of interpretations of the concept and physical reach of the Danube region, from the territories of which the Danube is a natural border to much broader ones, related to the functional significance and gravitational influences (Đorđević, 1996). Due to specifics, significance, and size of the Danube river basin in Serbia, it is necessary to pay special attention to it, to ensure its economic, tourism, and social development.

Most municipalities and towns in the Danube region in Serbia record density that is below 100 inhabitants per one square kilometer (Statistical Office of the Republic of Serbia, 2015). Starting from this indicator and the OECD-Eurostat methodology (Eurostat, 2010; OECD, 1994, 1996, 2006), 17 of 25 municipalities and towns on the territory of the Danube region are classified as predominantly rural areas. Since density is not the sole and exclusive indicator of rurality of municipalities and towns, the paper will pay special attention to the calculation of a synthetic indicator based on individual indicators, using multiple-criteria decision method to analyze rural development of municipalities and towns in the Danube region in the Republic of Serbia.

The basic prerequisite for the development of rural tourism is a rural area. The attractiveness of rural areas is the starting point for the creation of tourist offer of rural tourism destination (Milićević, Podovac, Čavlin, 2015). Rural areas generate multiple benefits for the development of rural tourism. From this point of view, rural tourism revitalizes rural areas, decreases depopulation, and allows valuation of natural resources and cultural and historical richness of rural areas. At the same time, tourism development contributes to the preservation and protection of cultural heritage, as well as of natural and traditional values specific to a particular rural area. Rural tourism has been developing in a large number of countries in Central and Northern Europe since the nineteen-sixties, while Eastern Europe is still expected to develop rural tourism in the future (Sgroi, Trapani, Testa, Tudisca, 2014).

Danube river basin in Serbia has significant natural and cultural resources. Geological structure, relief, climate, hydrological and soil characteristics, as well as flora and fauna determine natural wealth of the Danube basin. Banks of the Danube in Serbia are dotted with a large number prehistoric, Roman, and medieval archaeological sites, monuments, fortresses, monasteries, and churches, as well as modern towns and municipalities. Danube basin, as a tourist destination, can

achieve a competitive advantage on domestic and foreign tourist market on the basis of authenticity and diversity of its area.

Beirne and Curry (1999) use their research results to point out that information about destinations that respondents find on the Internet have a positive influence on changing their perceptions about destinations, as well as on the decision when choosing destinations to be visited. On the other hand, if the amount of information about the destination on the Internet is insufficient, consumers can eliminate destination from their choice, especially if the available amount and form of information about other interesting destinations is sufficient. Availability of information about the Danube region as a rural tourism destination would influence change of tourists' perceptions about this destination and a decision when selecting destinations to be visited.

The purpose of this paper is to highlight the importance of the Internet in the development of tourism in rural municipalities in the Danube region. The main objectives of the work are:

- 1) Determine the level of development of rural municipalities and towns in the Danube region, i.e. starting from a synthetic indicator based on individual indicators of rural development, classify municipalities and towns in the Danube region into urban and rural areas;
- 2) Analyze natural and cultural values on the territory of the Danube region in order to point out opportunities for rural tourism development;
- 3) Emphasize importance and possibilities of the Internet use for stimulating the development of rural tourism in the Danube region.

Literature

According to Čikić and Jovanović (2015), the main characteristics of rural areas are:

- Relative low population and facility density in balance with the landscape;
- Economic use of space with the dominant purpose of agriculture, forestry, and animal husbandry;

- Specific way of life of residents, characterized by loyalty to small communities and specific relationship to the area;
- Identity and representation which strongly connote with peasant culture.

Roberts and Hall (2001) state the following main characteristics of rural areas: low population density, use of rural land, and traditional culture of rural areas. There are different types of rural tourists, or tourists who visit rural areas, and these characteristics confirm the main attractions of rural areas as tourist destinations. According to Sharpley and Sharpley (1997), the need for peace, tranquility, landscape, and natural values, as well as traditional culture and gastronomy, are the main motives for the visit to rural destinations.

Rural tourism is an important factor in the development and revitalization of rural areas (Milićević, Đorđević, 2015). It allows rural areas to protect natural resources and cultural and historical heritage. At the same time, it can reduce exodus of population from rural areas through the creation of opportunities for reducing unemployment and achieving social and economic development.

Rural tourism has recorded significant growth in recent years due to the increase of population in towns, which tend to "escape" from the urban way of life and want to connect with tradition and way of life in rural areas. It includes different types of activities based on the protection of cultural and natural environment of local communities, bringing a unique experience to tourists during their stay (Epler-Wood, 2002). Rural tourism refers to all types of tourists' activities in rural areas, including elements related to tradition, culture, and hospitality of inhabitants of rural areas. In this way, rural tourism can be expressed by visits to farms and rural households, consumption of agricultural products, and other activities that are directly associated with resources of rural areas (Brunori et al., 2009).

Accommodation is a key factor in the development of rural tourism, because rural accommodation is different from hotel accommodation. As an integral part of rural tourism product, accommodation causes the establishment and operation of a large number of entities related to any part of rural tourism product. In Europe, farms play a significant role in the development of rural tourism. In rural areas of East Germany, 80% of accommodation is located on farms engaged in agricultural production or farms converted into accommodation facilities. In African rural areas, there are commercial farms intended for tourists, as well as a wide range

of private accommodation facilities, including traditional huts (Gavrila-Paven, Bârsan, Lia-Dorica, 2015). Information and communication technology plays a critical role in the competitiveness of tourism organizations and destinations, as well as industry as a whole (UNWTO, 2001). Search engines and Internet speed have an impact on the number of tourists from around the globe who use techniques and technology for the planning and realization of their trips (Buhalis, Law, 2008).

In order to show the potential of the Internet as a means of attracting and retaining customers in tourism, it is necessary to look at the number of Internet users globally. Today, about 40% of the world population has Internet connection, while in 1995 less than 1% of the world population used the Internet. In the period from 1995 to 2013, the number of Internet users increased significantly, by as much as ten times (Internet live stats, 2016). Bearing in mind the fact that the Internet is an integral part of life today, especially in developed countries, and given its significant increase in developing countries, it is expected that implications it has on tourism are indispensable. Second place among Internet users belongs to those who are interested in tourism and travel (Oliver, Livermore, Sudweeks, 2009). In addition, the Internet enables service providers to quickly and timely respond to the needs and desires of consumers. In order to be able to do so, providers of different services or tourism product components quickly and easily connect through the Internet, thus creating a unique product for consumers. The possibilities of the Internet as a direct information and distribution channel are also related to the development of successful web presentations of both tourism companies and tourist destinations locally, nationally, and globally (Petrović, Ivanović, 2011).

Analysis of indicators of rural development of municipalities and towns on the territory of the Danube region

It is necessary to point out that population density does not stand for the sole and exclusive indicator of rurality of municipalities and towns. For this reason, it is necessary to make a selection of indicators of rurality, and, based on them, use the multiple-criteria decision-making methods to calculate the synthetic indicator that will allow for the analysis of rural development of observed municipalities and towns in the Danube region.

In the selection of indicators of rurality, the work relies on the classification of rural development indicators given in the European Commission Report, including the following groups: 1) social and econo-

mic indicators, 2) sectoral economic indicators, 3) environmental indicators, 4) quality of life indicators (European Commission, 2013).

Table 1. *The indicators of rural development*

	Population density	Population ageing index	Population dependency index	Economic structure	Share of farmers in working population	Number of inhabitants per 1 km ² of arable land	Number of telephone subscribers per 1000 inhabitants	Number of citizens per one physician
Grad Beograd	518	130.8	43.8	0.8	3.1	856	502	279
Apatin	74	152.9	46.1	6	14.7	142	376	824
Odžaci	70	161.9	45.6	10.7	16.2	99	391	672
Sombor	69	156.5	45.5	7.7	18.7	94	399	307
Kovin	45	122.80	45.9	7.1	16.1	43	318	405
Bela Crkva	48	131.20	33.9	10.6	49.7	161	320	526
Pančevo	161	127.00	42.9	2.4	7.3	206	393	375
Novi Sad	516	106.90	42	1.2	2.5	715	515	230
Bač	38	132.10	45.9	12.9	29.7	61	369	928
Bačka Palanka	92	137.40	45.4	5.2	16.6	123	372	752
Beočin	84	111.60	44.5	1.2	9.8	262	425	771
Sremski Karlovci	168	140.10	43.7	0.8	3.5	473	360	839
Indjija	122	136.10	45.1	2.5	13.3	157	338	579
Irig	46	168.00	48.1	1.4	31.9	70	404	457
Pećinci	40	116.30	46.8	4.1	34.2	68	325	632
Ruma	91	139.10	43.5	3.7	18	133	356	828
Stara Pazova	187	119.90	43.8	1.7	9.6	242	334	778
Kladovo	32	218.20	57	1.3	15.5	116	383	296
Majdanpek	19	159.20	43.7	1.3	15.1	254	310	356
Negotin	32	222.00	60.4	1.5	39.8	96	410	316
Požarevac	163	122.80	48.7	1	12.9	201	388	275
Veliko Gradište	49	177.80	53.7	1.3	66.5	86	322	706
Golubac	22	205.60	59.6	4.4	44.1	94	335	662
Kučevo	20	227.80	61.7	4	31.8	91	338	726
Smederevo	224	116.00	43.8	0.6	14.9	300	334	428

Source: *Republički zavod za statistiku, Opštine i regioni u Republici Srbiji, Beograd, 2015; Republički zavod za statistiku, Demografska statistika u Republici Srbiji, Beograd, 2014.*

Considering indicators within these groups, level of economic and social development of Serbia and the Danube basin, as well as information available on the website of the Statistical Office of the Republic of Serbia, the paper pays special attention to the following indicators of rural development: population density, population ageing index, population dependency index, share of agriculture in total employment, share of farmers in working population, number of inhabitants per 1 km² of arable land, number of telephone subscribers per 1000 inhabitants, and number of citizens per one physician.

About 70% of municipalities and towns in the Danube region record population density below the limit of 100 people per square kilometer. Therefore, as many as 17 of 25 municipalities and towns are classified as predominantly rural areas. Belgrade and Novi Sad record population density greater than 300 inhabitants per square kilometer, but, according to OECD-Eurostat methodology, they are predominantly urban areas. According to this methodology, areas that record population density of 100 to 300 inhabitants per square kilometer are called “intermediate regional” areas. In the Danube region, 6 of 25 municipalities can be classified as “intermediate regional” areas.

Ageing index represents the ratio of the number of elderly (60 and older) and young (0-19 years) population (Statistical Office of the Republic of Serbia, 2015). The highest ageing index is recorded in Kučevo, Negotin, and Kladovo, while the lowest in Novi Sad, although it is not favorable, because the ageing index whose value does not exceed 20 index points shows that the population is very young, and more than 40 index points that the population is very old (Statistical Office of the Republic of Serbia, 2014).

Index of functionally (dependent) population points to economic and social consequences of the ageing population. The observed indicator shows the extent to which non-working part of the population depends on the working part of the population. Rural areas, compared to urban areas, record higher index of dependency due to a large number of elderly people. In terms of this indicator, the most unfavorable situation is found in municipalities with the lowest population density.

Rural areas record higher percentage of employees in agriculture compared to urban areas. This indicator is the highest in Bač, Odžaci, and Bela Crkva. The share of individual farmers in the working part of the population shows which part of the population is oriented towards

agricultural production. The highest value of this indicator is recorded in Veliko Gradište and Bela Crkva.

The number of inhabitants per square kilometer of arable land is an indicator with apparent agricultural capacities. The degree of rurality is greater at a smaller number of inhabitants per square kilometer of arable land. The number of telephone subscribers is an indicator that expresses the degree of development of communication. Urban areas are characterized by greater number of telephone subscribers in relation to rural areas. Number of citizens per one physician is an indicator of the level of health care for the population. If the index value is higher, situation with regard to health care is more unfavorable.

Multi-criteria compromise ranking method (VIKOR)

The starting point for the implementation of VIKOR method is to determine the initial decision matrix.

$$R = \begin{matrix} & f_1 & f_2 & f_3 \\ & w_1 & w_2 & w_3 \\ A_1 & [f_{11} & \dots & f_{1m}] \\ \vdots & \vdots & \ddots & \vdots \\ A_n & [f_{n1} & \dots & f_{nm}] \end{matrix} \quad \text{a)}$$

The best and worst values of f_j^* i f_j^- are determined for each criterion respectively. The lowest value is the best for the criteria that request the minimum value, and the highest value is the worst. For the criteria that request maximum value, the situation is reserved, so the highest value is the best, and the lowest value is the worst. Values d_{ij} , defined as:

$$d_{ij} = \frac{f_j^* - f_{ij}}{f_j^* - f_j^-} \quad (1)$$

are introduced for determining the values of S_i and R_i , followed by the calculation of pessimistic solution (S_i) and expected solution (R_i) (Opricović, 2009) using the formulas:

$$S_i = \sum_{j=1}^n w_j \frac{f_j^* - f_{ij}}{f_j^* - f_j^-} = \sum_{j=1}^n w_j d_{ij} \quad i = 1, 2, \dots, m$$

$$R_i = \max_j w_j d_{ij} \quad i = 1, 2, \dots, m \quad (2)$$

After calculating these values, their weight ν is determined, and each decision-maker chooses the values to be given. Thereafter, values of S^* and S^- and R^* and R^- are determined as follows:

$$\begin{aligned} S^* &= \min_i S_i, & R^* &= \min_i R_i \\ S^- &= \max_i S_i, & R^- &= \max_i R_i \end{aligned} \quad (3)$$

The values of QS_i , QR_i , and Q_i (compromise solution) are calculated for each alternative, forming three independent rankings.

$$\begin{aligned} QS_i &= \frac{S_i - S^*}{S^- - S^*} \cdot QR_i = \frac{R_i - R^*}{R^- - R^*} \\ Q_i &= \nu \cdot QS_i + (1 - \nu) \cdot QR_i \end{aligned} \quad (4)$$

Here ν is the weight of maximum group utility, and $1 - \nu$ is the weight of the individual regret (Opricović, Tzeng, 2007). Selecting the values of ν (weight to satisfy the most criteria) may favor the impact of the value QS_i or QR_i in the compromise ranking Q_i (Nikolić et al., 2010).

Alternative A_i is better than alternative A_k (according to all criteria) if $Q_i < Q_k$. The authoritative ranking is the compromise ranking Q_i for value $\nu = 0.5$. The best alternative is the one which has the lowest value Q_i and is in the first place in the compromise ranking.

However, if the first alternative in the compromise ranking does not meet the conditions U_1 (“sufficient advantage”) and U_2 (“sufficiently stable” position), then it is considered that it is not better than the other position alternative.

Condition U_1 – “sufficient advantage”

Alternative A_1 , which is in the first place in the compromise ranking Q_i for $\nu = 0.5$, has “sufficient advantage” over the following alternative A_2 if (Liu, Wang, 2011) $Q(A_2) - Q(A_1) \geq DQ$, where DQ is the threshold of “sufficient advantage” and amounts to: $DQ = \min(0.25; \frac{1}{m-1})$, whereby 0.25 is the threshold of “sufficient advantage” that limits the threshold for cases with a small number of alternatives.

Condition U_2 – “sufficient stability”

Alternative A_I must be the best in the ranking QS_i and/or QR_i . It must have “sufficiently stable” first position when changing the weight v . That is, it must meet at least one of the following three conditions:

1. To be the first in the rankings QS_i ,
2. To be the first in the rankings QR_i ,
3. To be the first in the rankings Q_i for $v= 0.25$ and $v= 0.75$.

If one of the conditions (U_1 or U_2) is not met, then a set of compromise solutions is made of:

1. Alternative A_1 and A_2 , if the condition U_2 is not met;
2. Alternative A_1, A_2, \dots, A_k , if the condition U_1 is not met; A_k is determined by relation $Q(A_2) - Q(A_1) < DQ$ for maximum k .

Finally, the results of VIKOR method can be explained on the basis of:

1. Ranking according to measures QS_i , QR_i , and Q_i ;
2. A set of compromise solutions (in the case that the conditions U_1 and U_2 are not met).

The results obtained using the above-mentioned methods are the basis for decision-making and acceptance of multiple-criteria optimal solution.

ENTROPY method

Determination of objective weight criteria according to ENTROPY method is based on measuring indeterminacy of information contained in the decision-making matrix. The method directly generates a set of weight criteria based on mutual contrast between individual values of alternatives for each criterion in particular, and for all criteria (Shannon, Weaver, 1947). Determination of weight criteria is implemented through three steps. In the first step, normalization of criterion values of alternatives is performed in the following manner:

$$r_{ij} = \frac{a_{ij}}{\sum_{i=1}^n a_{ij}} \quad (5)$$

Based on the previous formula, the initial decision matrix transforms into normalized decision matrix:

$$R = \begin{matrix} & c_1 & \dots & c_j & \dots & c_n \\ A_1 & \left[\begin{matrix} r_{11} & \dots & r_{1j} & \dots & r_{1n} \\ \vdots & \ddots & \vdots & \ddots & \vdots \\ r_{i1} & \dots & r_{ij} & \dots & r_{in} \\ \vdots & \ddots & \vdots & \ddots & \vdots \\ A_m & \left[\begin{matrix} r_{m1} & \dots & r_{mj} & \dots & r_{mn} \end{matrix} \right] \end{matrix} \right. \end{matrix} \quad \text{b)}$$

The amount of information contained in the normalized decision matrix represents the value of entropy e_j , which can be calculated as follows:

$$e_j = -k \sum_{i=1}^n r_{ij} \ln r_{ij} \quad e_j = -k \sum_{i=1}^n r_{ij} \ln r_{ij} \quad (6)$$

Introduction of the constant $k = 1/\ln n$ allows for all values of e_j to be in interval $[0, 1]$.

In the second step, the degree of divergence is determined in the following manner:

$$d_j = 1 - e_j \quad (7)$$

In the third step, starting from the value of d_j , values of weight criteria are calculated by simple additive normalization:

$$w_j = \frac{d_j}{\sum_{j=1}^m d_j} \quad (8)$$

Analysis and discussion of results

In Table 2, there are weight coefficients, calculated by using ENTROPY method, and the maximum or the minimum requirement for each criterion.

Table 2. *Weight coefficients for each criterion*

	f ₁ min	f ₂ max	f ₃ max	f ₄ max	f ₅ min	f ₆ max	f ₇ min	f ₈ max
Weight coefficients	0.297	0.017	0.006	0.240	0.221	0.162	0.006	0.051

Source: *Authors' calculation in Excel*

According to equation (1), starting from the values given in Table 1, the value d_{ij} is calculated by all criteria. Starting from the values of d_{ij} and weight coefficients (Table 2), using equations (2), (3), and (4), three rankings are formed, given in Table 3. According to the criteria QS_i , QR_i , and Q_i ($v=0.5$), the highest level of rural development is recorded in a_6 , i.e. Bela Crkva.

Table 3. Ranking of municipalities and towns on the territory of the Danube region

	QS_i	QR_i	Q_i ($v=0,5$)	Q_i ($v=0,25$)	Q_i ($v=0,75$)	Rang	Klaster
Bela Crkva (a_6)	0.0678	0.0000	0.0339	0.0169	0.0508	1	1
Bač (a_9)	0.0001	0.1914	0.0957	0.1436	0.0479	2	2
Odžaci (a_3)	0.1420	0.3269	0.2345	0.2807	0.1883	3	3
Sombor (a_4)	0.2329	0.3018	0.2674	0.2846	0.2502	4	
Kovin (a_5)	0.2158	0.3279	0.2718	0.2999	0.2438	5	
Apatin (a_2)	0.2577	0.3559	0.3068	0.3314	0.2823	7	4
Golubac (a_{23})	0.1564	0.4798	0.3181	0.3989	0.2372	6	
Kučevo (a_{24})	0.1899	0.5107	0.3503	0.4305	0.2701	8	5
Bačka Palanka (a_{10})	0.2855	0.4179	0.3517	0.3848	0.3186	9	
Pećinci (a_{15})	0.2168	0.5030	0.3599	0.4314	0.2883	10	
Ruma (a_{16})	0.3112	0.5340	0.4226	0.4783	0.3669	11	6
Veliko Gradište (a_{22})	0.1789	0.7197	0.4493	0.5845	0.3141	12	
Negotin (a_{20})	0.2718	0.7042	0.4880	0.5961	0.3799	13	7
Irig (a_{14})	0.2986	0.7120	0.5053	0.6086	0.4020	14	
Indija (a_{13})	0.4022	0.6268	0.5145	0.5707	0.4584	15	
Kladovo (a_{18})	0.3567	0.7197	0.5382	0.6290	0.4475	16	8
Majdanpek (a_{19})	0.3981	0.7197	0.5589	0.6393	0.4785	17	
Pančevo (a_7)	0.4861	0.6346	0.5604	0.5975	0.5233	18	
Beočin (a_{11})	0.4398	0.7275	0.5836	0.6556	0.5117	19	9
Stara Pazova (a_{17})	0.4893	0.6888	0.5890	0.6389	0.5392	20	
Požarevac (a_{21})	0.5089	0.7429	0.6259	0.6844	0.5674	21	10
Sremski Karlovci (a_{12})	0.5803	0.7584	0.6694	0.7139	0.6248	22	11
Smederevo (a_{25})	0.5733	0.7739	0.6736	0.7237	0.6234	23	
Novi Sad (a_8)	0.9556	0.9953	0.9754	0.9854	0.9655	24	12
Grad Beograd (a_1)	1.0000	1.0000	1.0000	1.0000	1.0000	25	

Source: Authors' calculation in Excel

Testing condition U_1 : Condition U_1 is fulfilled because

$$Q(a_9)-Q(a_6)=0.0957-0.0339=0.0618>0.042$$

$$DQ=\min\left(0.25, \frac{1}{25-1}\right)=0.042$$

Testing condition U₂: Condition U₂ is fulfilled because the area a₁ has „sufficiently“ stable first place according to three criteria:

1. Municipality a₆ has the first position in the rankings according to QS_i ,
2. Municipality a₆ has the first position in the rankings according to QR_i ,
3. Municipality a₆ has the first position in the rankings according to Q_i for $\nu=0.25$, $\nu=0.5$, and $\nu=0.75$.

Municipality a₆ has “sufficient advantage” in relation to the municipality a₉, which is in the second place in the rankings.

According to the criteria QS_i , QR_i and Q_i ($\nu=0.5$), the municipality of Bač is in the second place. According to the conditions U₁ and U₂, the municipality of Bač has “sufficient” advantage over the municipality of Odžaci.

According to the criteria QS_i , QR_i i Q_i ($\nu=0.5$), the municipality of Odžaci is in the third place. According to the conditions U₁ and U₂, the municipality of Odžaci has no “sufficient” advantage over Sombor municipality and the municipality of Kovin, so Sombor municipality and the municipality of Kovin enter into a set of compromise solutions, i.e. municipalities of Odžaci, Sombor, and Kovin belong to the third cluster.

The highest level of rural development is recorded in the municipalities of Bela Crkva, Bač, Odžaci, Sombor, Kovin, Apatin, and Golubac. The highest level of urban development is achieved in Belgrade, Novi Sad, Smederevo, and Sremski Karlovci. About 48% of municipalities in the area of the Danube region represent predominantly rural areas, while 36% of municipalities are intermediate rural areas, and 16% of municipalities and towns are predominantly urban areas.

Analysis of natural and cultural values in the area of the Danube region

In addition to the dominance of rural areas in the Danube region, its special value belongs to natural and cultural resources. Danube river basin in Serbia has significant natural values, because on its territory there are 2 national parks, 4 nature parks, 13 nature reserves, and 69 nature monuments. The total area of protected areas belonging to the Danube region is 163514 hectares (Registry of Protected Natural Resources, 2012). Most of these protected areas are located on the territory of Vojvodina, and

belong to the upper and middle Danube region, characterized by an authentic environment and a variety of flora and fauna.

Unlike the upper and middle Danube basin, the lower Danube basin is rich in cultural monuments from different historical periods. It should be emphasized that the area of the lower Danube region includes Đerdap gorge, the largest and most attractive river gorge in Europe.

Cultural and historical resources in the area of the Danube region are multiple and varied. On the banks of the Danube in Serbia there are important historical traces of ancient Rome, from the Middle Ages, the period of the Ottoman Empire, and the Austro-Hungarian monarchy. A continuous series of buildings with cultural and historical values in riverbank zones can be traced from Bač to Kladovo. Along the riverbank there are archaeological sites, the remains of Roman forts and towns, and fortresses.

In the area of the Danube region in Serbia, there are 7 fortresses; going downstream from Bačka to Đerdap, there are Fort Bač, Petrovaradin Fortress, Belgrade Fortress, Smederevo Fortress, Fortress Golubac, Ram near Veliko Gradište, and Fetislam near Kladovo. These are located in strategically important and prominent places, but also inaccessible places because their original purpose was to guard the border between the empires, which was for centuries along the banks of the Danube. When the Danube lost its border river status, the listed fortresses lost their original purpose and importance over time. Fortresses on the Danube represent significant cultural and historical monuments in Serbia, and an integral part of the European cultural heritage. The cultural-historical and natural resources, which are abundant along the banks of the Danube, represent an exceptional potential for development of rural tourism in this area.

Farms located in the area of the upper Danube region, which are one of the key elements for the development of rural tourism, are also worth mentioning. A number of tourism events and tourist activities, organized in rural areas in the area of the upper and middle Danube region, are an integral part of rural tourism offer.

Tourism potential in Serbia, as well as in the Danube region, is not sufficiently valued, because tourism has not had an important place in the development policy of Serbia (Bratić, Petrović, Živković, 2011). Adoption and implementation of development and tourism policies, as

well as cooperation between the public and private sectors, would contribute to the significant development of rural tourism in the area of the Danube region.

The role of the Internet in rural tourism development in the Danube region

Internet is an important source of information on natural and cultural resources of tourist destinations. At the same time, it represents an important means to promote tourist offer, but also a means of distribution of services on domestic and international tourism market. It enables direct communication between users and providers of tourist services. In order to survive on the competitive tourism market, tourist destinations and operators of the tourism industry are continually adapting to modern trends. They use the Internet as a platform for positioning tourist destination in order to improve the development of tourism. Promotion of modern tourism destination and its offer is based on online communication channels. Travel destinations create portals that use text, images, sound, animation, and interactive content to provide significant information to existing and potential tourists. The basis of e-marketing lies in multilingual websites of tourist destinations that allow visitors to get information about tourist destination and its entities, to perform online booking of accommodation, to review the calendar of events in the tourist destination, to communicate via e-mail with tourist offer entities, and to share personal experience about satisfaction with tourist services after the visit.

Website <http://www.danube.travel/main-menu/danubetravel.1.html> contains information on the Danube region in Europe as a tourist destination in English and German. The said site contains information about cultural and natural resources in the area of the Danube region, accommodation facilities, and events, as well as a brochure in Serbian. The website has information on accommodation facilities such as hotels, hostels, apartments, boarding houses, villas, camps, and other forms of private accommodation. It is very important that the site allows direct contact between potential users of accommodation services and service providers in order to obtain additional information and carry out online booking. When it comes to information about cultural and natural resources in the Danube region in Serbia, only Trajan's Plaque and Fruška Gora are mentioned. It is essential that the website contains information about all cultural and natural attractions in this area. In order to inform potential

tourists about a tourist destination, there should be data on the most important tourism events, as well as the most popular tourist offers.

Conclusion

Rural tourism is an important component of sustainable development and revitalization of rural areas in the vicinity of protected nature reserves and cultural heritage. Its development encourages the development of local markets for agricultural products and, thus, promotes employment. Rural areas are a fundamental prerequisite for the development of rural tourism. VIKOR method has revealed that in the area of the Danube region there are predominantly rural and intermediate rural municipalities. Analysis of cultural and natural resources indicates that tourist potentials of the Danube region in Serbia are reflected in immense cultural, historical, and natural resources and in environmental preservation of the area. However, analysis of the website containing information about the Danube region in Europe shows that there is not enough information on these cultural and natural resources. In addition, information on tourism events and accommodation facilities in this area is also lacking. The availability of all this information and online booking of accommodation facilities would contribute to the significant development of rural tourism in the Danube region in Serbia.

Literature

1. Beirne Elizabeth, Curry Philip (1999): *The impact of the internet on the information search process and tourism decision making*, In D. Buhalis & W. Schertler (Ed.), *Information and communication technologies in tourism 1999*, Springer-Verlag, Wien, 88-96.
2. Bratić Marija, Petrović Jelena, Živković Jelena (2011): *Stanje i perspective razvoja turizma na prostoru Stare planine*, *Ekonomске teme*, 2, 323-337.
3. Brunori Gianluca, Rossi Adanella, Cerruti Raffaella, Guidi Francesca (2009): *Nicchie produttive e innovazione di sistema: Un'analisi secondo l'approccio delle transizioni tecnologiche attraverso il caso dei farmers' markets in Toscana*, *Economia Agro-Alimentare*, 11: 143-170.

4. Čikić Jovana, Jovanović Tamara (2015): *Difuzija znanja i razvoj ruralnog turizma u Vojvodini*, Prirodno matematički fakultet, Novi Sad.
5. Danube Travel, <http://www.danube.travel/main-menu/danubetravel.1.html> (20.09.2016)
6. Dimitrios Buhalis, Rob Law (2008): *Progress in information technology and tourism management: 20 years on and 10 years after the Internet — The state of eTourism research*, Tourism Management 29, 609–623
7. Đorđević Dejan (1996): *Moguće promene u načinu korišćenja zemljišta na regionalnom nivou: tri različita scenarija za Podunavlje u Srbiji*, Udruženje urbanista Srbije, Beograd.
8. Epler-Wood Megan (2002): *Ecotourism: Principles, practices & policies for Sustainability*, UNEP; International Ecotourism Society, Paris.
9. European Commission, *Indicators in the rural development report 2013* http://ec.europa.eu/agriculture/statistics/ruraldevelopment/2013/indicators_en.pdf (15.09.2016)
10. Eurostat (2010): *A revised urban-rural typology*, Eurostat, Eurostat regional yearbook, Publications Office of the European Union, Luxembourg.
11. Gavrilă-Păven Ionela, Bârsan Mircea Constantin, Lia-Dorica Dogaru (2015): *Advantages and Limits for Tourism Development in Rural Area - Case Study Ampoi and Mures Valleys*, Procedia Economics and Finance 32, 1050 – 1059.
12. Internet live stats, <http://www.internetlivestats.com/internet-users/> (15.08.2016)

13. Internet Serbia Travel News, <http://www.istnews.com/sela75.htm> (01.09.2016)
14. Liu Peide, Wang Minghe (2011): *An extended VIKOR method for multiple attribute group decision making based on generalized interval-valued trapezoidal fuzzy numbers*, Scientific Research and Essays, 6, 766-776.
15. Milićević Snežana, Podovac Milena, Čavlin Miroslav (2015): *Resources for development of the Rača municipality as rural tourism destination*, Ekonomika poljoprivrede, 62(3), 751-765.
16. Milićević Snežana, Đorđević Nataša (2015): *Potencijali za razvoj planine Goč kao destinacije ruralnog turizma*, Ekonomija, teorija i praksa, 8(4), 86-97
17. Nikolić Milan, Radovanović Ljiljana, Desnica Eleonora, Pekez Jasmina (2010): *Primena metode VIKOR za izbor strategije održavanja*, Tehnička dijagnostika, 9(4), 25-32
18. OECD (1994): *Creating Rural Indicators for Shaping Territorial Policy*, OECD, Paris.
19. OECD (1996): *Territorial Indicators of Employment - Focusing on Rural Development*, OECD, Paris.
20. OECD (2006): *The New Rural Paradigm - Policies and Governance*, OECD, Paris.
21. Oliver David, Livermore Romm, Sudweeks Fay (2009): *Self-service in the internet age: Expectations and experiences*, Springer, London.
22. Opricović Serafim (2009): *Compromise in cooperative game and the VIKOR method*, Yugoslav Journal of Operations Research, 19(2), 225-238.

23. Opricović Serafim, Tzeng Gwo-Hshiung (2007): *Extended VIKOR method in comparison with outranking methods*, European Journal of Operational Research, 178(2), 514-529.
24. Petrović Jelena, Ivanović Marko (2011): Internet – sredstvo komunikacije i distribucije u hotelskoj industriji, CM – časopis za upravljanje komuniciranjem, 6(20), 117-129.
25. Registar zaštićenih prirodnih dobara, 2012, http://serbianoutdoor.com/wpcontent/uploads/2012/08/registar_zastice_nih_dobara_cirilica.pdf (20.08.2016)
26. Republički zavod za statistiku (2014): *Demografska statistika u Republici Srbiji*, Beograd.
27. Republički zavod za statistiku (2015) *Opštine i regioni u Republici Srbiji*, Beograd.
28. Roberts Lesley, Hall Derek (2001): *Rural tourism and recreation: Principles to practice*, CABI Pub, New York.
29. Sgroi Filippo, Di Trapani Anna Maria, Testa Riccardo, Tudisca Salvatore (2014): *The Rural Tourism as Development Opportunity of Farms. The Case of Direct Sales in Sicily*, American Journal of Agricultural and Biological Sciences 9 (3), 407-419.
30. Shannon Claude, Weaver Warren (1947): *The mathematical theory of communication*, The University of Illinois Press, Urbana.
31. Sharpley Richard, Sharpley Julia (1997): *Rural tourism: An introduction*, International Thomson Business Press, London.
32. UNWTO (2001): *eBusiness for tourism: Practical guidelines for destinations and businesses*, World Tourism Organisation, Madrid.

ENVIRONMENTAL SUSTAINABILITY IN RURAL TOURISM¹

Jovana Čikić, Marica Petrović²

Abstract

In the paper, we have analyzed basic ideas regarding the necessity of greening the rural tourism. We have started with the idea that sustainability is necessary in functioning of the contemporary rural tourism system in order to provide its long-term positive effects in rural communities` development. The significance of sustainability in rural tourism development is analyzed from the perspective of characteristics of tourism attractors. Greening the rural tourism is based on eco-management principles and use of clean technologies. Their direct and indirect use in rural tourism should contribute not only to the fulfilment of rural tourists` and rural hosts` needs, but benefit rural population in general.

Key words: *environmental sustainability, clean technologies, neo-endogenous rural development, rural tourism*

Introduction

There is no doubt that tourism is one of the prosperous global economies. According to the UNWTO (2013), tourism makes approximately 9% of global GDP and employs around 200 million workers globally. It is important sector for both developed and developing economies. In developing countries, tourism often represents crucial component of development and main force in reduction of poverty and social exclusion (UNWTO, 2013). Its promising prospects made tourism receptive for

¹ The paper is a part of the research on the project III46006 (Ministry of education, science and technological development of the Republic of Serbia, 2011-2016).

² Jovana Čikić, Ph. D., assistant professor, University of Novi Sad, Faculty of Philosophy, Department of Sociology, 21000 Novi Sad, Zorana Đinđića 2, phone: +381642850727, e-mail: jovana.cikic@ff.uns.ac.rs;

Marica Petrović, M.Sc. teaching assistant, University of Novi Sad, Faculty of Agriculture, Department for economics of agriculture and rural sociology, 21000 Novi Sad, Trg Dositeja Obradovića 8, phone: +381612699090, e-mail: maricam@polj.uns.ac.rs.

various environmental, economic, social and cultural contexts. Advance in tourism has also induced diversification of tourism offer, experiences, destinations, target groups, etc. so today we speak of dozens of selective forms of tourism. One of it is rural tourism. According to the available data³, European rural tourism in 2014 (along with the related services) has generated more than €100 billion in direct spending, mostly in the local economies. Rural tourism is based on maximal mobilization of rural capital in order to create new, both tangible and intangible values which should contribute to the improvement of rural population's quality of life.

The important impetus for the idea of rural tourism development came from the concept of the neo-endogenous rural development. Based on available rural capital, this concept greatly exploits the idea of sustainability. Consequently, rural tourism and sustainable rural development are connected. Thus, we argue the necessity to establish the idea and practice of rural tourism on long-term and stable foundations of sustainable (local) rural capital. At the same time, practice of rural tourism should benefit achieving goals of sustainable rural development.

Nevertheless, both conceptual and practical levels of the analysis of the relation between rural tourism and rural development show that neither rural tourism is a magic wand for fixing often multiple rural communities' problems nor sustainability is easy to achieve and maintain. Available data reveal growing interest in rural tourism, both in terms of supply and demand. This is certainly a positive trend contributing to the economic sustainability of rural households and communities in general. On the other side, making rural tourism more popular implies substantial adjustments of rural landscapes to the rural tourists' and rural hosts' needs. Intense modifications in rural landscapes question quality of rural environment and solid foundations of rural sustainability. Thus, we have analyzed the elements of the relation between rural tourism and sustainable rural development, especially those regarding demand for environmental sustainability of rural tourism system. We have started with three basic ideas:

- rural development is not long-term possible unless environmental sustainability is not accepted as one of the imperatives in development of specific dimensions of rurality, specific activities and rural communities in general,

³ Data from the: <http://agroxenia.net/en/5th-european-congress-rural-tourism-european-rural-tourism-2020>.

- system of rural tourism can be functional in long terms only if accepts sustainability principles,
- one of the mechanisms in achieving sustainability of rural tourism is its greening by use of clean technologies.

The aim of the paper is to indicate the requirements, possibilities and limitations in the greening the rural tourism. Presented ideas have been analyzed with regards to the relevant scientific literature on sustainable/neo-endogenous rural development and sustainable rural tourism, as well as examples of good practice.

The role of rural tourism in neo-endogenous rural development

Original and generally accepted broad definition of sustainable development (World Commission on Environment and Development, 1987) enables it to address different spheres of social life as well as to easily include various social goals. Thus, it is no surprise that elasticity in concept of sustainable development made it widely and rapidly acceptable. Even though the concept can be criticized in domain of sustainability of sustainable development as theoretical and practical issue (Pušić, 2012), we have chosen to speak of sustainable rural development for two reasons. First, this concept clearly emphasizes the necessity of environmental protection as a precondition of rural development. Second reason relates to the accentuation of unity and synergy in performance of different dimensions of sustainable development: from economic, social, political, cultural to the environmental dimension of rural community development⁴.

Advance in theoretical and practical perception of the rural development idea can be traced through three concepts: exogenous, endogenous and neo-endogenous rural development⁵. All of them actually indicate development of characteristics of rurality (Sotte, 2003) – from agrarian through industrial to post-industrial/post-modern rurality. Currently prevailing is the concept of neo-endogenous rural development. It emphasizes the significance of rural potentials and participation of

⁴ Besides, we can speak of moral, technical, legal dimension of sustainable development (Pawlowski, 2008).

⁵ Hubbard and Gorton (2009) wrote of fourth concept – agrarian development. [http://ageconsearch.umn.edu/bitstream/53334/7/5_final_Hubbard IAAE09.pdf](http://ageconsearch.umn.edu/bitstream/53334/7/5_final_Hubbard%20IAAE09.pdf)

relevant stakeholders in implementation of developmental measures and activities. Territorial approach is being advocated, instead of sectorial. Eradication of rural social exclusion is not possible without diversification of rural economy, progress of rural infrastructure and rural suprastructure, diffusion of knowledge and innovation and insisting on preservation of rurality as a way of life.

The essence of neo-endogenous rural development is in synergy of local and global processes and actions at the rural community level. According to Ward et al. (2005), neo-endogenous rural development entails capacity building for the mobilization of internal rural resources and active control of external influences. Solutions of local problems enable rural community to develop social vitality (Čikić, 2013), or to preserve its functionality „*without loss to ecological, social and economic capitals in the long run, whatever occurs as a result of exogenous changes beyond its control*“ (Dale, Ling, Newman, 2010). Thus, neo-endogenous rural development implicitly entails the idea of sustainability.

Neo-endogenous rural development is based on new perception of rural space. Its key characteristic is multifunctionality (Illbery & Bowler, 1998). New ways of the use of rural space open multiple possibilities of its transformation which is in accordance with the „*multiple and various social preconditions for the consumption of the rural public goods*“ (Čikić, 2015). Besides being multifunctional, contemporary rural space is also multifaceted (Halfacree, 2006). Presented qualifications of rural space crucially determine possibilities of reproduction of rurality and potentials of rural development.

Sustainability in neo-endogenous rural development often refers to the concept of sustainable livelihoods. „*A livelihood is sustainable which can cope with and recover from stress and shocks, maintain and enhance its capabilities and assets and provide sustainable livelihood opportunities for the next generation; and which contributes net benefits to other livelihoods at the local and global levels and in the short and long term*“ (Chambers, Conway, 1991). Common characteristic of both concepts is their orientation on: a) human needs and possibilities, b) support to the idea of active participation and partnership and c) finding the solutions for overcoming the social vulnerability and exclusion. Also, both concepts are dynamic and holistic. Achieving sustainable livelihoods also refers to strengthening the efficiency in the use of available resources as well as synergic development of small scale economies (Chambers, Conway,

1991). This is the point of building the idea of rural tourism as means in achieving sustainability in neo-endogenous rural development. Sharpley (2003) argues similar when wrote „*as tourism has become increasingly viewed as an effective means of addressing the socio-economic challenges facing peripheral rural regions, ... sustainability – both optimising the development benefits of tourism and satisfying the needs of tourists within strict environmental parameters – has become a dominant principle and objective*“.

Compatibility of rural tourism with the sustainability of neo-endogenous rural development can easily be traced in very definition of rural tourism. According to Lane (1994), rural tourism is a form of tourism which is rural by its functionality („*developed based on specific rural characteristics*“) and local by scope, goals and control of economic activities (small scale enterprises with the idea of „*long-term benefits for the rural community*“). Vital features of rural tourism listed above - locality and rurality - ideally fits to the general preconditions of sustainability in neo-endogenous rural development. Rural tourism requires maximal mobilization of available local rural/countryside capital which entails rural landscape, biodiversity, geological diversity, quantity and quality of land, air quality, quantity and quality of water resources, rural settlements, economic and residential facilities, infrastructure, cultural and historical sites, rural culture as a specific way of life (Garrod et al, 2004; according to: Garrod, Wornall, Youell, 2006). Without rural capital - both natural and anthropogenic - the creation of tourist offer of the experience in rurality is not achievable. In addition, development of rural tourism is based on advance in local initiatives which is in accordance with the basic principles of sustainability in neo-endogenous rural development. This is a path towards strengthening the social capital of rural population. It also enables rural population's networking with various stakeholders in rural development. Local initiatives also foster good practice of local governance (Shucksmith, 2010) under the terms of frequent and multilayered interactions of local/rural with global (business, political, institutional, etc.) environments.

In contemporary sociological (and similar) literature, concept of neo-endogenous rural development is often connected with the idea of knowledge economies/societies. Ward, Atterton, Kim, Lowe, Phillipson and Thompson (2005) saw the main reason for such practice in the necessity of restructuring current rural economies and developing new rural economies. Its goal is „*diversification of farm businesses into non-*

agricultural enterprises, the promotion and development of rural SMEs and micro-businesses, the encouragement of community enterprise, especially through the initiatives such as EU's LEADER programme, and efforts to rethink the economic roles and functions of small towns in rural areas“ (Ward et al., 2015). Initial premise of knowledge economy matches one of the goals, but also principles in neo-endogenous rural development - strengthening human, social and cultural rural capital.

Besides productions of good (food and raw materials), new rural economies are based on commodification of rural space and rurality which enables development of rural service sector and intensive application of new technologies (Copus, 2014). The imperative of new rural economies is resilience. It refers to the *„ability of a local rural economic system to absorb shocks, such that it returns or adjusts to a new stable growth path following a 'big' event (shock) or regime shift“* (Tonts, Plummer, Argent, 2014). Resilience is based on rural social vitality and rural capital.

One of the key questions in researching rural tourism is nature of its role in development of contemporary local rural communities. The answer is in the relations between rural tourism and abovementioned concepts in understanding the rural development in contemporary societies. Rural tourism rests on creation of tourist experience based on commodified rurality. By focusing on experience as primary (economic) value and tourist product as well, rural tourism infiltrate not only in the area of experience economy, but also knowledge economy which should enables specific, individualized and authentic consumption linked to the emotional satisfaction (Novelli, 2005). In order to facilitate the adequate design of rural tourism experience (compatible to the needs and desires of consumers/rural tourists), rural hosts reach for the twofold resources: first ones are local and specifically rural (rural capital) and second ones are universal (contemporary business` knowledge and technologies). Thus, in rural tourism elements of neo-endogenous rural development are combined with the principles of knowledge economies. Also, whether it is understood as a: a) way of thinking, b) development of specific characteristics of existing services/products or c) creation of completely new services/products (Tussyadiah, 2014), the design of the rural tourism experience comprises of substantial use of new technologies (especially in communication) which corresponds to the principles of the new rural economies. Obviously, development of rural tourism directly contributes to the sustainability of livelihoods by creation of opportunities for (self)employment of rural population (especially rural women and rural

youth as frequently economically excluded). At the same time, engagement in rural tourism contributes to the development of various knowledge and skills that boost up the rural human capital, thus improving their position on rural labour market. Rural tourism requires rural infrastructure and sufficient suprastructure which improve quality of life of both recipient and non-recipient rural population. By horizontal and vertical networking throughout market, professional organizations and associations, rural tourism strengthens social capital of rural population which facilitates their participation in decision making and governing the local rural communities. All listed above indicate that entrepreneurship in rural tourism has broader social implications. Potentially, advance in rural tourism can soften up negative demographic trends - rural depopulation. By using rurality as a foundation for rural experience design, rural tourism can contribute to the cultural sustainability throughout maintenance of the rural cultural heritage. According to Čikić and Jovanović (2015) *„effects of rural tourism are not limited by local community's physical and social space. They spread over the local boundaries, thus rural tourism development can boost up and contribute to the more balanced regional development“*.

Why „greening up“ the rural tourism?

Besides mentioned positive effects, rural tourism can also produce negative impact on rural communities/areas. Thus, in rural economy, rural tourism can additionally aggravate rural population's market position due to the seasonality of demand for labour force in rural tourism. Besides, working terms in rural tourism are often unfavourable (long working hours, seven days working week, physically and psychologically strenuous work). Development of rural tourism, especially in rural communities/areas with modest rural capital, could caused condition of economic and technological dependency of other communities/areas which raises an issue of possibilities for the local control and retain of benefits from rural tourism. Commodification of rurality for tourism purposes could potentially cause loss of rural cultural specifics and tradition. Also, intensive growth of rural tourism offer could potentially result in depersonalization of human relations and social conflicts. At last, third group of potential negative effects of rural tourism development refers to the changes in environmental quality. Even though preserved/intact nature is one of the main features in the design of rural tourism experience, intensification of contacts between rural tourists - rural hosts could cause increase in environmental problems. Development

of general and tourism infrastructure could result in vast modification of rural space with the tendency of overcrowding. Transport in rural tourism also produces air pollution. Increase in accommodation and catering facilities could generate intensification of consumption, but also pollution of rural water resources. Also, they could create increase in use of non-renewable energy resources. As rural tourism offer significantly relies on natural resources, activities in tourism could endangered rural biodiversity. Rural tourism also could have indirect impact on increase of environmental problems. Advance in additional services, functionally linked to the rural tourism, also makes pressure on delicate balance between natural and anthropogenic elements of rural environment (e.g. intensification of agriculture within small-scale food chains, development of rural service sector in general).

All the mentioned reasons caused the necessity to put rural tourism (tourism in general) on sustainable foundation. Even though there is no generally accepted definition of sustainable tourism, we argue that sustainable tourism is such form of tourism that *„tourism which is developed and maintained in an area (community, environment) in such a manner and at such a scale that it remains viable over an infinite period and does not degrade or alter the environment (human and physical) in which it exists to such a degree that it prohibits the successful development and well being of other activities and processes“* (Butler, 1993; navedeno prema: Butler, 1999). Accordingly, sustainable rural tourism can be defined as tourism that manipulate with the existing and projected economic, social, cultural and environmental influences in order to enable current and future needs of tourist, tourism industry and local rural communities. According to our subject of the research, we are concentrating only on environmental sustainability in rural tourism.

Achieving environmental sustainability in tourism and rural tourism as well implies creation of *environmentally friendly* tourism offer and practice. „Greening“ the rural tourism has twofold goal. First one is creation of specific rural tourism offer. Maintained natural environment as an integral element of the rural way of life is emphasized as a value per se and as a competitive advantage in creation of rural tourism experience. For example, in *Master Plan of Sustainable Development of Rural Tourism in Serbia* (Vlada Republike Srbije, 2011) it is stated that natural attractors in rural areas in Serbia are *„very well preserved and have great potential“*. In the Plan, there are ten identified natural attractors that could be (and that are) integral elements of specific national, regional and local rural tourism offers. Second

aim in „greening“ the rural tourism implies focusing on specific tourism practice in accordance with the environmental standards. Such goal corresponds with the requests of the specific target group of rural tourists (but rural hosts as well) who perceive interweaving of natural and anthropogenic within rural context as extremely significant and thus worth maintaining and improving⁶. The significance of environmental sustainability for rural tourism development is reflected in the very character of tourism attractors. Besides anthropogenic elements, rural tourism relies on natural environment to create specific tourism offer. In rural culture, there is clear and undoubted unity of „natural“ and „social“ culture. According to Koković (2005) „ *man and his culture cannot be isolated from the environment (natural surrounding - N.A.) they grew up from and stay inseparable... the culture is humanized nature*“. Therefore, dichotomy nature – culture are perceived as a false dilemma, within the rural context. Body (as a manifestation of the nature) and spirit (as a manifestation of the culture) are hereby joint as one. Such unity reflects also in the fact that „*culture is everything countryside made in the practice of its reproduction*“ (Stojanov, 2004). Under such understanding of rural culture, agriculture and rurality make the backbone of creative relation of man towards his (natural) surroundings.

Scheme 1. Components of „greening“ rural tourism

Environmental responsibility	Local economic vitality
1. protecting, conserving, and/or enhancing nature and the physical environment to ensure the long-term health of the life-sustaining ecosystem 2. recovery from the current and prevention of potential environmental problems caused by tourism and accompanied activities (e.g. in agricultural and non-agricultural activities)	1. supporting local economies, businesses and communities to ensure economic vitality and sustainability. 2. development of rural entrepreneurship and self-employment in order to minimize rural unemployment and poverty 3. diversification of rural economy in achieving sustainable livelihoods 4. horizontal and vertical linking additional economic activities with the rural tourism businesses
Cultural diversity	Richness of experience
1. respecting and appreciating cultures and cultural diversity so as to ensure the continued well-being of local or host cultures 2. support for the transformation of traditional peasant culture into the contemporary rural culture 3. preventing rural culture to become pulp	1. providing enriching and satisfying experiences through active, personal and meaningful participation in, and involvement with, nature, people, places and/or cultures

Source: *Dodds, Joppe, 2001; author*

⁶ Thus, it is no surprise that environmentally sustainable rural tourism is also known as responsible tourism.

Achieving and preserving environmental sustainability in rural tourism is based on complementary development of rural and ecological („green“) tourism within rural milieu⁷. Such development puts ecological tourism outside the protected natural areas. Thus, Romelić, Košić i Pivac (2005) stated that positioning rural tourism on environmentally sustainable foundations leads towards creation of eco-rural destination with the identity based on the „*concept of cumulative attractions*“. Such destinations enable tourists to enjoy nature and to reconnect their lost/reduced relation with natural environment. In addition, rural tourism enables identification of quality of rurality in characteristics of „*traditional social structure as well as general social values*“ (Romelić, Košić, Pivac, 2005).

How to „green up“ the rural tourism?

Recent, mainly practical efforts show numerous requests and attempts to „green up“ the tourism in general and rural tourism as well. The idea of linking tourism with environmental protection has its long-term international history of practice (Hashimoto, 1997). The significant influence on advance in environmental sustainability of rural tourism gave also the changes within rural development policies. Thus, the LEADER initiative (1991) obviously depicts the importance of strengthening non-governmental sector as well as public-private partnerships in rural environmental protection. *Cork declaration* in the 1996. and especially its innovated version in the 2016., *Cork declaration 2.0*, insist on rational use of natural resources in rural economy, control of climate changes and protection of rural environment because its inner value „*provides benefits to local economic development, eco-tourism, healthy living, food identity and branding as well as the promotion of the countryside for recreation*“ (Cork Declaration 2.0, 2016). Reforms of the CAP (especially reforms in the 2003. and in the 2013.) introduce new standards as criteria for granting support to farm development (e.g. protection of land quality, obligatory in biodiversity protection and plants` and animals` welfare). Current CAP insists on strengthening environmental sustainability not only of agriculture, but rural economy in general in order to maintain rural natural heritage. Thus, within the first pillar of CAP a new instrument has been introduced – *greening* – aiming

⁷ Thereby, it seems that in literature there is more references on *greening* of urban tourism, because of the characteristics of urban environment and more intensive and extensive environmental problems (Dodds, Joppe, 2001)

to support those in rural areas who provide public service for the general good (e.g. protection of biodiversity, fostering specific rural landscapes etc.) (European Commission, 2013).

Besides practical efforts, encounter of rural tourism and environment occurs at the theoretical level as well. According to Hashimoto (1997), the focus of the research of the relation between rural tourism and environment has been moved from more „*orthodox concerns about natural resource management and planning, environmental features and recreational opportunities, to newer areas of ecotourism, in which tourism is regarded as a part of sustainable development*“.

Practice of greening the rural tourism entails implementation of the new, green or clean technologies in the processes of creation and provision rural tourism offers. The aim of use of clean technologies is to minimize energy consumption, maximize the use of renewable energy resources and achieve adequate quality of provided service. Large hotel complexes were the first to adopt the idea of greening the tourism offers. Today, it is often spoken of green projects which represent integrative projects of environmentally sustainable development of tourism destinations.

The first step in application of eco-management principles in rural tourism is situation analysis based on management quality control. The main indicator for situation analysis is environmental capacity or capacity of rural tourism destination to fulfil the needs of current, but also future estimated number of tourists. Further activities on greening the rural tourism entails regular environmental balance sheets of rural tourist facilities, destinations and products (Đorđević, Kokić Arsić, 2010).

We could speak of direct and indirect use of clean technologies in rural tourism. In the first case, we think of direct application of technologies with reduced or no negative impact on environment in the process of creation and providing services in rural tourism. Clean technologies are more likely to be use in waste management. Their use implies adequate infrastructure for waste separation. It also requires sufficient information for tourists on possibilities and necessities of such waste management practice. Waste separation enables recycling. By waste in rural tourism, we understand waste in narrow and broad sense. Waste in narrow sense refers to the one generated at the daily basis (e.g. paper waste, food/organic waste, plastics). Nevertheless, rural tourism provides opportunities for recycling waste in broader sense, such as old

construction materials (e.g. brick, wood), used furniture and other household items, fabrics etc. which could be used in creation of rural tourism offer. More sophisticated practice in sustainable waste management requires development of infrastructure for waste water treatment, at the micro level (rural tourism facility) or at the level of rural destination. Besides new waste management, the use of clean technologies in rural tourism includes the intensive use of renewable energy resources. Depending on climate characteristics of rural tourism destination, it is possible to build individual solar collectors on facilities or to integrate accommodation facilities in rural tourism into the system of wind turbines (which implies mutual and coordination activities at the local rural community level). The advance in public transportation, as well as alternative form of transportation (e.g. cycling) reduce air pollution and help creation of new rural tourism offers. The new use of clean technologies also entails noise reduction, maintenance of land quality and general protection of water resources.

On the other side, indirect use of clean technologies in rural tourism involves their integration in the processes of production of goods and provision of services which contributes to the tourism offer. One of the indirect ways of greening the rural tourism is introduction of organic agriculture principles in the production of food to be used in creation of gastronomic offer⁸. Next to the environmental incentives (Čikić, Petrović, 2010), organic farming and green rural tourism as well directly rely on the concept of multifunctional agriculture. Such concept promotes the demand for re-grounding the family farms (and other stakeholders in organic farming and rural tourism as well) as „*multifunctional enterprises that should provide greater choice of goods and services*“ (Čikić, Petrović, 2010) and to contribute to general welfare in rural community. Privitera (2010), Pelikan-Matetić and Pelikan (2008) and Wachter (2006) wrote of practice, possibilities and difficulties in implementing organic farming into the rural tourism. There are several examples of such routine in rural tourism in Serbia, especially in tourism on *salaši*. Kuo, Chen and Huang (2006) have concluded that integration of organic farming with rural tourism contributes not only to the green production of health safe food but to creation of specific tourist experience. Rural eco-lodges can also be an example of systematic greening the rural tourism. Eco-lodge is often an element of previously mentioned integrated projects of environmentally sustainable development of rural tourism destinations. It

⁸ It is also called bio-agritourism.

is a specific type of facilities in rural tourism that refers to the smaller accommodation facilities located near or in the natural landscapes. Rural eco-lodges implies active application of eco-management standards (waste separation and recycling, water consumption control, use of renewable energy resources, use of environmentally friendly construction materials, etc). They differ from the conventional accommodation facilities in rural tourism by three criteria: food, activities and design (Russell et al., 1995; according to: Osland, Mackoy, 2004). In order to be classified as a eco-lodge, rural accommodation facility has to fulfil certain criteria. Csapó, Szabó, Szabó (2015) stated defined criteria⁹ for eco-lodges in rural tourism in Hungary: energy consumption saving, water consumption saving, waste reduction, reflexive functioning, provision of information for the tourists. According to the authors (Csapó, Szabó, Szabó, 2015), three factors are crucial for the maintenance of the rural eco-lodge: a) environmental factors (especially those related to use of clean technology for savings in energy consumption), b) factors regarding to the accommodation (which include utilization of environment friendly/local construction materials and public display of elements of rural cultural heritage) and c) factors relating local products (their production, advertising, distribution and sale). As previously mentioned, activities in rural eco-lodges also include providing information to tourist on environmental protection, but cultural heritage of the rural tourism destination. Thus, rural eco-lodges are not only a specific type of accommodation facilities, but special type of rural tourism offer that emphasises participation of tourists in local activities. In that way, rural eco-lodges are an opportunity for tourists for encounter with local rural population and rural landscapes and to experience authentic rural hospitality experience (Cerović, Drpić, Miložica, 2012).

Conclusion

There are two paths in analyzing consequences of greening the rural tourism. Both starts with the premise that process of greening goes beyond the limits of rural tourism system. In the first case, focus is on stakeholders within the greening process. The outcome of the greening the rural tourism is only the creation of new tourism offers. Thus, greening is only a mechanism for fulfilling the rural tourists' and rural hosts' requirements. In fact, the effects of greening the rural tourism are

⁹ The criteria are defined within the project of development of the rural eco-lodges network.

reflected on rural non-recipient population as well. This especially refers to the positive effects such as revival of rural communities and improvement of rural quality of life. Nevertheless, rural recipient and non-recipient population could differently perceive benefits from rural tourism. Such different perceptions might be a cause of potential conflicts. Participative planning at the local rural community level could be applied as a mechanism for overcoming the potential conflicts. It enables various stakeholders in greening the rural tourism to be include in processes of its development. Such practice also contributes achieving basic principle of environmental sustainability in rural tourism which „actively fosters environmental and cultural understanding, appreciation and awareness, both among its visitors as well as among the staff and local inhabitants“ (Hagberg, 2011).

On the other hand, the effects of greening the rural tourism goes beyond environmental protection and affect other dimensions of sustainability. Even though positive effects on economic sustainability¹⁰ are most likely to be emphasized, greening the rural tourism has a positive impact on cultural, political and social dimension of sustainability. Process of greening has a major contribution to the development of responsible rural tourism as a practical outcome of sustainability principles' application.

Nevertheless, the process of greening the rural tourism has certain limitations. First, the use of clean technologies in rural tourism requires (often substantial) starting investments. Even though project funding could be useful, there is a justified concern that end of the project funding would result in disappearance of general financial funds for further activities in greening the rural tourism. Second, there is an issue of rural hosts' motivation for introducing clean technologies in their everyday practice due to the often postponed and not easily detectable effects of their use. Third limitation refers to the demand pressure. The application of eco-management principles in rural tourism could increase prices of tourist offers which potentially could decrease interest in visiting rural tourism destinations. Forth limitation in the greening process is the common for all previously mentioned. It refers to the lack of knowledge of characteristics of the greening process, its premises and limitations, its costs but also benefits. Moreover, it refers to the underdevelopment general environmental awareness of rural population which makes difficult for

¹⁰ Encouraging employment, entrepreneurship, development of other production and service in rural economy, rural poverty reduction, etc.

them to understand to necessity of environmental sustainability of rural development and environmental sustainability of activities held in rural space. Thus, diffusion of knowledge and innovation is pointed out as means in facilitating the maturation of environmental responsibility in form of beliefs and skills that are applicable in the process of greening the rural tourism (Smolčić Jurdana, 2009).

Literature

1. Butler Richard (1999): *Sustainable tourism: A state-of-the-art review*, Tourism Geographies, Routledge, UK, Vol. 1, Iss. 1, pp. 7-25.
2. Cerović Ljerka, Drpić Danijel, Milojica Vedran (2012): *Green Technologies And Sustainable Development: Factors Of Competitiveness In Tourism And Hospitality Industry*, Yumusak Ibrahim Guran (ed.) 10th International Conference on Knowledge, Economy and Management, Istanbul Medeniyet University, Turkey, pp. 1852-1865.
3. Chambers Richard, Conway Gordon (1991): *Sustainable rural livelihoods practical concepts for the 21st century*, IDS, UK.
4. Copus, Andrew (2014): *New rural economy and macro scale patterns*, in: Copus Andrew, de Lima Philomena (eds.): *Territorial Cohesion in Rural Europe: The Relational Turn in Rural Development*, Routledge, UK-USA.
5. Csapó János, Szabó Géza, Szabó Katinka (2015): *From Eco Lodges To Baranya Greenway: Innovative Rural Tourism Product Brands In South Transdanubia*, Acta Geographica Universitatis Comenianae, Geographical Section of the Faculty of Natural Sciences of the Comenius University, Bratislava, Vol. 59, No. 2, pp. 203-217.
6. Čikić Jovana, Petrović Živojin (2010): *Organska proizvodnja i poljoprivredna gazdinstva u Srbiji*. Poljoprivredni fakultet, Novi Sad.
7. Čikić Jovana (2013): *Socijalna vitalnost u istraživanju ruralnog razvoja*, Zbornik Matice srpske za društvene nauke, Matica srpska, Novi Sad, Vol. 143, pp. 293-306.

8. Čikić Jovana (2015): *Transformacija ruralnog prostora u savremenim društvima*, u: Milenković Pavle, Stojšin Snežana, Pajvančić-Cizelj Ana (ur.) Društvo i prostor - urbani i ruralni proctor, Srpsko sociološko društvo - Filozofski fakultet u Novom Sadu - Institut za uporedno pravo, Novi Sad – Beograd, str. 151-172.
9. Čikić Jovana, Jovanović Tamara (2015): *Difuzija znanja i ruralni turizam u Vojvodini*, Prirodno-matematički fakultet, Novi Sad.
10. Dale Ann, Ling Chris, Newman Lenore (2010): *Community Vitality: the Role of Community-Level Resilience, Adaptation and Innovation in Sustainable Development*, Sustainability, MDPI AG, Switzerland, Vol. 2, Iss. 2, pp. 215-231.
11. Dodds Rachel, Joppe Marion (2001): *Promoting urban green tourism: The development of the other map of Toronto*, Journal of Vacation Marketing, SAGE Journals, UK-USA, Vol. 7, Iss. 3, pp. 261-267.
12. Đorđević Milosav, Kokić Arsić Aleksandra (2010): *Ekološki menadžment - uslov održivog razvoja turizma*. (www.cqm.rs/2010/pdf/5/37.pdf, dana: 24.09.2016.)
13. European Commision (2013): *Overview of CAP reform 2014-2020*. (http://ec.europa.eu/agriculture/policy-perspectives/policy-briefs/05_en.pdf, dana 24.09.2016.)
14. Garrod Brian, Wornell Roz, Youell Ray (2006): *Re-conceptualising rural resources as countryside capital: The case of rural tourism*. Journal of Rural Studies, Science direct, UK – USA, Vol. 22, Iss. 1, pp. 117–128.
15. Hagberg Annika (2011): *What's an ecolodge? - a case study of ecotourism operations in Ecuador*, Center for Environmental and Climate Research, Lund University, Sweden.
16. Halfacree Keith (2006): *Rural space: constructing a three-fold architecture*, In: Cloke Paul, Marsden Terry, Mooney Patrick (eds) Handbook of rural studies, SAGE Publications, UK-USA-India, pp. 44-62.

17. Hashimoto Atsuko (1997): *Comparative Evolutionary Trends in Environmental Policy: Reflections on Tourism Development*, International Journal of Tourism Research, Wiley, USA, Vol. 1, Iss. 3, pp. 195-216.
18. Hubbard Carmen, Gorton Matthew (2009): *Agriculture and rural structural change: An analysis of the experience of past accessions in selected EU15 regions*, in: Buchenrieder, G., Möllers J. (eds.). (2009): *Structural Change in Europe's Rural Regions – Farm Livelihoods between Subsistence Orientation, Modernization and Non-farm Diversification*. IAMO Studies Series, Leibniz Institute of Agricultural Development in Transition Economies, Germany, Vol. 49, pp. 91-112.
19. Illbery Brian, Bowler Ian (1998): *From Agricultural Productivism To Post-Productivism*, In: Illbery Brian (ed.) *The Geography Of Rural Space*, Routledge, UK. pp. 57-85.
20. Koković, Dragan (2005): *Pukotine kulture*, Prometej, Novi Sad.
21. Kuo Nae-Wen, Chen Yin-Jen, Huang Chiou-Lien (2006): *Linkages Between Organic Agriculture And Agro-Ecotourism*, Renewable Agriculture and Food Systems, Cambridge University Press, UK, Vol. 21, Iss. 4, pp. 238-244.
22. Lane Bernard (1994): *What Is Rural Tourism?* Journal of Sustainable Tourism, Taylor and Francics, UK – USA, Vol. 2, Iss. 1-2, pp.
23. Novelli Marina (ed) (2005): *Niche Tourism: Contemporary Issues, Trends And Cases*, Elsevier, UK.
24. Osland Gregory, Mackoy Robert (2004): *Ecolodge Performance Goals And Evaluation*, Journal of Ecotourism, Taylor and Francis, UK – USA, Vol. 3, Iss. 2, pp. 109-128.
25. Pawlowski, Artur (2008): *How Many Dimensions Does Sustainable Development Have?* Sustainable Development, Vol. 16, Iss. 2, pp. 81-90.
26. Pelikan-Matetić Nikolina, Pelikan Z (2008): *Ekološka poljoprivreda i ekoturizam - koliko su ozbiljne namjere Hrvatske?* Agronomski glasnik: Glasilo Hrvatskog agronomskog društva, Hrvatsko agronomsko društvo, Hrvatska, Vol. 70, Iss. 2, pp. 159-169.

27. Privitera Donatela (2010): *The importance of organic agriculture in tourism rural*, Applied Studies in Agribusiness and Commerce, University of Debrecen - Faculty of Economics and Business, Hungary, Vol. 4, Iss. 1-2, pp. 59-64.
28. Pušić, Ljubinko (2012): *Da li je ideja o održivom razvoju održiva?* Teme, Univerzitet u Nišu, Niš, Vol. 36, Iss. 2, pp.425-442.
29. Romelić Jovan, Košić Kristina, Pivac Tatjana (2005): *The Condition and Possibilities of Development Rural Tourism in Mountain Part of Vojvodina Province*, Zbornik radova Geografskog institute Jovan Cvijić, Geografski institut Jovan Cvijić, Beograd, vol. 54, pp. 99-114.
30. Sharpley Richard (2003): *Rural Tourism And Sustainability - A Critique*, in: Hall Derek, Roberts Lesley, Mitchell Morag (eds) *New Directions In Rural Tourism*, Ahgate, UK – USA, pp. 38-53.
31. Shucksmith Mark (2010): *Disintegrated Rural Development? Neo-endogenous Rural Development, Planning and Place-Shaping in Diffused Power Contexts*, Sociologia Ruralis, Wiley, UK – USA, Vol. 50, Iss. 1, pp. 1-14.
32. Smolčić Jurdana Dora (2009): *Specific Knowledge For Managing Ecotourism Destinations, Tourism and Hospitality Management*, Fakultet za menadžment u turizmu i ugostiteljstvu, Hrvatska, Vol. 15, No. 2, pp. 267-278.
33. Sotte Frank (2003): *An Evolutionary Approach to Rural Development: Some Lessons for the Policymaker*. In: Slovensko kmetijstvo in Evropska unija. Društvo agrarnih ekonomistov Slovenije, Ljubljana. (http://stari.bf.uni-lj.si/daes/index_files/sotte_p1.pdf, dana 24.09.2016.).
34. Stojanov Mladen (2004): *Sociologija seoskih kolektiva*, Matica srpska - Zavod za proučavanje sela, Novi Sad - Beograd.
35. *The Cork Declaration* (1996) (http://ec.europa.eu/agriculture/rur/leader2/dossier_p/en/dossier/cork.pdf, dana 24.09.2016.)

36. *The Cork Declaration 2.0* (2016)
(http://ec.europa.eu/agriculture/events/2016/rural-development/cork-declaration-2-0_en.pdf, dana 24.09.2016.)
37. Tonts Matthew, Plummer Paul, Argent Neil (2014): *Path dependence, resilience and the evolution of new rural economies: Perspectives from rural Western Australia*, *Journal of Rural Studies*, Science Direct, UK – USA, *Vol. 36*, pp. 362–375.
38. Tussyadiah Iis (2014): *Toward A Theoretical Foundation For Experience Design In Tourism*, *Journal of Travel Research*, SAGE Journals, UK – USA, *Vol. 53*, *Iss, 5*, pp. 543-564.
39. UNWTO (2013): *Sustainable Tourism for Development Guidebook - Enhancing capacities for Sustainable Tourism for development in developing countries* (<http://cf.cdn.unwto.org/sites/all/files/docpdf/devcoengfinal.pdf>, dana 24.09.2016.)
40. Vlada Republike Srbije (2011): *Master plan održivog razvoja ruralnog turizma u Srbiji*, Beograd.
41. Wachter Carolyn (2006) *The Development of Agri-tourism on Organic Farms in new EU countries – Poland, Estonia and Slovenia*, Winston Churchill Memorial Trust (<http://orgprints.org/10860/1/winstonchurchill.pdf>, dana 24.09.2016.)
42. Ward Neil, Atterton Jane, Tae-Yeon Kim, Lowe Phillipe, Phillipson, Jeremy, Thompson Nicola (2005): *Universities, the knowledge economy and the 'neo-endogenous rural development'*, Discussion Paper, No. 1, Centre for Rural Economy, Newcastle University.
43. World Commission on Environment and Development (1987): *Our Common Future*. Oxford University Press, Oxford. (<https://sustainabledevelopment.un.org/content/documents/5987our-common-future.pdf>, dana 24.09.2016.)
44. <http://agro Xenia.net/en/5th-european-congress-rural-tourism-european-rural-tourism-2020>.

THE DEVELOPMENT OF SUSTAINABLE TOURISM AS A COMPONENT OF ECONOMIC DEVELOPMENT OF THE REPUBLIC OF SERBIA

Marijana Joksimović¹, Stevica Deđanski²

Abstract

The authors assume that the development of sustainable tourism is a key a component of economic development of the Republic of Serbia. Based on the available data relevant for studying the matter, the authors of the work contribute to a better understanding of sustainable tourism and its impact on the economic development of the Republic of Serbia. Time series used in this work include data relating to the period from 2005 to 2015, excluding macroeconomic indicator in an environment where data from the period from 2012 to 2015 were used. All the data used in the work are the annual data. Selected time series covering the period before and after the global economic crisis.

Key words: *development, sustainability, tourism, economics and the Republic of Serbia.*

Introduction

Sustainable development is a concept of development in compliance with the capacity of the environment and does not endanger the resources on which is based, and as such will enable future generations to develop (United Nations efforts for a better environment of the 21st century, 1992). It can be said that it is in fact a strategy that combines development and environmental problems. It includes a balanced economic, social and cultural development without compromising the environment, which will enable future generations to develop the use of resources in the same or even higher level. Sustainable tourism can be defined as "tourism that fully takes into account the present and future, social and economic

¹ Marijana Joksimović, PhD, Associate Professor, Faculty of Business Studies, University John Naisbitt, Belgrade; E-mail: joksimovicm@naisbitt.edu.rs

² Stevica Deđanski, PhD, Associate Professor, Faculty of Business Studies, Vršac, University John Naisbitt, Belgrade, E-mail: sdedjanski@naisbitt.edu.rs

conditions and takes care of the needs of individuals, sectors, local cultures and destinations, while contributing to a reduction in unemployment as well as the protection of local ecosystems."³

The main aim of sustainable tourism is to enable tourists satisfaction of own needs and learning about the natural, historical and cultural characteristics of unique environments, while preserving the integrity of the city and promote economic development and welfare of the local community.⁴

Sustainable tourism development requires the participation of all relevant interest groups on the basis of prior information, as well as strong political leadership to ensure wide participation and consensus building. Achieving sustainable tourism is a continual process that requires constant monitoring of the impact and use of the necessary preventive and or corrective measures whenever necessary.

The theoretical aspect of Sustainable Development and Tourism

Besides all the innovation that has brought sustainable development, we can conclude that its essence comes from the second half of the 19th century, when the first significant ideas on environmental protection appeared ,because the expansion of the industrial revolution was threatened the enviromental like never before in the history of civilization. The concept of sustainable development was presented by the World Commission on Environment and Development, Brundtland report in 1987, defining sustainable development as "development which meets present needs without diminishing the ability of future generations to meet their own needs".

It can be said that there is no common definition of the concept of sustainable development, although in the literature most often cited definition is of the World Commission on Environment and Development (UN World Commission on Environment and Development), the so-called. Bruntland Commission, which says: "Sustainable development is

³ Source: UNWTO

⁴ Dragan Nikolić, The project Sustainable Development of the Municipality Pirot and sustainable tourism in Stara Planina (<http://www.logos.org.rs/htm%20strane/odrzivi%20turizam%20na%20Star%20pl%20-%201.htm>)

development that meets the needs of the present without compromising the ability of future generations to meet their own needs" (WCED, 1987).⁵

The concept of sustainable development is based on three key principles:⁶

1. *The principle of environmental sustainability*, which ensures that development is compatible with the essential ecological processes, biological diversity and biological resources;
2. *The principle of social and cultural diversity*, which ensures that development is compatible with the cultural and traditional values of human communities, contributing to their integrity, and
3. *The principle of economic sustainability*, which ensures that development is economically efficient to open the possibility of the use of resources by future generations.

The last years of the 20th century and beginning of the 21st century have shown that tourism, as the world economy branch, in all relevant indicators achieved primacy over other branches of the economy. Data of the World Tourism Organization (WTO) for 2002 show that international tourist traffic increased by 714.6 million tourist arrivals, which is 3.1% more than in 2001. In 2001 the revenue of international tourism in the amount of 463.6 billion USD was achieved. According to the prediction of WTO, foreign tourist arrivals will reach one billion in 2010 and 1.56 billion by 2020.

Taking a leadership role and achieving a significant share of the global gross national product and total employment, tourism has taken also a significant responsibility in relation to the economic, social, cultural and natural environment.

The scope and significance of tourism clearly shows that it is not enough to develop new forms of "alternative" tourism in the sense that minimize negative effects and maximize the positive impacts of tourism development. The entire tourism sector must be developed and must be managed in

⁵ WCED (1987). Our Common Future - Report. UN World Commission on Environment and Development. Retrieved December 2nd, 2013, from <http://www.un-documents.net/our-common-future.pdf>

⁶ Jovičić D. (2000): Tourism and Environment - the concept of sustainable development, Foundation Andrejevic, Belgrade.

manner that it does not destroy the natural and socio-cultural environment; it is an obligation and responsibility of the tourism industry worldwide.

Sustainable tourism has several definitions. According to the definition of the Federation of Nature and National Parks, sustainable tourism is "all forms of tourism development, management and activities that lead to the preservation of the environment, social and economic integrity and well-being of natural, built and cultural resources for a continuous period" (FNNP, 1993). The publication issued by the Tourism Group and the World Wide Fund for Nature, defines sustainable tourism as tourism that "acts within the limits of natural ability to rejuvenate and future productivity of natural resources, which recognizes the contribution of people and communities, customs and habits have on the tourist experience; acceptance that these people must have a fair share of the economic benefits of tourism; and guided by the wishes of the local community in the areas of receptive "(Tourism Concern & WWF, 1992).⁷

"Under the responsible and sustainable development of tourism, we mean tourism development that meets the needs of present tourists, tourist destinations and all participators in tourism, while preserving and increasing the potential for the use of tourism resources in the future, without compromising the ability of future generations to meet their own needs. That means the improvement of the quality of life within the possibilities of the ecosystem that surrounds us. "⁸ Responsible and sustainable tourism development implies the right to tourism and the freedom of tourist movements, meeting of economic, social and aesthetic needs, while maintaining the characteristics of the natural and social environment, cultural and historical heritage.

Although the existing definitions vary according to what each of them highlights the most important, the main message of the Brundtland Report seems to be more and more accepted in the tourism industry worldwide. Either way, the notion of sustainability is a very complex and has many subterms.⁹

⁷ Ratz, T., Puczko, L. (1998): Rural tourism and sustainable development, Paper presented in the "Rural Tourism Management: Sustainable Options", Auchincruive, Scotland.

⁸ www.cenort.rs

⁹ Mowforth, M. and Munt, I. (1998): Tourism and Sustainability. New Tourism in the Third World, Routledge, London.

Environmental sustainability, which means that tourism development does not cause irreversible changes in a given ecosystem of destinations, is the most generally accepted dimensions, since it is a clear need around the world to protect the natural resources from the negative impacts of tourism activities.

Social sustainability refers to the ability of local communities to embrace tourism (tourism industry and the tourists themselves) without the creation of social disharmony.

Cultural sustainability means that a particular local community is able to keep (preserve) or adapt their own distinctive cultural mark despite pressure from the so-called "tourist culture" of visitors.¹⁰

Economic sustainability refers to a level of economic gain from tourism that is sufficient to provide some income to the local community and to cover all the costs of the specific measures to be taken in satisfaction of tourists (although the attractiveness of certain areas and the realization of need of high quality services are prerequisite for the economic viability, without the existence of competitive position on the world market, no destination can be economically sustainable).¹¹

Various aspects of sustainability should be seen as equally important. The high level of economic benefits should not be viewed as a means of covering the damage to the social and natural resources, but also relatively sensitive nature of these resources should not involve environmental planning without considering the economic aspects. Sustainable tourism development must be at the same time and economically attainable and naturally and culturally sensitive.

WTO Committee on Sustainable Development, agreed during the meeting in Thailand in March 2004, to improve the definition of sustainable tourism of WTO published in 1995 in Agenda 21 for the tourism industry. New conceptual definition places the emphasis on the balance between environmental, social and economic aspects of tourism, the need to apply the principles of sustainability in all aspects of tourism and refers to the general objectives such as reducing poverty. Guidelines and procedures related to sustainable tourism development are

¹⁰ Jafari, J. (1987): Tourism Models: The Sociocultural Aspects, *Tourism Management* 8(2), pp. 151-159.

¹¹ Ratz, T., Puczko, L. (1998): Rural tourism and sustainable development, Paper presented in the "Rural Tourism Management: Sustainable Options", Auchincruive, Scotland.

applicable to all forms of tourism in all types of destinations, including mass tourism and the various market niches as tourism segments. The principles of sustainability related to environmentally, economic and socio-cultural aspects of tourism development, a proper balance must be established between these three dimensions to guarantee long-term sustainability of tourism development.

Rural tourism and sustainability indicators

Rural tourism is often considered a form of tourism which is inherent in sustainability, it attracts few visitors, it does not need the development of large infrastructure, tourists are usually genuinely interested in local culture and tradition. One of the main attractions of rural tourism is the personal interaction with the local population, so that the guests and the hosts are able to exchange ideas and knowledge and, therefore, tourism can fulfill its role of "peace industry" as a means of general understanding.

However, if we analyze the rural tourism a little deeper, there are some doubts in relation to sustainability. The most important outcome that should be explored is the economic profitability of rural tourism services, because the demand is often seasonal, occupation capacity is low and investments that are necessary in order to create or improve facilities for tourists are often high. In most rural tourist destinations is unlikely that tourism can be the only source of income. Rural tourism can usually be only one of the possibilities of earning income in the region, and its role in sustainable development is to affect the performance of other economic activities (especially agriculture).

Tourism development also affects the socio-cultural characteristics of rural destinations, both in a positive and in a negative sense. As a positive influence, we should mention the following: rural tourism usually encourages better use of available resources (such as land, labor, capital, natural and cultural attractiveness), causes socio-economic changes, contributes to the protection and preservation of the rural heritage of the environment, providing more social contact of the local population and increasing their opportunities to learn about other cultures. Negative impact on tourism in rural areas are: changing and damaging rural landscape and natural and cultural values of the region, put additional pressure on the local community, changing their rhythm of life, jeopardizing their privacy or as a result has the nonauthentic

representation of local customs and traditions, which are tailored according to tourists desires.

Defining the strategy of integral development in any area, even in rural areas of Serbia agreed with the basic principles of sustainable development, in the foreground includes an objective economic valorisation and adequate involvement of the innovated and modern development process of all available resources of the local community. In short, it means completeness, rationality and sustainability of resource use, that is tailored to the market requirements and needs of the local population.

The impacts tourism on the tourist destination

Studies of tourism have traditionally addressed the impacts of this activity which are realized by changing ecological, socio-cultural and economic context of a space. Studying the ecological transformation mainly emphasize the changes that tourism realizes on the nature of some landscapes and ecosystems. Socio-cultural changes include analysis of how tourism is changing the local people, their culture and lifestyle, while economic studies show how tourism revised economic and industrial potential of destinations. In addition to the usual divisions (environmental, socio-cultural and economic) groups of influence can be further divided according to whether they realized a positive or negative impact type.

This confirms that the impact of tourism is complex in nature and should only be analyzed as such, while simplifying the given situation does not provide a realistic picture of the true extent of the impact.

Although the world public put at the center of its interests the problem of degradation and environmental protection, we can conclude that our knowledge about the impact of human activities is still insufficient. The knowledge of the impact of tourism is limited for several reasons:¹²

- Research in the area of influence are relatively undeveloped, a truly multi-disciplinary approach in this field has not yet been perfected;
- Research in the field of tourism's impact on the environment are prone to action only when something happens, so it is difficult to form a base with which it is possible to measure the changes;

¹² Stojanovic, B. (2000): Rural Architecture of Vojvodina as a tourism product, Tourism 4, Faculty of Science, Institute of Geography, Novi Sad, p. 62-65.

- It is not easy to separate the impacts on the environment from the effects of other economic activities or anthropogenic factors, as well as non anthropogenic causes, such as natural changes in the environment;
- It is not easy to separate the sources of environmental impacts realized by tourists from those caused by the action of the local population;
- The effects of tourism can be difficult to assess because the development of tourism implies cumulative effects;
- Proof of the unity of the environment is important for tourism too. For example, the effect of air pollution related to transport and tourism can contribute to the effects of acid rain destroying tropical forests;
- There is a lack of information concerning the state of resources before the tourism development, as well as the criteria by which change will be measured, and
- Strict familiarity of researchers only or certain primary resources, such as beaches and mountains, or ignoring some other area.

Tourism is a kind of environmental user and a specific challenge is that the consumer is not irreversible consumer of natural elements. Controlled development of tourism together with the construction of appropriate content, leads to the improvement of certain area.¹³

Tourism doesn't only have the duty of prevention of pollution and environmental degradation, but it must be focused on the improvement of resources, because it is largely based on the existence of these resources. Consideration of the relationship between man - environment (a tourist destination), is one of the most important problems in considering the tourist presentation of the environment. Interests of researchers are particularly focused on the negative impacts. Stanković says that for tourism, as it is needed by modern man and society, it is necessary to dispose with areas of the original physiognomy. Tourism is a kind of space consumer. With environmental degradation, quickly and easily and often irreversibly, tourist potential is lost. The prevention of degradation is closely related to the law, because the decisions for specific cases and locations must be summarized from general acts. The general orientation of society should be complementary to actions for the protection and improvement of the environment, both for the needs of the population of tourist region, and for the tourists who visit them. To this should be added that in addition to adopting specific legislation is

¹³ Jovičić, D. (2000): Tourism and Environment - the concept of sustainable development, Foundation Andrejevic, Belgrade.

necessary and that they are respected, because it often happens that the laws, regulations and decisions are well placed but do not have adequate implementation in practice.¹⁴ Modern tourism, conducted under the direction of sustainable development, is interested in global environmental change. This applies not only to those changes that are partly the consequence of the development of the tourism industry, but also to all the rest. This is important because tourism, particularly within small and selected groups, represents a form of learning that is suitable for the propagation of the importance of preserving the environment.¹⁵

The main macroeconomic indicators of the Republic of Serbia

The global financial crisis originated in the United States (US) in 2007 spread to the entire world. The same is started with turmoil in the housing market, the expansion of credit risk, which resulted in problems and high prices of petroleum products. For the first time in history such enormous decline in living standards in one state did not lead to the collapse of the socio-political system. Although the global financial crisis began in the United States it has spread and swung the whole world. Immediately afterwards, like a boomerang ,crisis is slowly overtaking Serbia.¹⁶ The appreciation of RSD and real wage growth were not covered by productivity growth, which lead to reduce of the competitiveness of the economy.¹⁷ All aforementioned affected primarily the slowdown in the economy of the Republic of Serbia. No matter what the impact of the crisis on the world economy was in 2008, immediately followed in Serbia it is disclosed in: The additional increase in unemployment; Reducing the already low volume of exports; The withdrawal of capital from Serbia; The reduction in foreign investment; Reducing the volume of industrial production; The reduced purchasing power of the population; and declining living standards and increasing poverty. At the table no. 1, the authors provide an overview of the main macroeconomic indicators of the Republic of Serbia in 2015 that give a cross section of the economy in the Republic of Serbia.

¹⁴ Stanković, S. (1998): Tourism and space - complementarity and collisions, Journal 'Tourism', no. 4, Institute of Geography, Faculty of Sciences, Novi Sad.

¹⁵ Stojanović, V. (2007): Sustainable development of tourism and the environment., Faculty of Science, Novi Sad, pp. 1-242.

¹⁶ M. Ljubić, (2009), The impact of the global financial crisis on the banking sector in Serbia, "Synergy 2009", University Synergy., Bijeljina, Bosnia and Herzegovina 06.March. 2009, Proceedings p.. 77-80.

¹⁷ Milanović M., Ljubić M., Muminović S., (2011), The impact of food price to the target inflation in the Republic of Serbia, the original scientific work, Agricultural Economics: Journal of the Institute of Economics, Institute of Agriculture in Belgrade, EP 2011 (58) 4, p. 547-562.

Table 1. *The main macroeconomic indicators of the Republic of Serbia in 2015*

The main indicators	
Population (million)	7.1
GDP (US\$ billion)	36.5
GDP per capita (US\$)	5119.76
GDP(PPP) per capita (US\$)	13671.43

Source: <http://reports.weforum.org/travel-and-tourism-competitiveness-report-2015/economies/#economy=SRB>

According to data collected by the authors of the work there, the macroeconomic picture shows moderate economic growth of the Republic of Serbia, with the reduction of macroeconomic imbalances. On the economic trends and the prospects of Serbia in the medium term will greatly affect the movement and prospects in the international economic environment, primarily in member countries of the Euro zone as its Serbian partners in trade and investment. IMF forecasts predict that unemployment will remain unchanged in most developed countries of the world and in a number of developing countries.¹⁸ Table No. 2 presents the macroeconomic indicators in the environment of Republic of Serbia from 2012 to 2015.

Table 2. *Macroeconomic indicators in the environment from 2012. to 2015.*

	2012	2013	2014	2015
Real GDP growth¹, %				
World -total	3,2	2,9	3,6	4,0
EU	-0,3	0,0	1,3	1,6
USA	2,8	1,6	2,6	3,4
Countries in development	4,9	4,5	5,1	5,3
The growth of world trade, %	2,7	2,9	4,9	5,4
Unemployment rate, %				
Euro zone	11,4	12,3	12,2	11,9
USA	8,1	7,6	7,4	6,9
Consumer prices, annual changes, %				
Developed economies	2,0	1,4	1,8	1,8
Countries in development	6,1	6,2	5,7	5,2
The growth of oil prices in dollars, annual changes, %	1,0	-0,5	-3,0	-5,9

Source: IMF, *World Economic Outlook, October 2013*

¹ World GDP calculated at purchasing power parity

¹⁸ http://demo.paragraf.rs/demo/combined/Old/t/t2013_11/t11_0076.htm Fiscal Strategy for 2014 with projections for 2015 and 2016 ("Off. Gazette of RS", no. 97/2013) Economic trends and prospects for the period 2014-2016. , the estimates of the international economic environment.

At the table no. 3, the authors provide an overview of the main economic indicators of foreign trade partners of the Republic of Serbia, with special emphasis on the Euro zone, Russia, Italy and Germany in the period 2012 to 2015.

Table 3. *Trade partners of Serbia - the main economic indicators*

	Country	2012	2013	2014	2015
Real GDP growth ,%	Italy	-2,4	-1,8	0,7	1,1
	Germany	0,9	0,5	1,4	1,4
	Euro zone	-0,6	-0,4	1,0	1,3
	Russia	3,4	1,5	3,0	3,5
Inflation , %	Italy	3,3	1,6	1,3	1,2
	Germany	2,1	1,6	1,8	1,8
	Euro zone	2,5	1,5	1,5	1,4
	Russia	5,1	6,7	5,7	5,4
Current account balance (% of GDP)	Italy	-0,7	0,0	0,2	0,0
	Germany	7,0	6,0	5,7	5,4
	Euro zone	1,9	2,3	2,5	2,6
	Russia	3,7	2,9	2,3	1,4
Consolidated fiscal balance,% of GDP	Italy	-2,9	-3,2	-2,1	-1,8
	Germany	-0,5	-0,4	-0,1	0,0
	Euro zone	-3,7	-3,1	-2,5	-2,1
	Russia	0,4	-0,7	-0,3	-0,6
Gross government debt, % of GDP	Italy	127,0	132,3	133,1	131,8
	Germany	81,9	80,4	78,1	75,2
	Euro zone	93,0	95,7	96,1	95,3
	Russia	12,4	14,1	14,6	15,1
Unemployment rate, %	Italy	10,7	12,5	12,4	12,0
	Germany	5,5	5,6	5,5	5,4
	Euro zone	11,4	12,3	12,2	12,0
	Russia	6,0	5,7	5,7	5,5

Source: *IMF, World Economic Outlook, October 2013.*

Since the world to the economic crisis affecting the whole world, and its effects are visible in the Republic of Serbia, in tables 4 to 8, are shown movement of macroeconomic indicators in the Republic of Serbia from 2005 to 2015.

Table 4. Gross domestic product and the cost of living from 2005 to 2015.

YEAR	2005	2006	2007	2008	2009	2010	2011	2012	2013	2014	2015
GDP at current prices - total, mil. RSD	1751371.2	2055198.1	2353065.6	2744913.2	2880059.0	3067210.2	3407563.2	3584235.8	3876403.4	3908469.6	4043467.8
GDP at current prices - per capita RSD	233375	277296	319046	373446	393407	420659	470884	497707	540902	548035	569873
ha average number of inhabitants in mid-year, in thousands.	7440.8	7411.6	7381.6	7350.2	7320.8	7291.4	7236.5	7201.5	7166.6	7131.8	7095.4
GDP - total, mil. USD	26188.9	30662.9	40331.0	49223.7	42684.6	39370.4	46463.7	40675.9	45512.1	44143.1	37145.7
GDP - per capita, USD	3520	4137	5464	6697	5831	5400	6421	5648	6351	6190	5235
GDP - total, mil. EUR	21103.3	24434.6	29451.6	33704.5	30654.7	29766.3	33423.8	31683.1	34262.9	33318.6	33491.0
GDP - per capita EUR	2836	3297	3990	4586	4187	4082	4619	4400	4781	4672	4720
Average exchange rate, EUR	82.9904	84.1101	79.9640	81.4405	93.9517	103.0431	101.9502	113.1277	113.1369	117.3060	120.7328
GDP real growth rates (%) ¹	5.5	4.9	5.9	5.4	-3.1	0.6	1.4	-1.0	2.6	-1.8	0.8
GNI, at current prices - total, mil. RSD	1709083.0	1991076.5	2276744.9	2665045.2	2833229.4	2999632.9	3208315.6	3460113.4	3715738.8	3749898.8	3842430.3
GNI - total, mil. USD	25556.5	29706.3	38989.8	47791.4	42020.1	38502.9	44565.0	39267.3	43625.7	42352.2	35298.9
GNI - total, mil. EUR	20593.7	23672.3	28472.1	32723.8	30177.5	29110.5	32058.0	30585.9	32842.9	31966.8	31826.0

Source: RSO, NBS, NSI u Republic Pension and Disability Insurance Fund

¹ From January 2011 applies a new methodology of calculating GDP.

In the reporting period from 2005 to 2015 can be seen a real drop in GDP, real growth rates (%). Namely in the year when the crisis hit GDP growth of 5.9% is present but a year later there was a drop of up to 5.4% and only a year later, the GDP was negative and amounted to -3.1%.

Also, in Table. 4 it can be seen that the population from year to year is in a significant reduction. So at the beginning of the observed period of 2005 the average number of mid-year population in thousands totaled 7440.8 and at the end of the period the average number of residents in thousands amounted 7095.4.

Table 5. *Industrial production (2015 = 100) from 2005 to 2015 in the Republic of Serbia*

YEAR	Total	Sectors			Inventories of finished products
		Mining Industries	Manufacturing	Electricity, gas and steam supply	
	1	2	3	4	5
2005	96.0	85.5	97.6	92.1	105.3
2006	100.0	89.0	102.0	94.3	107.8
2007	104.1	89.2	106.7	97.3	107.3
2008	105.6	93.9	107.9	99.3	110.6
2009	92.3	90.3	90.6	100.1	106.5
2010	93.4	93.8	92.9	95.7	98.2
2011	95.7	103.0	92.7	105.0	97.4
2012	93.6	103.1	91.9	97.5	93.0
2013	98.8	108.5	96.3	105.4	95.6
2014	92.4	90.4	94.9	84.2	97.6
2015	100.0	100.0	100.0	100.0	100.0

Source: *Republic Statistical Office*

In the reporting period from 2005 to 2015 can be seen a real drop in employees. Also, in Table. 8 can be seen that the average gross and net earnings increased by more than 100%. At the beginning of observed period it amounted to 25.514 RSD Gross wages and 17.443 RSD net earnings and at the end of the period amounted to 61.145 RSD Gross wages and 44.432 RSD net earning.

Table 6. *Employed and unemployed persons in the Republic of Serbia from 2005 to 2015.*

YEAR	Employment (in thousands), average		Earnings (RSD)		Real indices of unit labor costs in industry (2015 = 100) ³
	Number of employed persons ¹	The number of unemployed persons ²	The average gross wage, total	The average net wage, total	
	1	2	3	4	
2005.	2,171	888	25,514	17,443	-
2006.	2,115	913	31,745	21,707	-
2007.	2,085	850	38,744	27,759	112
2008.	2,082	756	45,674	32,746	111
2009.	1,985	747	44,147	31,733	111
2010.	1,901	744	47,450	34,142	103
2011.	1,866	753	52,733	37,976	97
2012.	1,866	762	57,430	41,377	101
2013.	1,865	775	60,708	43,932	97
2014.	1,845	767	61,426	44,530	103
2015.	1,883	743	61,145	44,432	100

Source: *Central Registry of Compulsory Social Insurance, National Bureau of Statistics, National Employment Service, the National Bank of Serbia.*

¹ Number of employees in legal entities and the number of entrepreneurs and their employees (excluding registered individual farmers); ² Since July 2004, in accordance with the law, by unemployed persons are considered only active unemployed but not all persons from National Employment Service register; ³ Unit labor costs calculated by the National Bank of Serbia.

Table 8 provides an overview of the indicators of the external position of the Republic of Serbia in the period 2005 to 2015. In the reporting period, the degree of openness of the economy (export + import) / GDP ranges from 70.8 in 2005 to 104.9 in 2015. On the basis of the data presented in the reporting period can be concluded that the degree of openness of the economy is to 34.1 higher at the end than at the beginning of the period.

Table 7. The foreign exchange market (in millions of euros) from 2005 to 2015

YEAR	Turnover on the foreign exchange market							
	Foreign currency				Foreign cash			
	Bank - National Bank of Serbia		SWAP	Bank-residents	Bank-nonresidents	Bank-authorized exchange, natural persons, legal persons ⁴	National Bank of Serbia - authorized exchange	Total (1 to 7)
Bank-to-bank	SPOT	3						
2005	2,032.1	-	-	11,828.3		1,879.5	2,018.7	19,732.9
2006	5,962.1	-	-	17,791.0		2,948.9	1,777.8	30,071.2
2007 ¹	22,319.0	708.7	-	37,922.3		4,379.8	1,179.3	66,509.0
2008	23,669.2	1,335.5	-	47,056.5		4,738.4	537.3	77,336.9
2009 ²	7,085.5	656.9	0.0	17,203.9	15,461.2	4,704.1	134.3	45,245.9
2010 ³	10,764.0	2,806.2	261.7	16,924.2	24,030.3	4,287.6	7.4	59,081.4
2011	19,536.5	135.0	364.5	19,962.8	36,409.8	4,559.5	0.0	80,968.2
2012	17,383.4	1,353.3	359.0	19,446.0	33,718.9	3,971.1	0.0	76,231.9
2013	9,150.6	1,050.0	248.0	18,933.6	32,940.9	4,366.2	0.0	66,689.3
2014	6,657.5	2,140.0	360.0	19,082.3	35,065.8	3,858.9	0.0	67,164.5
2015	8,077.5	1,420.0	1,101.0	19,748.0	42,753.0	4,283.3	0.0	77,382.9

Source: National Bank of Serbia.

¹ In June 2007, the National Bank of Serbia abolished the daily organizing of the Fixing meet, ² The National Bank of Serbia has data on trading in foreign currencies and foreign cash, classified by the transactions carried out with residents and transactions with non-residents, since September 2008., ³ The National Bank of Serbia in April 2010 stopped working with authorized exchange offices., ⁴ Natural persons - residents and non-residents; Legal entities - residents; Data also include the purchase and sale of foreign currency cash between licensed exchange, which use bank software to perform exchange operations, and natural persons.

Table 8. Indicators of external position of the Republic of Serbia in the period 2005 to 2015.

YEAR	2005	2006	2007	2008	2009	2010	2011	2012	2013	2014	2015
DEGREE OF OPENNESS OF ECONOMY (EXPORTS + IMPORTS) / GDP	70.8	77.4	80.1	82.6	69.0	79.8	82.7	89.8	92.6	97.7	104.9
MEMORANDUM: In million euros)											
GDP ¹⁾	21,103	24,435	29,452	33,705	30,655	29,766	33,424	31,683	34,263	33,319	33,491
External debt	12,520	14,291	17,382	20,982	22,272	23,509	24,123	25,645	25,644	25,679	26,294
External debt servicing	1,054	2,513	3,039	3,594	3,922	3,564	4,154	4,130	4,593	4,724	3,999
NBS foreign exchange reserves	4,922	9,020	9,634	8,162	10,602	10,002	12,058	10,915	11,189	9,907	10,378

Source: *National Bank of Serbia*.

1. The data are subject to corrections according to official sources

Table 9. The credit rating of the Republic of Serbia from 2005 to 2015

CREDIT RATING (Rating changes)	2005.	2006.	2007.	2008.	2009.	2010.	2011.	2012.	2013.	2014.	2015.
		July /May	Feb.	July	March/Dec.	Dec.	Nov.	March	Aug.	July	Jan.
S&P	BB- /stable	BB- /positive	BB- /stable	BB- /negative	BB- /stable	-	BB stable	BB- /negative	-	-	-
Fitch	BB- /stable	-	-	BB- /negative	-	BB- /stable	-	BB- /negative	-	B+ /stable	B+ /positive
Moody's	-	-	-	-	-	-	-	-	B1 /stable	-	-

Source: *National Bank of Serbia*.

In the table 9, the authors provide an overview of the credit rating of the Republic of Serbia in the period from 2005 to 2015, according to agencies for credit rating like: S & P, Fitch and Moody's. At the beginning of the observed period the credit rating agency Fitch was BB- / stable, and at the end of the period it has increased and is now a B + / positive. It can be concluded that the credit rating of the Republic of Serbia is positive and represents the fulfillment of one of the conditions for attracting investors and increasing economic development in the future.

Conclusion

Based on the above, it can be concluded that sustainable tourism should: make optimal use to environmental resources that constitute a key element in tourism development while maintaining essential ecological processes and helping to preserve the natural heritage and biodiversity; respect the socio-cultural authenticity of host communities, protects their built and modern cultural heritage and traditional values, and contribute to understanding and tolerance between cultures, and provide sustainable long-term business, creating social and economic benefits that are fairly distributed to all interest groups, including stable employment, opportunities for income generation and welfare of host communities, and contributing to poverty reduction.

Based on research conducted by the authors of the paper came following conclusions. By observing the macroeconomic picture of the Republic of Serbia, one can see a moderate economic growth of the Republic of Serbia, which results in increasing of macroeconomic imbalances. However further economic developments and future trends will greatly be affected by developments in the international economic environment, primarily in member countries of the Euro zone as the main partners of the Republic of Serbia in trade and investment. However, the number of inhabitants in the last ten years has decreased, but earnings have increased. Although the degree of openness of the economy increased 34.1 over the past ten years, the rate of unemployed persons is still high. According to data from credit rating agency, the Republic of Serbia has come from stable credit rating to the position of a positive credit rating in the last ten years, which greatly contributes in attracting investors and increasing economic development in the future. Based on the results shown in the paper, the authors conclude that the development of sustainable tourism is a key component of economic development of the Republic of Serbia.

Literature

1. Biljana Grujić, Marijana Ljubić, (2016): The Contribution of the Agrarian Budget to Rural Development in the Republic of Serbia – Case Study, in the Book ID: _9368_ Book Title: Rural Communities in the Global Economy: Beyond The Classical Rural Economy Paradigms, Nova Science Publishers, ISBN 978-1-53610-238-3, USA.
2. Fiscal Strategy for 2014 with projections for 2015 and 2016 ("Off. Gazette of RS", no. 97/2013) Economic trends and prospects for the period 2014-2016., The estimates of the international economic environment(http://demo.paragraf.rs/demo/combined/Old/t/2013_11/t11_0076.htm)
3. Jafari, J. (1987): Tourism Models: The Sociocultural Aspects, Tourism Management 8(2), crp. 151-159.
4. Jovičić, D. (2000): Tourism and Environment - the concept of sustainable development, Foundation Andrejevic, Belgrade.
5. Keane, M. J. and J. Quinn (1990): Rural Development and Rural Tourism, Social Sciences Research Centre, University College Galway, Galwa; Peters, K. et al (1994): Background Paper on Rural Tourism and Regional Development, Paper presented at the Central and East-European Federation for the Promotion of the Green-Soft-Rural Tourism Conference "Rural Tourism Development in Bulgaria and in the Balkan Countries", Karlovo.
6. Marijana Ljubic (2009) Impact of the global financial crisis on the banking sector in Serbia, "Synergy 2009", University Synergy., Bijeljina, Bosnia and Herzegovina 06.March. 2009, Proc. 77-80.
7. Marijana Ljubic (2012), Depreciation of the exchange rate in transition countries affected by the global economic crisis with regard to Serbia, Journal of Finance: scientific and professional magazine, the Ministry of Finance of the Republic of Serbia, God. 67, no. 1/6 (2012), p. 27-43.
8. Marijana Ljubić, Stevica Dedanski, 2014 Economic effects of rural tourism in Serbia, Belgrade: Center for Strategic Research of national security - Cesna B, International Conference on Rural Development, Kopaonik, 18 and 19 August

9. Milanović M., M. Ljubic, Muminović S., (2011), The impact of food price inflation to the target in the Republic of Serbia, the original scientific work, *Agricultural Economics: Journal of the Institute of Economics, Institute of Agriculture in Belgrade*, EP 2011 (58) 4, p. 547-562
10. Mowforth, M. and Munt, I. (1998): *Tourism and Sustainability. New Tourism in the Third World*, Routledge, London.
11. R. Maric, S. Štetić (2001): Integral development and environmental protection - the way to more modern and sustainable development of rural areas in Serbia, *Rural Tourism and Sustainable Development of the Balkans*, Kragujevac.
12. Ratz, T., Puczko, L. (1998): Rural tourism and sustainable development, Paper presented in the "Rural Tourism Management: Sustainable Options", Auchincruive, Scotland.
13. Stevica Deđanski, Marijana Ljubic (2014), Analysis of the effects of tourism on the balance of payments of the Republic of Serbia /. - Beograd: Centre for International Development Cooperation, 2014. Belgrade.
14. Stojanović, V. (2000): Rural Architecture of Vojvodina as a tourism product, *Tourism 4*, Faculty of Science, Institute of Geography, Novi Sad, pp. 62-65.

CHALLENGES OF CONTEMPORARY CAPITAL MARKET IN TRANSITION TO GREEN ECONOMY

Miljana Barjaktarović¹, Želimir Ilić²

Abstract

The climate change represents a serious international ecological problem for many years. Climate changes are, de facto, recognized worldwide as a serious threat to the financial markets. Financial experts all around the world apply different investment strategies to protect against the risks related to climate change. Spot transactions on the stock exchange are carried out on the spot market, where the contracted works are realized immediately after their conclusion while forward transactions are related to the purchase or sale of some assets in the future. The reason for establishing a CO₂ emissions trading should be sought in the fact that in the atmosphere annually is emitted enormous amounts of greenhouse gases. The volume of trading in CO₂ emissions from the beginning of trading recorded a steady growth. The largest volume of EU CO₂ emissions trading is done on the stock market. The conclusion is that the fall in the price of CO₂ emissions come as a result of the imbalance between supply and demand.

Keywords: *green indices, spot market, futures market, permits to emit CO₂, GHG - emissions of greenhouse gases.*

Introduction

Climate change for many years is a serious global environmental problem. The basis for this certainly represents excessive emissions of greenhouse gases (GHG).

¹Miljana Barjaktarović, Ph.D., Full Professor, Alfa BK University, Palmira Toljatija Street no. 3, 11070 Belgrade, Serbia, Phone: +381 11 2699 039, E-mail: miljana.barjaktarovic@alfa.edu.rs

²Želimir Ilić, MA, assistant professor, Alfa BK University, Palmira Toljatija Street no. 3, 11070 Belgrade, Serbia, Phone: +381 11 2699 039, E-mail: zelimir.ilic@alfa.edu.rs

Climate changes are, de facto, recognized worldwide as a serious threat to the financial markets. Financial experts all around the world apply different investment strategies to protect against the risks related to climate changes.

Green indices

Since climate changes are recognized worldwide as a serious threat to financial markets, financial experts around the world apply different investment strategies to protect against the risks associated with climate changes. Particularly this fact has led to the idea for the production and development of the Green Indices

Since it is referring to a global sustainable development, it is understandable that on the scene first appeared Dow Jones global sustainability indices DJSI.

The companies selected for that mentioned indices are determined on the basis of a comprehensive assessment of long-term economic, environmental and social criteria, as well as the trends of sustainability in a particular branch.

Only companies that lead their industries on the basis of this methodology are included in the index. Indices are formed in accordance with a methodology that allows investors appropriate benchmarks of sustainability of the resources over a longer period.

This group of indices includes a number of global and regional market indices, as well as global and regional blue-chip indices.

In January 2009 appears a new group of the MSCI Global Environment Index (Morgan Stanley Capital International Global Environment Index).

These indices are weighted by market capitalization, which is in free circulation and are designed in order to identify companies that are focused on performing their activity in an environmentally sustainable manner either directly by reducing consumption of natural resources and their efficient use of the transition to a green economy.

Table 1. *Composition of DJSI*

Geographical	Index
DJSI World	Dow Jones Sustainability World Dow Jones Sustainability World Enlarged Dow Jones Sustainability Emerging Markets
DJSI Regions	Dow Jones Sustainability Asia/Pacific Dow Jones Sustainability Europe Dow Jones Sustainability North America
DJSI Countries	Dow Jones Sustainability Australia Dow Jones Sustainability Canada Select 25 Dow Jones Sustainability Korea

Source: *Dow Jones Sustainability Indices Methodology*

<http://www.djindexes.com/sustainability/> (accessed: 01.11.2016).

Companies are ranked on the basis of estimated level of involvement and strategic commitment to key environmental issues such as alternative energy, clean technologies, sustainable water, green building and the prevention of pollution (MSCI Global Environment Indices Methodology, 2011). Low Carbon MSCI Indexes are the group of indexes intended to aid in identifying risks in connection with the transition to a green economy, that is, an economy with low emissions of carbon dioxide (CO₂). They refer to two aspects of possible exposure to carbon through emission of carbon dioxide, that is, on total reserves of fossil fuels. So, they are a kind of landmark for investors who have the intention to manage the risks associated with the transition to a green economy and are dedicated to the above-mentioned key environmental issues (MSCI Global Low Carbon Target Indexes Methodology, 2014). As the green economy has taken a key place in the economic development plan which is moving towards sustainable growth in the production of goods and provision of services, in the region have emerged and other green indices such as NASDAQ Clean Edge Green Energy Index (CELS), NASDAQ Clean Edge Green Energy Total Return Index (CEXX), E - carbix and others.

Spot and futures trading operations

Spot operations on the stock exchange are carried out on the spot market, where the contracted works are realized immediately after their conclusion (in practice up to five (5) working days from the day of the trading). The manner of the conclusion of the operation is carried out on the principle of delivery versus payment (DVP) or delivery versus delivery (DVD) where the surrender of the securities or delivery of goods are associated with receiving of payments or goods (Mishkin, Eakins, 2014).

Forward operations are relating to the purchase or sale of some assets in the future. This type of trade presupposes the existence of a buyer (who agrees to buy a subject of trade on a particular day in the future) and the seller (who is obliged to sell a subject of trade on a particular day in the future), and together with the price (which is defined at the time of conclusion of the contract) and the trading term (certain day in the future) makes the necessary in the elements of this work. In the case of goods, the quality of the goods (standard) and the place of delivery consists the additional elements (Mishkin, Eakins, 2014). The main function of futures markets is to reduce the risk of loss that occurs due to the high volatility of the price of the underlying assets (securities or commodities of the underlying futures contract). Certainly, the existence of those who clones the risks provokes reporting of participants who do not have so much aversion to risk and venture into the "game" with the aim to make a profit on the basis of an assessment of the expected growth or falling prices of assets that area subject to trading. Depending on the motives that lead participants to enter the futures market, we distinguish the hedgers and speculators. While the first buys/sells the contracts to protect against loss due to changes in price, the latter their jobs base on the successful prediction of price movements in the future.

Table 2. *Motives for buying and selling of future contracts*

Participants	The motives for buying of future contracts	The motives for selling of future contracts
Hedgers	Price fixing and protection against the growth of prices of goods	Price fixing and protection from drop in prices of goods
Speculators	Profit derived from the expected growth of prices of goods	Profit derived from the expected drop in prices of goods

Source: *Dugalić, Štimac, 2009.*

Forward contracts

In forward contracts, the price for the relevant assets is first defined and the time of transfer of funds in the future. There is also the option that in the time of determining the price of underlying assets immediately to be paid in the contract that will be delivered in a subsequent period (purchase of corn for delivery in March corn in October - Contracts on the

green) (Šoškić, Živković, 2011). Forward contracts are futures contracts, however, are not standardized so are considered individual contracts and usually, are concluded in the OTC market and are characterized by risks related to payment or performance of the contract. In the event that any of the parties for the duration of forward contracts (from the moment of signing and execution of forward contracts), estimated to be at a loss in the case of execution of the contract, has the ability to pre-expiration of the contract with the same contractor sign a forward contract in opposite meaning. Thereby, an initial contract is annulled and the difference in price of two opposite forward contracts is paid in cash to the counterparty. Practically, the counterparty due to un favorable price movements of opposite transaction cancels the original contract and reduces loss. Exactly this process is essentially the first step in the construction of more complex forms of freight transport.

Futures contracts

Futures contracts are standardized forward contracts that are characterized by high liquidity, a priori about the safety performance of the contract due to the existence of a clearing house as a guarantee of execution of the transaction. So, agree on an organized stock exchange and in addition to detecting the direction of movement of the price of the underlying assets backing the contract and the transfer of risk, providing the possibility of speculative activity and earnings for participants with reduced risk aversion. Futures contracts may be a commodity and financial (currency, interest rate, futures on market indexes and derivative securities) (Mishkin, Eakins, 2014). By purchasing futures are predicted price movement in the underlying assets and that there is no basic intention that these assets to be received/delivered. And if it is possible, in practice, only about 2% of all futures contracts and implemented. (Mishkin, Eakins, 2014).

Trading system of CO₂ emissions

Climate change is a serious global environmental problem. The reason for this phenomenon represents excessive emissions of greenhouse gases (GHG), aimed to reduction and in the world have been undertaken a number of activities including the first Montreal Protocol (1987) of compounds that deplete the ozone layer. This document itemizes the substances that deplete the ozone layer and which are labeled as controlled substances and the control measures that each signatory

country lies in the obligation to carry out measurements in the form of billing levels in the twelve-month period from the time of the measurement (Zakon o ratifikaciji Montrealskih protokola o supstancama koje oštećuju ozonski omotač, 1990).

Only ten years later, with the signing of the Kyoto Protocol (1998) - an international agreement with binding force, the phenomenon of excessive emissions of greenhouse gases is being placed in the focus of the world public. In addition to reducing cumulative emissions, the goal of signing the Kyoto Protocol was the setting of the system to achieve the target emissions of States Parties included in Annex B (Kyoto Protocol to the United Nations Framework Convention on Climate Change, 1998). System mechanisms of the Kyoto Protocol are: Joint Implementation Mechanism-JI, Clean Development Mechanism-CDM, and Trading Emissions-ET. The mechanism of joint implementation (JI), as defined in Article 6 of the Kyoto Protocol allows Parties to invest in projects in other countries exercise their right to emission reduction units-ERU. Joint Implementation is offering participants a flexible and cost-effective means to meet part of their obligations under the Kyoto Protocol, while to the host country is an additional benefit in the form of foreign investment and technology transfer (Joint Implementation-JI, 1998).

Clean Development Mechanism (CDM), defined in Article 12 of the Kyoto Protocol allows developing industrial countries to be engaged in projects whereby the industrialized countries are entitled to the Certificate of emissions reduction the implementation of projects to reduce emissions in developing countries. This mechanism stimulates sustainable development and emission reduction, giving industrialized countries some flexibility in how they meet their target objectives (Clean Developed Mechanism – CDM, 1998). International Emissions Trading (ET) - GHG emissions-new goods. Signatory countries (Annex B of the Kyoto Protocol) have undertaken to reduce or limit emissions in their own countries. These targets have been named as levels of allowed emissions or as assigned amounts. The assigned amounts are licenses into gas emissions (Assigned Amount Units AAU) (International Emissions Trading, 1998). Thanks to this fact in the market participants appeared to have a surplus "carbon credits", as well as participants who have the same deficits. At this point begins the development of trade permits to emit CO₂ or CO₂ emissions market development. Emissions trading (ET) unlike of the first two mentioned mechanism is not based on the implementation of the projects but already on the establishment of the market mechanism and the development of market efficiency. The

reason for establishing a CO₂ emissions trading should be sought in the fact that in the atmosphere annually is emitted an enormous amount of GHG emissions. If we look at the total amount of CO₂ emissions on a global level, during the observed period from 1975 to 2015 (Table 4), we shall conclude that the volume kept increasing even after 2000 (except in 2009). We remind that earlier was scientifically confirmed that in order to prevent climate change, emissions must be reduced by 80% by 2050 (Global emissions of carbon dioxide, 2016).

Table 3. Emissions of greenhouse gases in the world in the period from 2004 to 2013

Country/Period	2004	2005	2006	2007	2008	2009	2010	2011	2012	2013
EU (28)	4,944,709.96	4,903,304.13	4,860,996.97	4,854,236.66	4,704,190.31	4,347,090.73	4,471,947.5	4,314,550.44	4,250,374.61	4,158,830.79
EU (15)	4,067,764.57	4,029,236.03	3,985,230.2	3,936,008.92	3,817,554.22	3,532,671.61	3,626,890.92	3,472,488.18	3,434,952.51	3,373,392
Belgium	146,096.85	141,957.11	136,890.26	132,537.41	135,078.57	122,093.22	129,519.61	119,269.73	115,378.74	115,667.08
Bulgaria	54,918.23	55,298.43	56,116.28	59,752.02	58,660.8	49,566.5	51,866.02	57,114.84	52,036.14	46,568.72
Czech Republic	140,258.24	137,987.47	142,124.52	145,724.8	137,456.38	127,650.88	130,330.63	127,625.63	123,560.41	120,402.15
Denmark	75,944.6	71,585.95	80,462.86	72,711.41	64,806.17	72,865.73	65,486.4	58,192.75	54,869.74	56,974.19
Germany	1,008,162.72	980,493.62	987,631.99	960,301.06	955,688.98	888,910.19	924,995.07	905,616.09	912,347.09	934,978.99
Estonia	16,306.17	13,498.77	11,488.66	13,520.72	12,024.91	10,014.93	14,970.68	17,322.36	17,944.74	21,411.12
Ireland	73,861.32	74,764.87	75,770.31	74,406.24	73,309.93	65,149.43	67,186.28	65,684.59	65,143.67	62,627.98
Greece	129,960.16	133,679.17	129,869.77	134,212.06	128,944.57	122,357.85	116,363.65	113,227.63	109,804.56	101,791.95
Spain	394,460.75	408,425.76	400,723.93	406,659.36	373,290.01	335,579.49	323,053.85	321,415.11	314,961.29	287,954.1
France	504,801.62	505,743.27	491,741.17	482,839.9	477,126.98	462,255.43	476,977.49	445,654.8	440,634.59	443,517.88
Croatia	23,727.54	23,732.64	24,200.23	26,092.44	24,722.21	22,559.06	22,065.71	22,531.52	20,468.71	19,367.59
Italy	551,265.77	547,588.78	537,183.35	551,818.07	520,238.89	467,772.75	472,283.31	465,828.52	448,114.69	403,185.93
Cyprus	8,701	8,948.58	9,179.75	9,609.72	9,743.35	9,554.34	9,284.26	9,054.78	8,491.42	7,673.14
Latvia	6,399.79	6,941.58	6,453.24	7,567.4	6,759.39	9,625.27	12,778.46	11,642.5	10,549.81	10,765.95
Lithuania	15,074.14	18,012.23	17,654.37	20,668.32	15,147.84	8,993.84	9,698.05	10,264.41	12,322.09	9,982.12
Luxemburg	12,540.23	12,782.14	12,736.84	12,142.11	11,817.19	11,251.89	11,830.94	11,862.9	11,301.4	10,695.71
Hungary	72,994.12	70,360.89	71,482.99	69,389.74	66,183.37	61,219.77	61,488.95	60,220.18	55,681.36	53,990.26
Malta	2,862.61	2,952.32	2,974.61	3,071.34	3,048.98	2,986.17	3,022.53	3,074.72	3,168.43	2,786.47
Netherlands	225,446.61	219,377.71	215,399.79	214,139.74	213,551.78	208,542.04	219,714.98	206,083.59	202,443.58	202,043.55
Austria	81,849.22	81,353.72	83,907.23	80,991.21	82,009.28	75,343.83	78,621.27	76,143.12	73,776.93	74,621.03
Poland	353,003.16	353,914.31	352,688.54	381,590.96	374,709.21	358,105.34	379,924.1	370,112.09	364,306.67	357,304.53
Portugal	77,306.3	88,245.81	73,720.64	67,627.68	63,925.06	61,065.44	58,947.63	55,255.25	56,801.04	55,881.89
Romania	126,491.35	122,335.58	123,665.75	123,198.33	117,908.64	100,124.54	93,527.93	98,032.77	96,358.43	85,989.86
Slovenia	13,012.24	13,307.48	13,521.14	15,247.33	16,421.49	14,509.77	14,606.28	14,689.07	14,143.49	13,419.98
Slovakia	43,196.79	46,777.82	44,206.68	42,794.62	43,849.52	39,498.73	41,513	40,377.38	36,390.4	35,777.88
Finland	52,609.27	39,683.54	44,684.94	50,838.04	44,214.24	28,015.85	49,028.45	41,848.37	34,492.4	42,609.18
Sweden	29,091.56	28,543.27	26,057.69	19,342.25	18,120.99	14,536.69	21,174.47	21,940.27	14,295.28	14,222.71
United Kingdom	704,367.58	695,011.31	688,459.41	675,442.37	655,431.58	596,941.79	611,707.52	564,665.45	580,587.54	568,819.82
Island	15,717.18	15,678.4	16,381.22	16,744.24	17,252.19	16,891.4	16,654.7	16,435.08	16,478.06	16,431.55

Source: Eurostat, European Environment Agency (EEA), (2015): <http://ec.europa.eu/eurostat> (accessed: 01.15.2016).

Much of the world's emissions come from a small number of industrialized countries (the US, EU countries, Japan, Canada, the Russian Federation). In connection with the initiated, the conditions for the emergence of the market of CO₂ can be found in 1990, and the period when the protection and preservation of the environment are coming into the limelight (Aziakou, 2006).

Table 4. *The total quantity of CO₂ emissions on a global level in the period from 1975 to 2015*

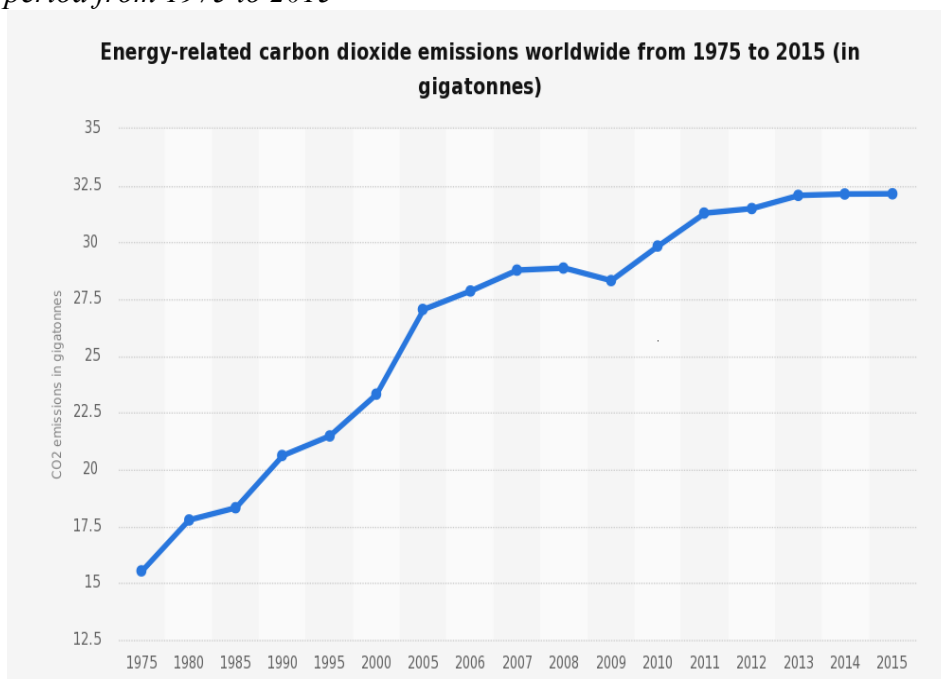

Source: *Energy - related carbon dioxide emissions worldwide from 1975 to 2015 (in gigatonnes).* (2016).Statista.com.

<https://www.statista.com/statistics/526002/energy-related-carbon-dioxide-emissions-worldwide/>.

Emissions market of CO₂

Exchange market permit for CO₂ emissions in the European Union comes down to a few exchange markets, such as the London Stock Exchange ECKS / IPE, Germany EEKS, Austrian EKSAA, CLIMEKS in the Netherlands, in France or NORDPOOL stock exchange which is a common stock exchange of Scandinavia (The EU Emissions Trading System, 2016).

Over the counter market (OTC) where the trade pollution permits perform by telephone and via the information system using standardized contracts or agreements between the buyer and the seller. The volume of trading in CO₂ emissions from the beginning of trading recorded a steady growth. The largest volume of EU CO₂ emissions trading is carried out in the stock market (The EU Emissions Trading System, 2016).

Table 5. *Trading in CO₂ emissions (in million tons)*

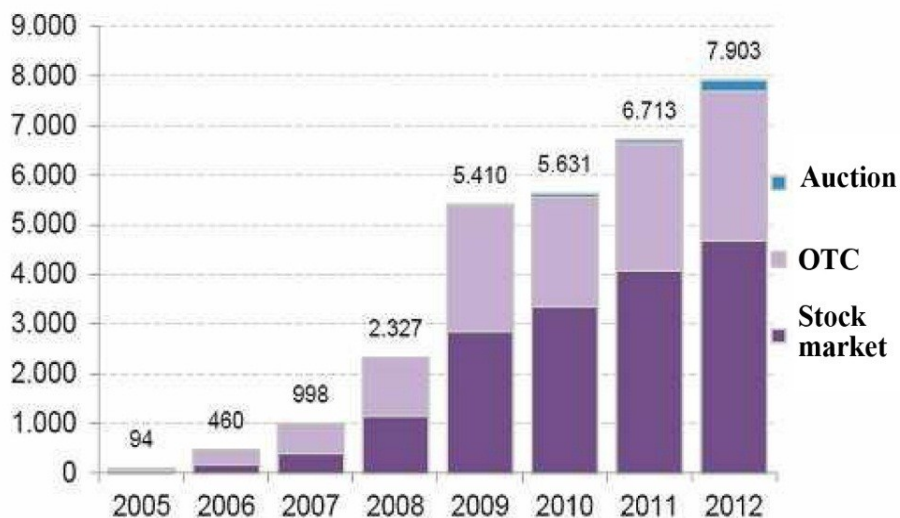

Source: *European Commission. The EU Emissions Trading Systems (EUETS). Brussels.*

Since the entire system is designed to reduce annual emissions compared to 1990, GHG emissions alone must be used within one emission year. Stock Exchange transactions of CO₂ emissions can be transactions in the spot and forward markets. On the spot market, payment and delivery of the license shall be performed immediately or within a short period after the completion of the transaction. On the futures market, there is forward trading, where there are payment and delivery of licenses suspended for a specific date in the future and which is defined at the time of trading. In addition to forwards, the forward market may be traded and by options contracts which participants give the right but not the obligation on the completion of the transaction date and at the price specified in the present on a specific date in the future (Greenhouse Gas Market Overview, 2016) Organization of the system requires that there is a sufficient number of participants in the trading process and a sufficient number of buyers and

sellers permit. Low transaction costs for trade licenses will stimulate trade. The existence of a strong regulatory system is a condition without which it is impossible to maintain the market stable. The entire trade system depends on a number of activities (issuance of emission license, control, monitoring, verification, and maintenance of the register of reducing emissions) (Carmona, Hinz, Porchet, 2009). In the world, there are several systems for trading of CO₂ emissions, of which the most famous is for us and the most important EU ETS (European Union Emissions Trading System).

EU ETS CO₂ emissions trading scheme

EU Emissions Trading System (EU-ETS) is a cornerstone of the European Union in the fight against climate change, as well as a means to reduce emissions cost-effectively. EU-ETS was officially established on 1 January 2005 (Braun, 2009). EU-ETS works on the principle of setting limits on total emissions from high-emitting sectors, which each year with the aim to reduce in 2020, emissions from sectors covered by the EU ETS system are 21% lower compared to 2005 (The EUE missions Trading Scheme, 2016).

The realization is carried out in three phases (Duerr, 2007). The first phase of implementation lasted from 2005 to 2007. It included about 12,000 enterprises which accounted for 40% of greenhouse gas emissions in the EU. The second phase lasted from 2008 to 2012. One of the objectives was to expand the overall process, however, the economic crisis that has burst out in this period led to reduced demand for pollution permits. The market showed a surplus of permits which resulted in a decline in the price of emission permits. Penalties for those plants that their emissions were not able to cover the emission permits, amounted to 100 €/t CO₂. A system of trading in 2012 was established in the airline's companies. The third phase is in progress (2013-2020). Longer term trading should contribute to the greater predictability of the market, which is essential for promoting long-term investment in emission reduction. A trading system can be set in two ways: "cap & trade" or "baseline & trade". The essence of cap & trade system is that the competent body sets a limit emissions of all broadcasters covered by the system of trade and on the basis of this restriction puts constraints unique to each separately. The baseline & trade system for all companies is set as a limit for the gaseous emissions. EU ETS works on a "cap & trade" system. CAP is the total amount of gases that can be emitted by the emitter. CAP over the time decreases

leading to the overall reduction of emissions (Cook, 2009). In the context of the CAP, companies receive emission units with which they can trade and the possibility that the international market buys a particular number of credits contributing from projects that contribute to reducing emissions (Braun, 2009). Limiting the total number of emission units available on the market prevents a drop in their values. At the end of the accounting year, companies must provide sufficient emission units to justify their total annual gaseous emissions. In case the company successfully reduced annual emissions, may retain excess emission unit for themselves or to sell them to another company (Voss, 2007).

Discovering the price of emission permits on the market of the CO₂

Since its establishment till today, the CO₂ emissions market has experienced rapid development. The total value of these markets in 2011 amounted more than \$ 175 billion, which is more than 20 times compared to 2005 (State and trends of carbon markets, 2012).

Figure 1. Price trends of emission licenses 2005-2013.

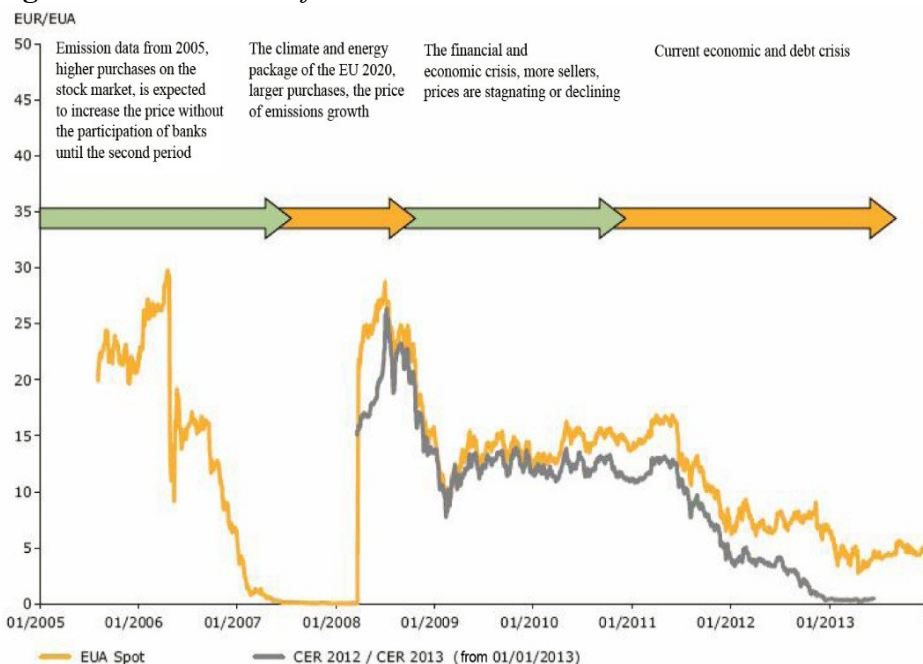

Source: (Stojanović, 2016)

The price of emission licenses in gases grew steadily until the first quarter of 2006 and reached its price of 30€/ tCO₂. Then suddenly drops to 10 €/tCO₂. After the publication of the report on emissions states (during the first period), it was observed that the national allocation plans of emission licenses granted too many permits. Therefore, the EUA price continues to drop, so that in the first quarter of 2007 dropped to 1,2 €/ tCO₂(minimum in June of 0,13 €/ tCO₂) (Investirajte svoj novac, 2016). In the next period comes to growth. In January 2010 it amounts to 12,85 €/ tCO₂, and for the year 14,97 €/ tCO₂. At the beginning of the last quarter of 2011 again it leads to decline and the beginning of 2012 amounted to 8,06 €/ tCO₂. With smaller slope and in the coming years the price of emission permits slightly declines so that in December 2014 amounted to 7,34 €/tCO₂ (Koch, 2014).

The conclusion is that the fall in the price of CO₂ emissions come as a result of the imbalance between supply and demand. The reasons for these are the set annual emission limits, which are de facto, higher than the emissions of the company; decreased the ability to use international credits in the EU ETS due to the surplus and the decline in industrial production due to the great economic crisis (What's needed to fix the EU's carbon market Recommendations for the Market Stability Reserve and future ETS reform proposals?, 2014).

In the scientific and professional public were conducted numerous studies on the prices of emission permits. They studied the impact on drivers of price related to formation price of emissions permits, however, the same had limited impact (Alberola, Chevalier, Chèze, 2008).

Part of the author believes that the price of emission permits is corresponding to the price of energy, extreme weather conditions, and economic growth (Bunn, Fezzi, 2009), while others favoured an approach to time series (Milunovich, Joyeux, 2010).

Finally, Mansanet - Bataller etc. analysed the factors that affect the price of emission permits. Using data on the spot and futures prices from Phase I, they have shown that there is a correlation between the price of fossil fuels and the price level of emission permits (Mansanet - Bataller, Pardo, Valor, 2007). Alberola and others also confirmed this result and come to the conclusion that extreme time events have a major impact on the prices of emission permits (Alberola, Chevallier, Chèze, 2008).

Conclusion

Striving for innovation and the application of clean technologies are essential to solving the problem of global warming. EU Emissions Trading System (EU-ETS) is a cornerstone of EU policy in the fight against climate change, as well as the means to economically reduce emissions.

Modern commodity stock exchanges are organized as the modern commercial institutions on which runs a different kind of goods with strictly defined quality and in large quantities. The point is that transport is efficient, cheap and fast. The only institution of its kind in the Republic of Serbia is the Commodity Stock Exchange in Novi Sad, which organizes auctions on the principle of stock market operations but only on the spot market in a way that otherwise, operates stock markets worldwide. In any case, there is the lack of real securities backed by the goods.

The proposed Law on commodity exchanges, for the first time, treats securities backed by the goods or goods as stock material and regulates the issues of commodity exchanges. In any case, it is expected the possibility of trading with commodities and futures contracts and the introduction of futures markets in contrast to the existing prompt markets. The process of introducing different types of instruments on the futures market is determined by their complexity so you should first expect to find the market forwards and then gradually be expected, and power futures and spots. However, trading options contracts can be expected only in the higher levels of development of the financial market in the Republic of Serbia. Experience shows that the introduction of financial and commodity derivatives traded on organized markets are preceded by the traded off to these instruments. Realistically, from the current perspective, the establishment of futures markets with the necessary infrastructure, rules and regulations seem quite far in our country.

The conclusion is that the drop in the price of CO₂ emissions in the world market came as a result of the imbalance between supply and demand. The reasons for this are set annual emission limits, which are de facto, higher than the emissions of the company, then decreased the ability to use international loans and a decline in industrial production due to the economic crisis.

Literature

1. Alberola, E., Chevallier, J. & Chéze, B. (2008): *The EU emissions trading scheme: The effects of industrial production and CO2 emissions on carbon prices*. Open Access publications from Universite Paris - Dauphine urn:hdl: 123456789/4223, Universite Paris – Dauphine.
2. Aziakou, G. (2006). *Britain Urges Global Carbon Trading to Spur Eco - Healthy Growth*, Terra Daily, 21st April, <http://www.terradaily.com/reports/> (accessed 01.15..2015.)
3. Bunn, D.W. and Fezzi, C. (2009): *Structural Interactions of European carbon trading and energy prices*, Journal of Energy Markets, 4 (2), pp. 53-69
4. Braun, M. (2009): *The evolution of emissions trading in the European Union—there of policy networks, knowledge and policy entrepreneurs*, Organizations and Society, vol 34, pp. 469–487.
5. Carbon Market Watch Policy Briefing (2014): *What’s needed to fix the EU’s carbon market Recommendations for the Market Stability Reserve and future ETS reform proposals?* pp. 3-4.
http://carbonmarketwatch.org/wp-content/uploads/2014/07/ETS-POLICY-BRIEF-JULY-2014_final_1.pdf accessed 06.12.2016)
6. Carmona, R., Fehr, M., Hinz, J. And Porchet, A. (2009): *Market design for emission trading schemes*, SIAM Review, pp. 465 -469.
7. *Clean Developed Mechanism – CDM*. (1998): United Nations http://unfccc.int/kyoto_protocol/mechanisms/clean_development_mechanism/items/2718.php
8. Cook, A. (2009): *Emission rights: From costless activity to market operations*. Organisations and Society, 34, pp. 456–468.

9. Duerr, D. (2007): *EU Emission Trading*, Fact Book, Inagendo Gmbh, Niederkassel.
10. Dugalić, V., Štimac, M. (2009): *Osnove berzanskog poslovanja*. Stubovi kulture, Beograd.
11. European Commission. (2016): *The EU Emissions Trading Scheme*. <http://www.ec.europa.eu> (accessed: 08.29.2016).
12. Eurostat, European Environment Agency (EEA), (2015): <http://ec.europa.eu/eurostat> (accessed: 01.15.2016).
13. Greenhouse Gas Market Overview. (2016): *IETA Climate Change Market Solutions*. <http://www.ieta.org/ghgmarket2016>
14. Hintermann, B. (2010): *Allowance price drivers in the first phase of the EUETS*. *Journal of Environmental Economics Management*, 59, (1), pp. 43–56.
15. *International Emissions Trading*. (1998): Kyoto Protocol to the United Nations Framework Convention on Climate Change, Kyoto, Japan.
http://unfccc.int/kyoto_protocol/mechanisms/emissions_trading/items/2731.php
16. *Investirajte svoj novac* (2016): Carbon Emissions Historical Data Chart <http://www.investing.com/commodities/carbon-emissions-historical-data> (accessed 01.04.2015.)
17. *Joint Implementation - JI*. (1998): Kyoto Protocol to the United Nations Framework Convention on Climate Change, Kyoto, Japan
unfccc.int › Kyoto Protocol › Mechanisms
18. Koch, N. (2014): *Dynamic linkages among carbon, energy and financial markets: a smooth transition approach*, *Economics*, 46 (7), pp. 715–729.

19. Mishkin S.F., Eakins, S. (2014): *Finansijska tržišta i institucije*, Mate, Beograd.
20. *MSCI Global Low Carbon Target Indexes Methodology*. (2014): https://www.msci.com/eqb/methodology/meth_docs/MSCI_Low_Carbon_Target_Indexes_Methodology.pdf
21. MSCI Global Environment Indices Methodology https://www.msci.com/eqb/methodology/meth_docs/MSCI_Global_Environment_May2011.pdf
22. Mansanet-Bataller, M., Pardo, A. & Valor, E. (2007): *CO2 prices, energy and weather*. The Energy Journal, 0 (3), pp. 73-92.
23. Milunovich, G. and Joyeux, R. (2010): *Testing market efficiency in EU carbon futures markets*, Financial Economics, 20 (10), pp. 803-809.
24. *Energy-related carbon dioxide emissions worldwide from 1975 to 2015 (in gigatonnes* (2016): Statista.com. <https://www.statista.com/statistics/526002/energy-related-carbon-dioxide-emissions-worldwide/>
25. *Global emissions of carbondioxide* (2016): The Statistics Portal. <http://www.statista.com/statistics/global-co2-emissions/>
26. Стојановић, Д. (2016): Развој терминског тржишта и трговања зеленим производима у ф-ји раста тржишне вредности компанија, Докторска дисертација, стр. 51.
27. The Global Hub For Carbon Comerce. (2010): *Greenhouse Gas Market Overview*. <http://www.co2en.cat/ca/>
28. United Nations. (1998): *Kyoto Protocol to the United Nations Framework Conventionon Climate Change*, Kyoto, Japan.

29. Voss, J. P. (2007): *Innovation processes in governance: The development of emissions trading as a new policy instrument*. Science and Public Policy, 34, pp. 329–343.
30. World Bank. (2012): *State and trends of carbon markets*. World Bank Carbon Finance Unit Publications and Reports
31. Zakon o ratifikaciji Montrealskih protokola o supstancama koje oštećuju ozonski omotač („Sl. List SFRJ – Međunarodni ugovori“, br. 16/90 i „Sl. list SCG – Međunarodni ugovori“, br. 24/2004)
32. Šoškić D., Živković B. (2011): *Finansijska tržišta i institucije*, CID Ekonomski fakultet, Beograd.

IMPLEMENTATION OF IMPROVED LC MODEL IN SERBIA IN ACCORDANCE WITH THE BEST EU PRACTICE

Nenad Gvozdrenović¹

Abstract

The main goal was implementation of improved Land Consolidation (LC) model in Serbia. In paper the focus will be on novelties which were introduced and implemented in 7 pilot LC projects in accordance with best EU practice. Also very important part is lessons learned which were collected during the implementation phase and used as inputs for drafting of LC by laws within the Law on agriculture land. The structure of paper will be present in following topics: introduction, improvement of the LC model, partners involved, goal, novelties and improvement, conclusion-lessons learned, follow up phase LM3.

Key words: *Land Consolidation, Good Governance, Serbia, EU best practice, Agriculture, Rural Development.*

Introduction

The European Union and Government of the Federal Republic of Germany decided to support Serbian Ministry of Agriculture through IPA project improvement of agriculture land management on state and local level in Serbia. The project had 4 components. The management of state owned agricultural land was improved by providing an IT system which will allow for more efficient and transparent procedures especially for the leasing of state land. Several pilot municipalities were included in the development process of the IT system, which will now be used to elaborate yearly programs for the leasing of state land.

Seven pilot projects for land consolidation were implemented, especially in southern and eastern parts of Serbia. The overall area of land

¹ Ma Nenad Gvozdrenović, Project Manager for Strengthening Municipal Land Management in Serbia, Deutsche Gesellschaft für Internationale Zusammenarbeit (GIZ) GmbH, Str. Obilićev venac 18-20, floor V, 11000 Belgrade, Serbia, phone: + 381 11 32 81 589, e-mail: nenad.gvozdrenovic@giz.de

consolidation was more than 5000 ha. Of that, more than 3300 ha were added during the projects on demand and with financing of the partner municipalities. The average size of the land parcels in the completed projects rose between 100% (smallest individual project) and more than 400% (biggest project) respectively. This will allow for better and more productive agricultural production as well as improved income of farmers. Main innovations introduced into the land consolidation process in Serbia were improved participation of land owners and farmers, more transparent land valuation as well as environmental assessment.

The problem of land abandonment was addressed by elaborating a procedure for identification of abandoned land plots and a process to getting such lots back into use. During the project of LC at least 55 ha were put back into use.

The above mentioned topics were also addressed in draft by-laws elaborated for the Law on Agricultural Land. These by-laws will secure sustainability of the project outcomes and provide for improved framework conditions for the management and use of agricultural land in Serbia.

Besides the main beneficiary, the Directorate of Agricultural Land (DAL) of the Ministry of Agriculture and Environmental Protection, other important stakeholders of land management in Serbia, such as the Republic Geodetic Authority (RGZ) and the Standing Conference of Towns and Municipalities were included in project implementation.

Improvement of the LC model

During the implementation of the land consolidation according the Law on Agriculture Land (LAL), it has been identified that there is a need for improvement of institutional level and legal framework. Fragmented land parcels with irregular shape, often not accessible by field and track roads, underdeveloped infrastructure, outdated cadaster records resulting in a low agricultural productivity are also a big problem in Serbia, especially in the southeastern part of the country. For the aforementioned reasons and upon the request of the Republic of Serbia, the European Union and the Government of the Federal Republic of Germany decided to support the Serbian Ministry of Agriculture through IPA project named “Rural development: Effective Land Management/Strengthening Municipal Land Management in Serbia”, implemented by the Deutsche Gesellschaft für Internationale Zusammenarbeit (GIZ), with the aim to improve land

management in Serbia at the national and local level as a part of rural development measures. There were 7 LC pilot projects within this project. The lessons learned from pilots should be used in order to improve the traditional LC model in Serbia, particularly the existing legal framework and land consolidation implementation procedures. The decision to place pilot projects in Southeastern and Central Serbia was based on the fact that this region has a problem with prevalingly fragmented plot structure (average size of parcel is 0,11ha) and a lack of infrastructure.

Partners involved

Key partners of the project were the Ministry of Agriculture and Environmental Protection –in particular its Directorate for Agriculture Land (DAL), 7 municipalities in Southeast Serbia, to be specific Municipalities of Paraćin, Boljevac, Knjaževac, Svrlijig, Pirot, Negotin and Žitorađa. In addition, the cadastral authority at the national and local level (Republic Geodetic Authority) was also a partner of the project.

Goal

The main goal was improvement of Serbian land consolidation model in accordance to the EU best practices.

Novelties and improvement Participation, visibility and transparency

Awareness of the local population, especially farmers, for the needs and chances that land consolidation offers is of the utmost importance for successful implementation of land consolidation pilot schemes. Public hearings, workshops, promotional and awareness raising campaigns were organized to meet this purpose. The additional support to the process was given by printing flyers and brochures as well as by interviews in newspapers and TV. The project also made a documentary about all important phases in implementation of land consolidation and introduced novelties.

Establishing Criteria and Selection of Pilot Projects

The project and the main project partner – Ministry of Agriculture and Environmental Protection (Directorate of Agriculture Land) have jointly visited 22 municipalities in the southeastern region of Serbia in order to select 7.

The selection of pilot municipalities was based on the comparison of criteria (support from local authorities, willingness of community members to participate, suitability of the area proposed for land consolidation, fragmented, scattered and abandoned parcels) and indicators collected through questionnaires, field visits and discussions with workshop participants.

Implementation of Environmental Impact Assessment (EIA) in LC process

The Plan of Common and Public Facilities present infrastructure frame for the upcoming grouping of new parcels (PCPF) and were used to introduce EIA in LC process. Activities which influence transformation in the land consolidation process should be environmentally acceptable. Significant or lasting negative effects should be avoided. Protection of valuable habitats and species, including elements of the landscape which have the function of structuring and resuscitation should be preserved, provided and protected against negative influences as well as developed and interconnected as much as possible. The project has organized a series of the trainings and advisor support for the national environmental expert who has implemented EIA.

Improvement the work of Land Consolidation Commission (LCC)



According to the Law on Agriculture Land, the Land Consolidation Commission is a legal and formal body responsible for implementing Land Consolidation. The project has organized a series of trainings for pilot municipalities' LCC in the most important phases of LC. In all pilot projects during the implementation phase, LCC were visited and supported by the GIZ team. As mentioned under 6.2, 22 municipalities in the southeastern part of Serbia were visited in the selection phase. Unfortunately, the project could support only 7 local authorities. Due to that fact, the

project also organized trainings for LCC in additional 7 municipalities which were not selected as pilots (Bela Palanka, Vladičin Han, Ražanj, Leskovac, Dimitrovgrad and Kladovo).

Map of clearing area and EIA within LC

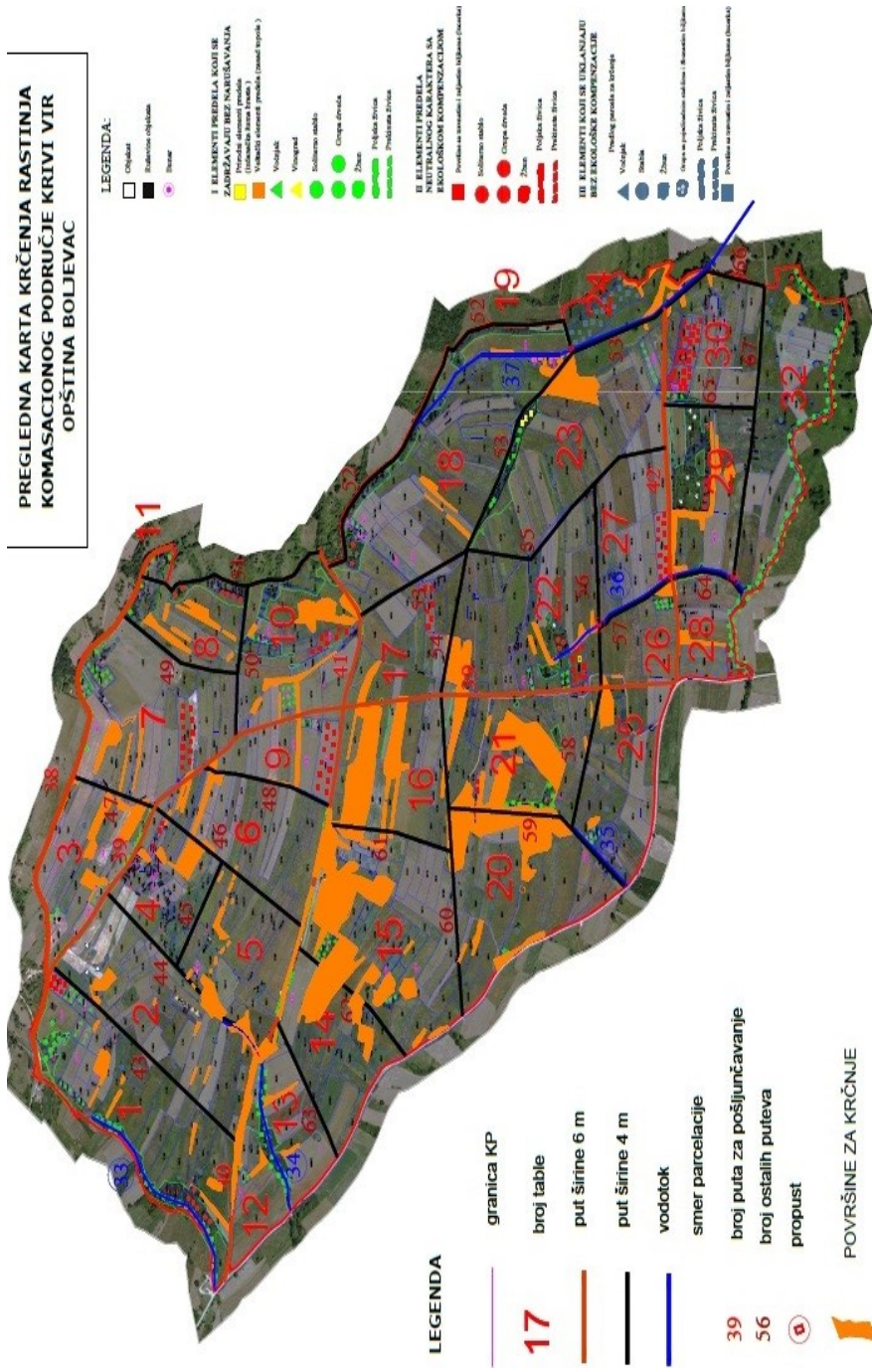

Improvement the role and tasks of Board of Participants (BoP)

The Board's particular role is to mediate between the Land Consolidation Commission and the entirety of the participants; individual private affairs remain a personal issue of the participants. The Board of Participants provides advice for the Land Consolidation Commission and its sub-commissions during the whole course of the project, and it regularly requests information regarding the progress of the project. This perceived role of the Board of Participants shall contribute to better mutual understanding and more transparency in the land consolidation process. This manner of cooperation shall guarantee optimal decisions by the Land Consolidation Commission, and shall make necessary decisions comprehensible. The project has organized the trainings and technical-advisory support for all 7 BoPs.

Main tasks and duties of Board of participants:

a) The Body of Participants and its Board

The entirety of all participating persons in a land consolidation project forms the Body of Participants; to such Body of Participants belong the land owners, other right holders regarding the involved real property as well as all people who are affected by the land consolidation project or who have a true interest in the results of the project to be expected. The circle of the participants is determined through the decision of the Assembly of the Local Self-Government (Municipality) regarding the territory of the land consolidation project (Art. 32 Law on Agricultural Land - LAL). The decision-making body is the „Assembly of Participants“. The Body of Participants is represented by a Board of Body of Participants.

b) Which tasks does have the Board of Participants to fulfill?

The Board of Participants apprehends the common concerns of the participants within the land consolidation project. In particular, the Board has a mediating role between the Land Consolidation Commission and the entirety of the participants; individual private affairs remain a personal issue of the participants. The Board of Participants provides advice the Land Consolidation Commission and its sub-commissions during the whole project course, and requests regularly for information regarding the project progress. The Board disseminates these information under the participants in adequate manner, and conducts information and hints regarding common issues from participant's side, and leads it to the

Land Consolidation Commission. This perceived role of the Board of Participants shall contribute to better mutual understanding and more transparency within the land consolidation process. This manner of cooperation shall guarantee optimal decisions by the Land Consolidation Commission, and shall make necessary decisions comprehensibly.

c) How does consist a Board of Participants of?

The Board of Participants consists of 5 to 7 members, depending of the magnitude of the land consolidation area and the number of participants. Members of the Board don't need to be land owner; at least one member should not be owner of real property. The Board is elected through the Assembly of Participants. The members of the Board elect the Chairman of the Board of the Body of Participants and his (her) Deputy out of their own member circle. How is the Board of Body of Participants elected? The municipality invites the participants to the first meeting of the Assembly of Participants and leads the election of the Board of Participants. After its election, the chairmanship is handed over to the Chairman of the Board; to further meetings, the invitation occurs through the Chairman of the Board.

d) Which issues are not duties of the Board of Participants?

The Board doesn't take influence in the „Decision on the Re allotment Plan “of the Land Consolidation Commission (pursuant to Art. 43 LAL) as well as legal remedies against its decisions. The Board doesn't get any right to informing about single remedies, too.

Meeting with BoP



Improvement of the Land Valuation Methodology



The goal was to improve land valuation methodology through theoretical and practical training (in order to better define differences between land valuation classes). For this purpose, the project supported trainings, technical advisor support and equipment for licensed land evaluation companies (as well representatives of Institute of soil and Institute of vegetables and crops NS, local and national cadaster offices, pilots and farmers) from in order to

enable the implementation of presented methodology improvements.

Statistic data before and after implementation of LC

Pilot municipalities	Number of parcel before LC	Number of parcel after LC	Number of participants before LC	Number of participants after LC	Average size of the parcel before LC (ha)	Average size of the parcel after LC (ha)	The lenght of new field road network (km)	The lenght of new canal network (km)
Boljevac LC area 255 ha	926	409	292	258	0,28	0,63	11,06	1,92
Knjaževac LC area 200 ha	869	352	147	81	0,22	0,55	18,6	1,17
Paraćin LC area 1200 ha	8283	-	1899	-	-	-	-	-
Negotin LC area 2500 ha	12537	5041	1864	1049	0,19	0,80	99	-
Žitorađa LC area 514 ha	2542	1389	926	843	0,20	0,65	46	10,5
Pirot LC area 320 ha	1742	1158	880	955	0,18	0,27	23	-
Svrljig LC area 314 ha	2148	1196	610	411	0,12	0,25	19	5,77

Marking of the new parcels



Handover of the new parcels



Handover of the New Parcels



Conclusion - lessons learned

In general, there is a lack of awareness about the benefits and advantages of LC at all institutional levels. The development of LC programs for planning LC projects required more time than expected. According to the current Law on Agriculture Land, the LC Program is a very important document. Based on the Program, the Municipality may adopt the Decision on Land Consolidation Implementation, appoint the Land Consolidation Commission, adopt the land consolidation principles, secure funding for implementation, initiate public procurement and contracting of works in implementation, as well as monitor the implementation of the works. In accordance to the improvement of legislation, the LC program should also be improved. The experiences gained in implementing LC pilot projects were used as inputs for drafting bylaws and improving LC legislation. Monitoring and improvement of institutional-administration level capacities were necessary during the entire LC process. Clearly defined roles and tasks of all stakeholders, development of standards for technical procedures, ensuring sufficient funding and proper public procurement processes were identified as important preconditions for successful finalization of the projects. Further improvement of legislation is necessary in order that all legal and technical issues could be solved.

Follow up phase Land Management (LM3)

Based on the funding of the Government of the Federal Republic of Germany, in 2016 has started a new project with the aim to further increase the administrative and personnel capacities in Land Management topic, in order to enhance Serbia's agricultural productivity and competitiveness on the EU market.

New parcels with the new graveled field roads



Literature

1. GIZ-SMLM/MAEP (2016): Rulebook on content, procedure for development and adoption of program for land consolidation, content of decision on land consolidation, principles of land consolidation, work of commissions and sub commissions. Bylaw elaborated on behalf of the GIZ project “Strengthening Municipal Land Management (SMLM)” funded by the German Federal Ministry for Economic Cooperation and Development and the European Union. Unpublished draft.
2. GIZ-SMLM/MAEP/RGA (2016): Rulebook on content of technical documentation for geodetic and technical works (projects) in land consolidation. Bylaw elaborated on behalf of the GIZ project “Strengthening Municipal Land Management (SMLM)” funded by the German Federal Ministry for Economic Cooperation and Development and the European Union. Unpublished draft.
3. GIZ-SMLM/Municipalities of Paraćin, Boljevac, Knjaževac, Svrlijig, Negotin, Pirot and Žitorađa (2013): Land Consolidation Programs. Document elaborated on behalf of the GIZ project “Strengthening Municipal Land Management (SMLM)” funded by the German Federal Ministry for Economic Cooperation and Development and the European Union. Unpublished translation. Published original in Serbian Language.

SUPPORT ORGANIC FARMING AS A CLEAN TECHNOLOGY AND DEVELOPMENT OF RURAL AREAS IN THE EU AND SERBIA¹

Svetlana Roljević Nikolić, Predrag Vuković²

Abstract

The aim of this paper is to point out the importance of the role of organic farming, as way of clean production, could have in development of rural areas, through the attraction of financial resources. The paper is structured into two parts. In the first part of the paper, we provide a brief overview of the evolution of the concept of organic farming, followed by an insight into the spreading of these agricultural practices in the world. In addition, an overview of basic data on agriculture in Serbia, and potentials for the development of organic agriculture, and the current state of the sector in our country are also described. Data from FiBL / IFOAM survey (2016) and Eurostat (2015) on organic agriculture served the authors as the basis for this paper. In order for the analysis to communicate trends, findings and conclusions, the authors made use of available data for the period 2005-2014. For the analysis on the Republic of Serbia, available data from the Statistical Office and the Ministry of Agriculture and Environmental Protection were used. The second part of the paper shows a system of support for rural development and organic agriculture in the European Union, as well as in the Republic of Serbia. The sources used in the paper come from official documents of the European Commission and the Republic of Serbia.

Key words: *organic agriculture, rural development, policy support*

¹ Paper work is part of the project research 46006 – “Sustainable agriculture and rural development in function of Republic of Serbia strategic goals achievement within the Danube region”, and project 179028 „Rural work market and rural economics of Serbia - diversification of income and decrease of rural poverty“ financed by the Ministry of Education and Science Republic of Serbia, member of researching team.

² Svetlana Roljević Nikolić, Ph.D., Research Associate, Institute of Agricultural Economics, Belgrade, St. Volgina 15, 11060 Belgrade, phone: +381 11 6972-842, fax: +381 11 6972-848, e-mail: svetlana_r@iep.bg.ac.rs; Predrag Vuković, Research Assistant, Institute of Agricultural Economics, Belgrade, St. Volgina 15, 11060 Belgrade, phone: +381 11 6972-852, fax: +381 11 6972-848, e-mail: predrag_v@iep.bg.ac.rs.

Introduction

Further development of industrialized agriculture is increasingly being questioned because of its negative impact on the environment and the deteriorating quality of food. Therefore, the concept of sustainable agricultural production is based on a balance between economic, ecological and social development has been emphasized in the last decades.

From the social, economic and ecological point of view, organic farming is fully integrated into the concept of sustainable development in the long run. The sustainability of organic production is reflected in the rational use of natural resources, without exhausting, but rather through maintaining and increasing their diversity, leaving no negative impacts on the environment. Organic farming is controlled and subject to inspection, which is why it has the trust of consumers in terms of quality and food safety.

The idea of organic farming is more than 80 years old, but only in the mid 1980ies did it gain in importance, since this production brought dominant economic principles into the best possible correlation with environmental requirements, which is the essence of sustainable development of agriculture (Roljević et al., 2009). Today, organic agriculture is practiced in 172 countries around the world, on around 40.3 million hectares (1% of global agricultural land), on which there are registered 1.8 million farms (FiBL-IFOAM, 2016). The growth in global demand for organic products encourages increase in the total area under organic production. Between 2005 and 2014 the area under organic production increased more than 50%. The total value of organic products at 11 billion euros in 2003 increased to 62.6 billion euros in 2014 (FiBL-IFOAM, 2016).

Compared to developed countries, organic agriculture in Serbia is of recent date, so the size of the soil area under this type of food production is not large. According to data from 2014, there are 7,897 ha under organic production in Serbia, or 0.2% of total agricultural land, which indicates that the current scope of this practice is much smaller than the real potential.

The development of agriculture and that of rural areas are in interaction, which indicates the important role that organic farming can play in improving the quality of life of the rural population. On the other hand, the available economic resources, favourable natural conditions, the existing socio-cultural, and human resources, can contribute to the promotion of organic agriculture in the socio-economic development in terms of sustainability.

The development of the concept of organic agriculture and its basic principles

Rudiments of organic agriculture date back to the early twentieth century. The precursor of the organic movement in agriculture is the "The Agriculture Course" held by the Austrian philosopher Rudolf Steiner (1861-1925) in Poland in 1924. Steiner emphasized the role of farmers in managing and establishing a harmonious life between animals, plants and soil, which share a common living space. He felt that the nature of the industrialization of agriculture increasingly degrades and loses vitality, and that the cause of decline in the quality of food lies in the application of fertilizers and pesticides, and that the transition to a modern, i.e. the chemical-based agriculture in the near future would create a number of problems.

The originator of the idea about the concept of organic agriculture is considered to be a British botanist, Albert Howard (1873-1947), who studied the traditional agricultural practices of Indian farmers, and realized the importance of composting for the maintenance of soil fertility, and thus for the production of crops. The results of his research were published in the book "An Agricultural Testament" (1940) in which he described the key concept of organic agriculture, which is the use of available waste materials from the farm to increase the humus content and improve soil fertility.

During 1909, an American agronomist Franklin Hiram King (1848-1911) studied the traditional systems of fertilization and ploughing in China, Korea and Japan. In his book, "Farmers of Forty Centuries" (1911), King pointed out the emergence of "a worldwide movement for the introduction of new and improved methods of agriculture", and this work has for years served as an important guide for organic agriculture.

The term "organic agriculture" was first used by Lord Northbourne (1896-1982) in his book "Look to the Land" (1940). Northbourne did not use the term *organic agriculture* only in the context of the significance of organic matter to soil fertility, but also as a concept of farm management as an integrated system in which land, crops, animals and man are integrated. This systematic approach is the core of organic agriculture today.

By the end of 1940 organizations like "Soil Association" in Britain and "Bioland" in Germany, which is the first certification organization for organic agriculture in the world, were established.

In Serbia, the development of the NGO sector of organic production began in 1990 with the establishment of associations for organic agriculture Terra's in Subotica. During 2007, the Organic Serbia Fund was established, and in 2009 the National Association for the Development of Organic Production *Serbia Organica*. These three organizations today are leading the development of organic agriculture in Serbia, each with their specific area of operation.

The basic principles of organic agriculture are based on the foundations of sustainable agricultural development, which include the management and conservation of natural resources and direction of technological development to meet the needs of present and future generations. Organic production is based on the sustainable use of natural resources, the preservation and enhancement of biodiversity in agro and self-sufficiency of the farm (Roljević et al., 2009).

State and prospects of development of organic agriculture in the World

The rapid growth of the sector of organic agriculture is a response to the growing needs of consumers who want healthy food, but also a result of the growing concern due to a decline in food quality and environmental protection. In accordance with the established priorities for sustainable development by 2030, goals 2.4 and 3.9 oblige governments to adopt sustainable land management techniques, including those used by organic agriculture in the fight against land degradation (UN General Assembly, 2014).

According to data from the FiBL-IFOAM (2016), organic production is performed on forty-three million hectares worldwide, representing around 1% of global agricultural land (graph 1). Compared to 2005, the area under organic production increased by almost 50%.

Graphic 1. *Organic agricultural land* in the world 2005-2014*

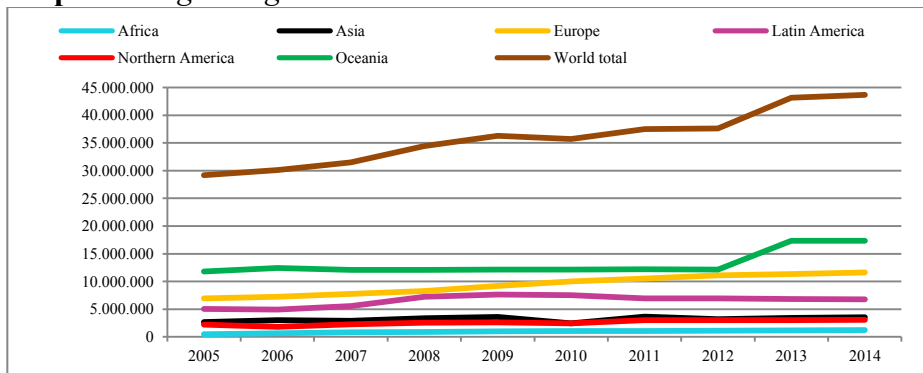

Source: FiBL-IFOAM, 2016, * Certified soil and soil in process of conversion

Countries with the largest areas under organic production are China, Spain, Italy, France and Germany (table 1). These countries have 16.5% of global organic surface area. On the other hand, the countries with the largest share in the total organic agricultural land are Falkland Islands (Malvinas), Liechtenstein, Austria, Sweden and Estonia.

Table 1. *Countries with the largest areas under organic production and the highest proportion of organic land in total agricultural land*

State	ha	State	%
China	1,925,000	Falkland Islands (Malvinas)	36.3%
Spain	1,710,475	Liechtenstein	30.9%
Italy	1,387,913	Austria	19.4%
France	1,118,845	Sweden	16.4%
Germany	1,047,633	Estonia	16.2%

Source: FiBL-IFOAM, 2016.

Based on the data of categories of used land (table 2), it can be seen that the largest share of the used land under organic production is under perennial grasslands (69.7%), followed by agricultural land under agricultural crops (21.5%), while the smallest share is held by perennial crops (8.7%).

Table 2. *Categories of soil use under organic production*

World	Arable land crops	Permanent crops	Permanent grassland
Africa	241,56	601,907	71,003
Asia	1,603,641	541,238	27,699
Europe	5,055,335	1,359,534	4,800,100
Latin America	327,961	797,867	4,546,856
Northern America	37,399	48,695	16,728,022
Oceania	1,245,48	67,525	1,284,296
Total	8,293,971	3,416,766	27,457,976

Source: FiBL-IFOAM, 2016.

On the other hand, the growth of demand for certain products has dictated the growth pace of certain categories of land use. Thus in the period between 2005-2014 the highest average annual growth rate was in the area under perennial crops (10.5%), followed by field crops (8.5%), while the lowest average annual growth rate was that of pastures (3.5%).

The number of registered organic producers is increasing year by year. According to data from the FiBL-IFOAM, the number of registered organic producers in 2014 was around 2.3 million, which is over 200% more, compared to 2005. Similar to the agricultural area, the largest number (almost three

quarters) of organic producers is located in developing countries. In the countries of Asia, Africa and South America, there are registered over 80% of the total number of organic producers, while producers from Europe, Australia and North America account for 17% of organic producers globally.

Organic farming in the European Union

The area under organic production increased significantly in the past ten years. At the level of the European Union, in 2005 the area covered 6.5 million ha, while in 2014, it increased to 10.3 million hectares, which is 60% more than in 2005 (table 3). The largest growth in this period was in Bulgaria, where the area under organic production increased 10 times. A significant increase in the area under organic production in the reported period was recorded in Poland (4 times), Belgium (3 times), Romania (2.7 times) and Estonia (2.6 times).

Areas under organic production vary significantly from country to country. Generally, the larger countries have more surface area under organic production. According to Eurostat data, the largest organic areas are found in Spain (1,710,475 ha), Italy (1,387,869 ha), France (1,118,845 ha) and Germany (1,033,807 ha), which dispose with 50% of the total organic surface of the European Union.

Table 3. *Area under organic production*

Country group	Land area (hectares)	Total land Share (%)	Growth 2005-2014 (%)
EU 28	10,250,742	5.7	59.5
Europe	11,625,001	2.4	67.4
Global	43,662,446	1.0	49.5

Source: *Willer et al., 2015, pp. 40.*

However, looking at the share of organic area in total of the usable agricultural area (UAA) gives a clearer picture of the relative importance of the organic sector in each of the member states, and their ranking is quite different. According to data from Eurostat (date of access to data 07.06.2016.) the share of organic area in total used agricultural area is the largest in Austria (19.3%), followed by Sweden (16.5%) and Estonia (16.3%). The share of organic area in the UAA over 10% is found in the Czech Republic (13.5%), Switzerland (12.7%), Italy (11.5%) and Latvia (10.8%). On the other hand, a very small proportion of the organic UAA are found in Malta (0.31%), Bulgaria (1.03%) and Romania (2.22%). The share of organic area (certified land and land under conversion) in the usable agricultural area at the level of the EU is 5.9%.

Changes in area under organic production should be analysed along with changes in the number of producers in this sector, in order to obtain a clearer picture of the interest in organic agriculture in the country. Eurostat data show that the number of producers on the EU level in 2014 increased by 1.5 times compared to 2005. The number of producers of organic food in 2014 at the level of the EU amounted to 257,525, which is 2.4% of the total number of households (10.8 million³).

Most registered organic producers are located in Italy (45,965), Spain (30,502), Poland (26,598) and France (25,467) and account for 50% of the total number of organic producers in the EU.

Increases in area under organic production have been accompanied by dynamic growth of an organic products market. The total value of the organic market in the European Union in 2005 was 11.1 billion euros, while in 2014 it doubled, and according to Willer et al. (2015) amounted to 24 billion euros. At the same time, the retail value of organic products in the EU is the second largest single market for organic products in the world, after the US (27.1 billion €).

The consumption of organic products per capita in the EU during the period 2005-2014 increased by 110%, or more precisely from €22.4 to €47.4. The consumption of organic food per capita in Europe in general, particularly at the global level, is considerably lower (table 4).

Table 4. *Organic market and production trends in Europe by country group, 2014*

Country group	Retail sales (billion EUR)	Per capita consumption (EUR)	Producers	Land area (million hectares)	Total land Share (%)
EU 28	24.0	47.4	257,525	10.3	5.7
Evropa	26.2	35.5	339,824	11.6	2.4
Global	62.6	8.3	2,260,361	43.7	1.0

Source: Willer et al., 2015, pp. 21.

Dynamic growth is a result of continuous improvement and the introduction of innovations in the system of organic agriculture in order to respond to the high expectations and demands of consumers for quality food, support for the health of the environment, animal welfare and rural development. However, despite the rapid growth of the sector of organic farming, there still exists an imbalance between the volume of production and the growing demand for organic food.

³ <http://appsso.eurostat.ec.europa.eu/nui/show.do>

Agriculture in the Republic of Serbia and its potential for organic food production

The Republic of Serbia has great, so far under-used, ecological, economic and social capacities for agricultural production. The natural characteristics of the soil, the availability of water resources, and climate provide broader framework for structuring of agriculture, that on such grounds, could be viable and sustainable. Due to the numerous factors of degradation in recent decades, there is a tendency of reduction in agricultural land per capita, and globally, each inhabitant has 0.21 hectares of agricultural land at their disposal, while the disposable land per capita in Serbia is almost three times higher, at 0.64 ha of agricultural land per capita. The availability of agricultural land gives Serbia a comparative advantage to develop agriculture in the direction of cleaner production, and production of sufficient quantities of food of very high quality (Filipovic et al., 2013). At the same time, it does not mean that a reasonable or sustainable use of natural resources should not be a priority in any future strategic planning of development of the entire community, both rural and urban.

Table 5. *Land for use by category*

	Total agricultural soil (ha)	Utilised agricultural land (%)	Utilised (%)	Forest (%)	Other land (%)
Republic of Serbia	5,346,597	64.3	7.9	19.1	8.6
Serbia – North	2,302,548	75.8	3.7	7.5	13.0
Belgrade region	253,307	53.8	4.8	10.4	31.0
Vojvodina region	2,049,241	78.5	3.5	7.1	10.8
Serbia – South	3,044,049	55.6	11.2	27.9	5.3
Region Šumadije and Western Serbia	1,865,958	54.4	7.6	33.9	4.2
Region South and East Serbia	1,178,091	57.5	16.8	18.5	7.1

Source: *SORS, 2013 and author's calculations*

The structure of land used by category is given in Table 5. Arable land makes up 64.3% of agricultural land, where 50.7% of this surface area is located in the northern part, which makes a third of the total area of the Republic of Serbia. The remaining 50%, i.e. 49.3% of arable land is located in the Southern part of which represents 72% of the territory of Serbia. The largest share of arable land in total agricultural land is in the region of Vojvodina.

In the structure of the used arable land, farms are dominant with 73.1%, followed by meadows with 20.7%, while perennial crops cover 5.4% of utilized

agricultural area. The most common type of land is chernozem, which is characterised by high productivity. Broken down by bonitet classes, class 1 bonitet is the most widespread in Vojvodina, while in Central Serbia the land belongs to class 6 bonitet, which largely determines the structure of production. In the structure of sown arable land, cereals account for 62.8%, industrial crops for 14.3%, vegetable crops 8.4%, and fodder crops for 14.5% (SORS, 2014).

The largest part of agricultural land, about 87% is privately owned and this ownership structure has a negative impact on the size of the average farm. In Serbia most farms are small and medium-sized, up to 2 hectares (47.2%) and 5 hectares (28.9%), which puts Serbia among the countries with a high degree of fragmentation of holdings, i.e. the smallest agricultural holdings in Europe (graph 4). Small land properties together with the extensive character of production and the low level of utilization of existing processing capacities significantly reduces the productivity of the domestic agribusiness sector, which has a negative effect on the income of households. Only 6,245 agricultural households have a surface area greater than 50 hectares, but they have roughly one-third of total used agricultural land at their disposal. Households with small holdings are located primarily in central and southern Serbia, and they produce various crops, including fruit, vine and vegetable crops, while in the territory of Vojvodina there are larger farms specialized for vegetable crop production.

Graphic 4. *Agricultural holdings (AH) in Serbia by the usable agricultural area, according to the Agricultural Census 2012, in %*

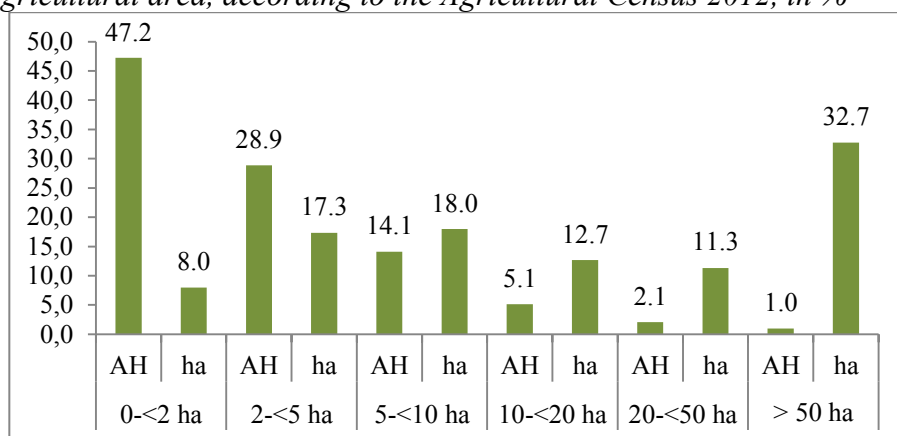

Source: SORS, 2013 and author's calculations

Agriculture is an important economic sector in Serbia, and it is the basis of economic development and the driving force behind the development of rural areas. According to the data from the Ministry of Agriculture from 2014, the

share of agriculture in total employment was over 21%, the share of GVA of agriculture in GDP was at 8.1%, while the share of agri-food products in indicators of foreign trade exports was 20.8%, and 8% in imports (MAEP, 2014, Book 1).

Although it has been present in our areas for twenty years, organic agriculture has not reached its real potential, since only 7,897 ha of 3,294,922 ha of arable land is under organic crops. The structure of crop production is dominated by vegetable farm crops (67%), followed by fruit production (28%), while vegetable gardening is practiced on only 2% of cultivated land in the organic production system (Table 6).

Table 6. *Areas under organic production in Serbia in 2014.*

Category	In the period of conversion (ha)	Certified areas (ha)	Total (ha)
Cereals	1,842	985	2,877
Industrial plants	1,095	133	1,228
Fodder crops	350	854	1,204
Vegetable	22	131	153
Fruit	731	1,477	2,208
Medicinal and Aromatic Plants	6	55	61
Rest	201	13	214
Total arable land	4,249	3,648	7,897
Meadows and pastures	527	1,022	1,549
Total	4,726	4,670	9,446

Source: MAEP, 2014, Book 2.

The structure of growing is dominated by growing arable crops, mainly cereals, which cover 36.4% of organic arable land. The most common is the cultivation of wheat, barley, rye, triticale, corn, soybean and sunflower. Around 28% of organic arable land is under orchards, and the most common practice is to grow apples, plums, raspberries, cherries and strawberries.

The number of farms that practice organic production is 1,876, which is 0.3% of the total number of farms in Serbia. The largest number of farms are in the south, followed by west Serbia and Vojvodina, and the area intended to organic production does not exceed 15-25% of the total holdings.

According to MAEP (2014) in 2013, the total quantity of exports amounted to 7,101 tons, which is 4.5 times more than in 2012 (1,562 tons), while the total value of exports in 2013 (101 million euros) was higher by 27 times compared to 2012 (3.74 million).

Policy support for rural development and organic agriculture in the EU

Rural areas represent more than 77% of the total area of the EU (47% agricultural land and 30% forests) and they are inhabited by about half the population of the European Union (DG AGRI, 2015), which is why the rural development policy is one of the most important ones for the economic growth of the EU, both because of the number of regulations, and in terms of participation of the policy of development of agriculture in the total budget of the European Union. The roots of rural development policy can be found in the Common EU agricultural policy (CAP).

The Common Agricultural Policy (CAP) is one of the most important areas of functioning of the EU institutions. It aims to support agriculture that guarantees food safety (in the context of climate change) and to ensure sustainable and balanced development of rural areas, including areas with difficult production conditions. Overall, the CAP is based on two pillars:

(1) *Direct subsidies to farmers and support for the market of agricultural products* include direct financial assistance to farmers in order to provide a stable income. To be eligible for subsidies, farmers must now respect the principle of cross-compliance, which is based on two sets of rules. The first relates to the regulations in the production concerning the protection of the environment, human health, plant and animal welfare, while the second group relates to good agricultural practice with the aim of preserving the land in good condition.

(2) *Rural development*. Rural development policy is implemented through three elements: 1) improving the competitiveness of the agriculture and forestry 2) improving environmental protection and rural areas, and 3) improving life in rural areas and diversification of the rural economy. All rural development programs must include measures for the protection and improvement of natural resources and the environment in rural areas. Organic farming has to comply with all measures of protection and improvement of natural resources and the environment in rural areas, i.e. it can contribute to their realization. On the other hand, all these measures create favourable conditions for the spreading of organic farming.

The Common Agricultural Policy (CAP), with new strategic framework for 2014-2020, has experienced a significant reform. The reform of the CAP is aimed at a more equitable distribution of budget funds between Member States, the most significant changes in the policy relating to the introduction of so-called. "Green payments", which will in the long term make possible sustainable

food production, sustainable management of natural resources in terms of climate change and balanced territorial development. In short, the agriculture of the European Union should achieve a higher level of safe and quality food, while preserving the natural resources on which it directly depends.

The *European Agricultural Guarantee Fund* (EAGF) finances direct payments to farmers and measures to regulate agricultural markets such as intervention and export refunds, while the *European Agricultural Fund for Rural Development* (EAFRD) finances the rural development programmes of the Member States. The total budget of the CAP for the period 2014-2020 amounts to 408 billion euros, of which 313 billion euros is meant for the financing of measures under the first pillar policy, while 95 billion euros is earmarked for the financing of rural development policies (table 7). The budget of the CAP makes 37.8% of the total budget of the Union, indicating a significant reduction in the share of the total EU budget in the past 30 years, when the share of the CAP accounted for up to 75% of the total budget.

Table 7. CAP budget for period 2014-2020 (in billion EUR)

	2014-2020 Ceiling (Current Prices)	2014-2020 Ceiling (2011 Prices)
Pillar 1	312.74	277.85
Pillar 2	95.58	84.94
Total CAP	408.31	362.79

Source: *Overview of CAP Reform 2014-2020, European Commission, No. 5, 2013*

Agri-environmental programs of the CAP encourage and stimulate farmers to be more environmentally conscious, and use financial assistance to direct farmers to adapt their conventional agricultural practice to methods of sustainable use and management of natural resources. Since 2015, all EU Member States will have to focus 30% of the funds meant for direct payments to farmers on financing sustainable agricultural practices, and on making the Common Agricultural Policy “greener” (“Multiannual Financial Framework 2014-2020 and the financing of the CAP”).

Furthermore, at least 30% of the budget for the program of rural development should focus on the support of agri-environmental measures, organic farming or investments in projects that are in harmony with the environment. The expected budget support for agri-environmental measures in the context of rural development amounts to about 25 billion euros.

Support for organic agriculture in the European Union and neighbouring countries includes grants under the program for rural development, legal protection, as well as European and national action plans. The total amount of resources devoted to organic agriculture from the European Fund for Development of Agriculture and Rural Development (EAFRD) for the period 2014-2020 amounts to 6,286 Billion Euros, or 6.4% of total EAFRD funds (€ 95.58).

Policy support for rural development and organic agriculture in Serbia

According to OECD definition, 85% of Serbia's territory belongs to rural areas, with almost 55% of the total population (Bogdanov, 2007). Besides human resources in rural areas are the most concentrated natural resources, economic activities and cultural heritage. Rural development policy in Serbia is under the Ministry of Agriculture and Environmental Protection and the Law on Agriculture and Rural Development ("Off. Gazette of RS", no. 41/2009 and 10/2013, Article 3) implementation of the policy is carried out through implementation of the Strategy for agriculture and rural development in the Republic of Serbia, the National Programme for agriculture, and the National Programme for Rural development. The implementation of agricultural policy is carried out through direct, market and structural incentives. Structural incentives include the rural development measures which relate to:

(1) Improving the competitiveness of agriculture and forestry. These incentives are implemented through investments in agricultural production and investment in agricultural product processing and marketing.

(2) The improvement of environmental programs, biodiversity conservation and diversification of the rural economy is realized through incentives for organic production and incentives for the conservation of plant and animal genetic resources. The incentives for organic production in 2014 were increased 40% compared to premiums, incentives for production and recoveries in conventional production (MAEP, 2014, Book 1).

(3) Improving the quality of life in rural areas is being implemented through incentives for economic activity in terms of adding value to agricultural products, as well as the introduction and certification of food safety and quality, organic products and products with geographical indications.

A total of 262 million euros is intended for the realization of the policy of incentives in agriculture and rural development in 2013 by Regulation (table 8), whereby according to the Ministry of Agriculture and Environment, 234.8 million

euro has been realized (MAEP, 2014, book 1). The most common form of subsidies are direct payments, to which 92% of total assets are devoted. The second most common form of incentives is support for rural development, for which about 10.5 million euros have been allocated in 2013, i.e. 4% of total intended funds. As part of the funds intended for incentives for rural development, 1.7 million, or 16.6% is defined for the development of organic agriculture.

On the other hand, the policy of implementing incentives in agriculture and rural development in 2016 has received 159 million euros in accordance with the Regulation (table 8), which is 40% less compared to 2013. Direct payments are still the most common, with a share of 86%, but the share of rural development support increased to 9% in the total amount of funds. What is worrying is the fact that the funds intended for stimulating organic agriculture drastically reduced and in 2016, and amounted to only 747,000 euros, which is 5% of the funds intended for incentives for rural development.

Table 8. *The amount of subsidies in agriculture and rural development in 2013 and 2016, converted into EUR*

	2013*	2016**	Index 2016/2013
Direct payments	242,305,846.40	137,844,597.90	-43.11
Rural development	10,494,954.45	14,941,510.97	42.37
Organic farming	1,745,200.70	747,359.87	-57.18
Credit support	4,363,001.75	4,874,086.11	11.71
Special support	4,851,657.94	1,889,926.89	-61.05
Total	262,015,460.60	159,550,121.90	-39.11

Source: *Regulation on the allocation of subsidies to agriculture and rural development in 2013. and 2016.*

* Average exchange rate of the euro as of 31.12.2013 amounted to 114.6421 RSD.

** Average exchange rate of the euro on the day of 31.05.2016 amounted to 123.1015 RSD.

Development of Organic Agriculture in Serbia takes place relatively slowly, but it is possible to accelerate the development through appropriate incentives. According to MAEP (2014) investment in organic production could contribute to an increase in the area under organic production by 25% compared to the current situation.

Bearing in mind that the current structure of the budget for the pillars of support for agriculture and rural development is uneven, with a distinct domination of the first pillar, the Strategy of Agriculture and Rural Development of the Republic of Serbia 2014-2024 plans for a more equal distribution (table 9). Such

a policy and a strong focus on the measures of the second pillar of support, put together a much stronger emphasis on development, in order to achieve greater compatibility with the EU model.

Table 9. *Projected agricultural budget RS, 2014-2024, mln. euros*

	2013	Sub-period of economic crisis (2014-2016)	Sub period re-growth and access to IPARD funds (2017-2020)	New sub period programming period EU (after 2020)	Approach
I pillar	230	240	370	530	680
II pillar	20	30	85	150	750
Special subsidies and more	30	35	50	75	110
Total	280	305	505	755	1,540

Source: *Agriculture and Rural Development of the Republic of Serbia 2014-2024, p.84, (Official Gazette RS, 85/2014)*

By starting the negotiation process for accession to the EU in the field of agriculture and rural development, there appears an imperative need to harmonize national policies for agriculture and rural development with the rules and principles of the Common Agricultural Policy. In order to help candidate countries to adapt the agricultural sector and rural areas to the premises of the Common Agricultural Policy, the EU provides support in the form of IPARD funds (Instrument for Pre-Accession Assistance in Rural Development).

Out of the total budget of IPARD II for the period of 2014-2020, intended for Serbia, around 44% was planned for the measure “Investment in physical property of agricultural households”, and around 35% for the measure “Investment in physical property concerning processing and marketing agricultural products and fishery products”. The measure “Diversification of agricultural households and business development” are planned to receive 10% of the total budget with the goal of stabilising income in rural areas. The planned investments for improving agri-eco-climate measures are 5% of the total budget. The agri-ecological measure most often given support to is organic agriculture, both due to the overall gain it has for the environment and biodiversity protection, and for the increasing economic potentials of organic food.

Conclusion

The sector of organic agriculture is growing rapidly, but it still only represents a small part of the global agriculture. The data indicate that organic agriculture is

most widespread in developing countries, in marginalised areas where the conditions for implementing conventional/industrial agriculture are limited.

The European Union is one of the world leaders in the sector of organic agriculture, both in the aspect of areas under organic production, scope of production and the market for organic products, as well as the aspect of developing systems of institutional support for this sector.

The development of organic agriculture in the Republic of Serbia has until recently been quite slow, but it certainly possesses great natural potential for increase with adequate support and incentives. However, the assets for organic agriculture are increasingly modest. Bearing in mind that the existing budget structure meant for incentives in agriculture is uneven, with a distinct dominance of direct payments, the Strategy for Agriculture and Rural Development of the Republic of Serbia 2014-2024 predicts a more equal distribution. Besides, in the following period, Serbia will see assets from the IPARD fund for incentives in agri-eco-climate measures, and primarily organic agriculture, which is a prerequisite for its continued growth.

Based on the growth of need for organic food and the growth of the market on the global, and mostly the market of the EU, the organic sector in Serbia has the potential to become a leader in sustainable and holistic land development. Bearing in mind the disparity between organic food production and demand, Serbia has the opportunity to use the potential of investments in organic production. In that sense, the sector of organic agriculture can play an important role in support for rural areas through attracting investments.

Literature

1. Bogdanov N. (2007): *Small rural households in Serbia and the rural non-farm economy*, UNDP, Belgrade
2. DG AGRI, http://europa.eu/rapid/press-release_MEMO-13-631_en.htm
(10.06.2016)
3. European Commission (2013): *Overview of CAP Reform 2014-2020*, http://ec.europa.eu/agriculture/policy-perspectives/policy-briefs/05_en.pdf
(10.06.2016)
4. EUROSTAT, http://ec.europa.eu/eurostat/statistics-explained/index.php/Organic_farming_statistics

5. Filipović Vladimir, Roljević Svetlana, Bekić Bojana (2013): *Organic production in Serbia – the transition to green economy*, Chapter 9 in „Sustainable Technologies, Policies, and Constraints in the Green Economy“, Advances in Environmental Engineering and Green Technologies Series, Information Sciences Reference (an imprint of IGI Global) USA, pp. 172-188; DOI 10.4018/978-1-4666-4098-6.ch009
6. IFOAM, http://www.ifoam.bio/sites/default/files/poa_english_web.pdf
7. King F. H. (1911): *Farmers of Forty Centuries*, edited by Steve Solomon and Charles Aldarondo, 2012, Blackmask Online <http://encyclopaedia.com/ebooks/37/46.pdf>
8. Law on Agriculture and Rural Development "Official gazete RS", No. 41/2009 and 10/2013
9. *Multiannual Financial Framework 2014-2020 and the financing of the CAP*, http://ec.europa.eu/agriculture/cap-funding/budget/mff-2014-2020/mff-figures-and-cap_en.pdf (10.06.2016)
10. Regulation on the allocation of subsidies to agriculture and rural development in 2013 Official gazete RS", No. 20/13
11. Regulation on the allocation of subsidies to agriculture and rural development in 2016. Official gazete RS" No. 8/16.
12. Research Institute of Organic Agriculture (FiBL) and IFOAM - Organics International (2016): *The World of Organic Agriculture, Statistics and Emerging Trends 2016*, <https://shop.fibl.org/fileadmin/documents/shop/1698-organic-world-2016.pdf> (18.06.2016)
13. Roljević Svetlana, Hamović Vladana, Sarić Radojica (2009): *Organic agriculture in terms of sustainable development*, journal "Economics", Faculty of Economics in Nis, No. 3/2009, p. 99-109, ISSN 0353-8648, UDK 502.131.1:338.43, UDC 33
14. Statistical Office of the Republic of Serbia (2013): *Census of Agriculture 2012 Agriculture in the Republic of Serbia* <http://pod2.stat.gov.rs/ObjavljenePublikacije/Popis2012/PP-knjiga1.pdf>

15. Statistical Office of the Republic of Serbia (2014): Statistical Yearbook of the Republic of Serbia 2014
16. Strategy for Agriculture and Rural Development of the Republic of Serbia 2014-2024, p.84, (Official Gazette RS, 85/2014.)
17. The Ministry of Agriculture and Environmental Protection (2014): *Report on the state of agriculture in the Republic of Serbia in 2014*, Book 1 and Book 2, <http://www.mpzss.gov.rs/korisna-dokumenta-i-linkovi/> (28.06.2016)
18. The Ministry of Agriculture and Environmental Protection (2014): *The Republic of Serbia IPARD program for 2014-2020* <http://ipard.co.rs/doc/srbija-ipard-2-program.pdf> (10.06.2016)
19. United Nations, General Assembly (2014): The road to dignity by 2030: ending poverty, transforming all lives and protecting the planet, Synthesis report of the Secretary-General on the post-2015 sustainable development agenda
20. Willer Helga, Schaack Diana, Lernoud Julia, Meredith Stephen (2015): *Growth trends in European organic food and farming*, pp. 20-58, in publication: Stephen Meredith and Helga Willer eds (2015): *Organic in Europe prospects and developments 2016*, IFOAM EU Group, FiBL

RENEWABLE ENERGY AND ENERGY EFFICIENCY IN AGRICULTURE AND RURAL AREAS IN SERBIA¹

Vesna Paraušić²

Abstract

The author analyses strategic and legal regulatory rules of Serbia in the field of renewable energy (RE) and energy efficiency, state in the field of RES and energy efficiency in agriculture and rural areas, and possibility to apply the small and mobile renewable energy generators in different aspects of agricultural production and rural development in Serbia. The goal of this manuscript is to point out to possibilities that the users of energy production devices from renewable sources (primarily agricultural manufacturers, rural population, etc.) can achieve economic interest by using these devices; produce more healthy and quality product (especially in organic production); provide energy in those areas without the built electric grid; increase energy efficiency and achieve a positive effect to the environment in a longer period of time.

Key words: *renewable energy, energy efficiency, agriculture, rural areas.*

Introduction

The Republic of Serbia has been on its way to sustainable development since the year 2002 by implementing the Johannesburg Declaration on Sustainable Development (UN, 2002) in its strategic documents and always taking into consideration the Rio Declaration on Environment and Development (UNEP, 1992), the Agenda 21 (UNEP, 1992a) and three Rio conventions (UNDP/UNEP, 2012).

¹ This paper is a part of research projects No. 46006 financed by the Ministry of Education, Science and Technological Development of the Republic of Serbia (2011-2017).

² Vesna Paraušić, Ph.D., Research Associate, Institute of Agricultural Economics, Volgina Street No. 15, 11060 Belgrade, Serbia, phone: +381 11 6972 847, e-mail: vesna_pa@icp.bg.ac.rs.

In the national report of the Republic of Serbia for the World Conference on Sustainable Development “Rio+20” (UNDP/UNEP, 2012), there underlines the commitment of Serbia to sustainable development and the green economy principles, more efficient use of resources, along with the process of social inclusion and employment decrease.

In terms of climatic changes and limited land and water resources, the development of agriculture and rural areas on the sustainability principles, green economy and RE use, which requires the minimum engagement of limited land and water resources, and doesn't violate their ecological status, becomes an important issue for the future of the world food production. One of the ways to reduce the use of fossil fuels is their partial substitution by energy from renewable sources, which is very up-to-date in the field of agriculture and rural development.

The concept of RE and “green economy” in sectors such as agriculture, fishery and forestry is integrated in the Common Agricultural Policy of EU (CAP), in which the support to “green economy” implies the targeted assistance to rural development measures, which promote the ecologically sustainable agricultural practice, such as agro-ecological schemes and the improvement of compliance with the environmental protection laws. The reformed Common Agricultural Policy for the program period 2014-2020 for 28 EU member countries put emphasis on: „improvement of agricultural competitiveness by the promotion of innovations; environmental protection; sustainable management of natural resources; climate changes“. Achievement of the rural development objectives is realized through six priorities of the Union, while the support in using renewable sources is available through the fourth and fifth priority of EU for rural development (Regulation of EU, No. 1305/2013):

- ✓ “Renewal, preservation and improvement of eco-system connected to agriculture and forestry” and
- ✓ “Promotion of efficiency in using resources and encouraging moves towards the economy with low level of carbon, resistant to climate changes in the agricultural, food and forestry sector”.

National regulations in the field of renewable energy (RE) and energy efficiency

The most important national regulations in the field of RE and energy efficiency are the Law on Energetics (Official Gazette of RS, No.

145/2014) and the Law on Efficient Use of Energy (Official Gazette of RS, No. 25/2013).

Among other things, the *Law on Energetics* (Official Gazette of RS, No. 145/2014) accentuate that long-term objective of Serbia in the field of energy policy and specify the economic and financial conditions for energy production from renewable sources, which are defined as the non-fossil energy sources (watercourses, biomass, wind, sun, biogas, landfill gas, gas from the sewage treatment power plants and geothermal energy sources). The third energy package of EU in Serbia has been applied since 1st January 2015 in the field of RE, electric power and gas sectors. In this way, Serbia has become the first country in the region which had applied all these regulations.

The environment for investing into the energy sector was improved by adopting the Law on Energetics. In order to reach a binding share of energy from renewable sources in gross final consumption of energy, in accordance with the ratified international agreements, all privileged producers of electricity from RE are entitled to direct incentive measures (“feed in” tariff) by the conclusion of a contract on electricity purchase with a guaranteed (public) supplier.

The status of the privileged electricity producer from RE is precondition for signing a contract with the public supplier on electricity sale by the incentive prices, where a RE power plant owner is not obliged to gain this status (in that case, he cannot count on the incentive measures). In order to have a right to the incentive measures, the privileged producer is obliged to sell all produced electricity exclusively to the guaranteed supplier. Status of electricity producers from the renewable resources has not been still regulated by the law, in regard that the adequate bylaws have not been adopted. Among other things, it is necessary to establish officially the system of origin guarantee, while the adoption of Regulation on origin Guarantee was planned for the fourth quarter 2016 (KEI, 2016).

The production of electrical and thermal energy for *own needs* by using RE is considered as a measure of the efficient energy use in sense of the *Law on Efficient Energy Use* (Official Gazette of RS, no. 25/2013). Support to producers which produce the renewable energy for their own needs doesn't currently exist, although it is anticipated by the Law on Efficient Energy Use.

In accordance with this law and the Decision to open the Budget fund for the improvement of energy efficiency of the Republic of Serbia (Official Gazette of RS, No. 92/13), in 2014 has started to operate the Budget Fund for the Improvement of Energy Efficiency, which should stimulate, through financing or co-financing the appropriate projects, programs and activities, also the use of RE for the production of electrical and thermal energy for their own needs, as well as other activities which aim to more efficient energy use.

During the years 2014 and 2016, through public calls, the funds were allocated only for the energy efficiency improvement projects in the local authority units.

Domestic regulations in the field of RE are adjusted to the Directive 2009/28/ EC of the European Parliament and Council on the promotion of renewable energy use and amendment and repeal of directives 2001/77/EC and 2003/30/EC. The directive was partly carried over into the national legislature by adopting the Law on Energetics and appropriate regulations (KEI, 2016).

It is important to adjust with the Directive 2006/32/EC of European Parliament and Council in the field of energy efficiency since 5th April 2016 on final consumption efficiency and energy services (Directive 2006/32/EC were replaced with the Directive 2012/27/EU on energy efficiency). The Directive 2006/32/EC is still relevant for Serbia (until the end of 2017) in regard to its obligation towards the Energy Community and it was substantially transposed into the applicable Law on Efficient Energy Use, while the complete adjustment will be realised by adopting all by-laws. The Law on Efficient Energy Use was partly adjusted to the Directive 2012/27/EU on energy efficiency (KEI, 2016).

Analysis of state in the field of RE and energy efficiency in Serbia

According to data of the Statistical Office of the Republic of Serbia (SORS), an extremely low share of renewable sources in **energy production** in the Republic of Serbia is noticeable (Table 1). According to the same resource, the dominant share within the renewable energy production in the year 2014 had wood fuels and hydro-electric energy (Table 2).

Table 1. Primary production of energy in Serbia, 2014

	TJ (terajoule)	%
– Coal	239.185	60
– Hydro-electricity	41.821	10
– Solar electric power	22	0
– Crude oil and natural gas liquid	50.592	13
– Firewood ^{/1}	46.532	12
– Natural gas	20.639	5
– Geothermal energy	235	0
– Biogas	215	0
TOTAL	399.241	100

^{/1} Final consumption of firewood for households was taken over from the Ministry of Mining and Energy.

Source: *Statistical Yearbook of the Republic of Serbia, 2016, SORS.*

Table 2. Renewable energy production in Serbia, 2014

	TJ (terajoule)	%
– Hydroelectricity	39.611	44
– Solar electricity	22	0
– Wood fuels ^{/1}	50.048	56
– Geothermal energy	235	0
– Biogas	215	0
TOTAL	90.131	100

^{/1} Final consumption of firewood for households was taken over from the Ministry of Mining and Energy.

Source: *Statistical Yearbook of the Republic of Serbia, 2016, SORS.*

On the other hand, in the Study on the Achievements and Perspectives towards the green economy and sustainable growth in Serbia (UNDP/UNEP, 2012) was stated that the energy potential of renewable sources in Serbia was very significant. Technically usable potential of RE, without large hydro-power plants, amounts over 4.3 million tons of equivalent oil per year (Ibid).

In accordance with the Republic of Serbia Strategy of Energetics Development data until 2025, with projections until 2030 (Official Gazette of RS, No. 101/2015), the total technically available potential of RE in Serbia evaluates on 5.65 million of toe per year. Of this potential, there already uses 1.054 million toe of biomass (mostly as firewood) and 909 thousands toe of hydro energy.

According to the Decision on establishing the Energy Balance of RS for the year 2016 (Official Gazette of RS, no. 113/2015) in the structure of

planned total domestic production of primary energy for 2016, the renewable energy participates with 17%. There is planned the increase of primary energy production from wind, sun and biogas, but also the reduction of primary energy from hydro-power plants (Ibid).

Since the year 2009, when the legal framework with incentives (“feed-in” tariffs) was established for the first time in Serbia, many new facilities for electricity production from the renewable sources were built, while solar energy records the most dynamic developmental trend regarding a number of projects. Ministry of Mining and Energy of the Republic of Serbia keeps the Register of Privileged Electricity Producers³.

The installed power of power plants to renewable sources (November 2016) was given in Table 3, as well as the objective to produce energy from renewable sources for 2020.

Table 3. *Installed power of plants to renewable sources 2016 and the goal by the end of 2020*

Technologies	Installed power (MW) November 2016	National goal (MW) 2020
Mini hydroelectric power plants	40.9	188
Wind	0.5	500
Sun	8.7	10
Biomass	0	100
Biogas	5/5	30
Geothermal energy	0	1
Waste	0	3
Landfill gas	0	10

Source: <http://zelenirazvoj.org/aktivnosti/mapa-projekata-obnovljivih-izvora-energije/>, accessed on November 15, 2016.

Since Serbia is a member of the Energy Community, aiming to integrate its energy sector into the EU energy system, there was predicted by the national strategic documents more efficient energy use and increasing the share of RE in gross *final consumption of energy*. In accordance with the Directive 2009/28/EC on the promotion of the renewable energy use and the decision of the Energy Community Ministerial Council (D/2012/04/MC – EnC),

³ Ministry of Mining and Energy of the Republic of Serbia, Sector for Energy Efficiency and RE, RE Department, Register of privileged electricity producers, 23rd November 2016, available at: <http://www.mre.gov.rs/doc/registar23.11.16.html> (date of access 27th November 2016)

National Action Plan for Using RE of the Republic of Serbia was determined a very ambitious binding objective for Serbia in the field of RE, which was amounted 27% of RE share in its gross final consumption of energy in 2020, where increasing energy efficiency (Official Gazette of RS, No. 53/13) is of the utmost relevance.

According to data from the Report on Practicing of the National Plan for Using Renewable Energy of the Republic of Serbia (Official Gazette of RS, No. 8/2015), the share of RE in gross final consumption of energy in 2013 was amounted 19.1% (in the production of electricity 37.8%), which still hasn't achieved a basic share of 21.2% in 2009⁴. The reason for this is not the reduction of RE consumption in Serbia, which surely records real growth, but the fact that due to the other macro-energy disturbances, the gross final energy consumption in Serbia drastically changes, which directly reflects on a proportionally expressed amount of RE share in the gross final consumption of energy. The significant impact to energy consumption has the Ironworks Smederevo, l.l.c., i.e. import and consumption of coke and electricity which use in this company, so when this Ironworks works, the consumption of gross final energy in Serbia increases for several percentages, which furthermore reflects on the RE percentage reduction (Ibid).

As to data on energy efficiency and RE production and consumption for own consumption, there are no systematized and relevant data. Some of the reasons are:

- Small production of electrical and thermal energy from renewable sources, for which no energy permit for facility construction is required;
- No license for conducting the energy activities is required. It issues only for conducting wholesale electricity supply activities (production of electricity in the facilities of total approved power of 1 MW and more) and under conditions determined by the Law on Energetics;
- Energy produced in this way is not delivered in the electro-energy system,
- Neither incentives, nor the register of incentive users.

⁴ Most of the current RE use refers to the traditional way of biomass use and large hydro-power plants.

State and possibilities for energy efficiency and using RE in agriculture and rural areas in Serbia

According to data of the Statistical Office of Republic of Serbia (total energy balance, 2015), within the final energy consumption in the year 2015, agriculture had participated with 1.9%, while oil and petroleum products had been consumed the most within.

Renewable energy in domestic agriculture is insufficiently researched and utilised and there is also no systematized and relevant data on the current production and consumption of renewable energy for own consumption on agricultural holdings.

Some data are given by Statistical Office of Republic of Serbia (Census of Agriculture in 2012 in the Republic of Serbia), like following:

- ✓ Utilized agricultural area (UAA) under crops for energy production (crops meant for the production of biofuels: grain, legumes, soy, oilseed rape, potato, fodder, meadows and pastures hay, etc.) amounts 3,087 ha (or 0.09% of UAA);
- ✓ Only 22 agricultural holdings (of totally 631,552) are engaged in the production and sale of energy from renewable sources, as the second profitable, non-agricultural activity⁵.

Opportunities of the RE use in agricultural production in the Republic of Serbia are determined by following factors (Ministry of Agriculture and Environment of the Republic of Serbia, 2016):

- ✓ Geographic location of land,
- ✓ Climatic, soil and hydrological characteristics (natural resources),
- ✓ Technical-technological developmental level of society,
- ✓ Educational level and ecological awareness of people,
- ✓ Financial possibilities of a state,
- ✓ Economic possibilities of agricultural holdings,
- ✓ Administrative-legal regulations in the field of natural resources use,
- ✓ Long-term world and European strategies of rural development and fight against the negative effects of climate changes.

⁵ In accordance to Census of Agriculture methodology (2012), the production of renewable energy implies the production and sale of energy obtained by using wind energy, burning of straw, producing biogas etc. , and if a holding uses the energy obtained in such way exclusively for own needs, this activity doesn't register.

Solar energy, wind energy and hydro-energy of watercourses are at this moment the most appropriate and the most effective forms of RE for the application in agrarian practice taking into account (Ministry of Agriculture and Environment of the Republic of Serbia, 2016; Despotović et al, 2016):

- Wealth of natural resources,
- Requirements of modern agricultural production⁶ and
- Characteristics of agricultural production, which are given below.

The most important characteristics of domestic agriculture are following (Census of Agriculture in 2012 in the Republic of Serbia):

- ✓ Dominant share in the total number of agricultural holdings have family agricultural holdings, which make 99.5% of total number of agricultural holdings and dispose with 82.2% of UAA.
- ✓ Small plots. The average size of UAA per holding amounts 5.4 ha, and 77.4% of agricultural holdings have UAA ≤5 ha. Also, the average number of separate lots of UAA per holding is six, and the average separate lot covers 0.98 ha. Observing by regions, the average size of separate lots of UAA per holding is the least in the region of Šumadija and Zapadna Srbija (0.77 ha) and in the region of Južne i Istočne Srbije (0.51 ha).
- ✓ Agricultural holdings irrigate only 2.9% of UAA.
- ✓ According to a type of agricultural production, there dominate mixed holdings for plant and livestock production (share of 31.4%).
- ✓ Prevalently extensive and relatively expensive production (significant percentage of farmers work in traditional way, without any agro-technical measures).

Keeping in mind the above, author consider that ***solar and wind energy and hydro-energy of watercourses*** in agricultural production and in rural areas in Serbia can be efficiently used by the development, supply and promotion of ***small*** and ***mobile*** (portable, movable) ***power generators of less power*** (installed power less than 10 kW).

Some of these power generators are (Ministry of Agriculture and Environment of the Republic of Serbia, 2016; Despotović et al, 2016):

⁶ High level of business flexibility; mobility and transport, i.e. change of location; economic, social and ecological sustainability of business, food safety; rational use of land, water and energy within the energy efficiency, etc.

- ✓ **Mobile solar electronic generator.** This is a device which is reliable, tested and verified in the field by the Institute Mihajlo Pupin, Belgrade and Institute of Agricultural Economics, Belgrade. It provides, besides other things, the use of single-phase vacuum pumps for irrigation (power up to 2.5 KW), as well as more powerful three-phase pumps (up to 4KW). The device recharges by energy onsite, based on solar panels in the device or by night from the power grid at a reduced rate. It belongs to the group of extremely economic and noiseless devices, which satisfy high economic and ecological criteria for application in agriculture. This technical solution has great potential in the application of environmental and clean energy technologies in crop and livestock production. One of the most effective applications is in crops irrigation (on fields, orchards, etc.). One of more significant optimisations in Mobile Solar Generator is dual axis drive and tracking of sun trajectory.
- ✓ **Small wind turbines.** Although Serbia doesn't belong to those countries which have many windy days, this natural resource can be very significant as an additional energy source. In the morning or at sunset, due to the local difference in temperature (between plough land/garden and forest, plough land/garden and river, in gorges around the canals and river), there occurs the adequate airflow which affects the microclimate conditions in the specific location. These favourable conditions for using airflow can be used for starting the wind-generators of less power, mobile or stationary, which can serve, for example, for pumping water out of the pool (Renney well, canal, pond, river, lake). This device also works in low wind flow, but cumulatively, within 24 hours, it can provide sufficient energy for starting the water pump of less power.
- ✓ **Small hydro turbines** power of 1kW-10kW. Building small hydroelectric power plants requires a stable watercourse that do not dry up during the season. In the mountain regions, Serbia has the potential for use of these types of renewable energy that can be of great use in the supply of mountain farms.
- ✓ **Solar concentrator for utilization of solar thermal energy.** These are devices which collect thermal energy emitted from the sun and distribute hot water for additional heating of greenhouses/glasshouses.

The objective to support the production of RE for own consumption in agricultural holding or/and household in rural areas is to affirm and encourage the use of all mentioned devices in agriculture of Serbia, so users of these devices:

- ✓ Have *economic interest* to purchase and use them,
- ✓ Achieve positive results related to *energy efficiency*,
- ✓ To be more reliable in *energy supply*,
- ✓ Assure *permanent protection of land, water and air*, i.e. the environment in long period of time.

The use of analysed *RE generators* can be especially useful and justified in next segments:

- Irrigation in plant production (production of vegetables, fruits, flowers, organic crops), or in starting water pumps (less power) and drop irrigation system and/or periodical irrigation on small surfaces (apply depends on the necessary amount of water, crops which irrigate, areas which irrigate, etc.),
- In agricultural production in mountain areas (production of raspberry, potato, etc.), where there is no energy infrastructure, but with developed network of river courses (using hydro energy of water courses),
- In livestock production (for lighting or the ventilation systems in stables, for starting devices/systems for milking or manuring, for work of lacto freezers; for starting the device for supply of livestock with drinking water),
- For heating greenhouses/glasshouses, fishponds,
- Drying cereals, fruits, vegetables, medicinal and aromatic herbs (driers powered by solar energy, so called solar driers), etc.,
- In organic production,
- In areas of high natural value and/or in the vicinity of protected areas and/or under developed energy infrastructure, where tourism (agro-eco) and/or organic production and/or pasture cattle breeding could develop,
- For lighting farms; supplying drinking water in household; households heating, etc.

Target group of users, these analysed devices for RE production are meant for, are:

- ✓ Family agricultural holdings of small and medium size – the most numerous in Serbian agriculture. In accordance to data of Census of Agriculture in 2012, of total number of agricultural holdings in

- Serbia which dispose with agricultural land (621,445), 92% of them uses agricultural land of 10 ha and less⁷;
- ✓ Younger farmers (not over 44 years of age)⁸, which are engaged in agriculture actively and have a registered agricultural holding. According to Census of Agriculture in the Republic of Serbia in 2012, the share of agricultural holdings of younger farmers in total number of agricultural holdings is 15.9%, UAA of these holdings is 27.2% of total UAA, average UAA per agricultural holding of younger farmers is 9.3 ha, and an average economic size of these holdings (standard output) is 10,160 euros, and almost 10 times more in regard to an average economic size of agricultural holding in Serbia;
 - ✓ Agricultural holdings which realize and/or plan investments in physical assets for agricultural production and processing and marketing of agricultural products (through the use of their own funds/bank credits or subsidies from the agrarian budget). For example, the potential users of analysed generators can be agricultural holdings as users of incentives (grants) of Ministry of Agriculture and Environmental Protection of the Republic of Serbia for purchasing new mechanization and equipment for irrigation: irrigation pumps, generators for starting the pumps (diesel, gasoline and electric powered); the drop irrigation system; the systems of irrigation by sprinkler (Official Gazette of RS, no. 38/16);
 - ✓ Households, legal entities, entrepreneurs, associations in the fields outside of agriculture, for example in traffic and tourism, in remote mountain centres, with no available electro-distribution network (for campers, etc.).

There should be pointed out that ***barriers for using RE power generators in agriculture and rural development for own consumption*** can be:

- ✓ Financial restrictions and low purchasing power of agricultural holdings. The average economic size of agricultural holding in Serbia (data for 2012) amounts 5,918 euros, while in EU-28 is even 30,542 euros (data for 2013) (Cvijanović et al, 2014),

⁷ Physical size of a farm are usually characterized by a size of utilised agricultural area (UAA) and according to this criterion, farms with less than 2 ha or less than 5 ha UAA are defined as small farms (European Commission, Brief AGRI.L.2 – N°2 – July 2011).

⁸ According to EU regulations on support to rural development (Regulation EU No 1305/2013, L 347), young farmer is a person who is not older than 40 years at the time of the request, and who has the adequate professional qualifications and skills, and he takes the office manager of an agricultural holding for the first time.

- ✓ Low level of organisation and association of farmers. The producers are disunited, since cooperatives and associations of farmers are not sufficiently developed (Popović, Paraušić, 2016),
- ✓ Difficulty in accepting innovations (new technologies) by farmers, due to a low educational level, low IT knowledge, conservative attitudes of rural population, etc.,
- ✓ Failure in recognizing the benefits (interests) in using RE,
- ✓ Unsatisfying marketing promotion of RE and energy efficiency.
- ✓ Insufficient training and awareness of farmers.

There is currently no support to agricultural holdings and/or households in rural areas, which produce RE for own needs, although certain laws and programs predict it:

- ✓ ***Law on efficient energy use*** (Official Gazette of RS, no. 25/2013). In compliance with the new law and the Decision on opening the Budget fund for the improvement of energy efficiency of the Republic of Serbia (Official Gazette of RS, no. 92/13), the Budget Fund for the Improvement of Energy Efficiency has started to work in 2014. It should encourage *inter alia* also the use of RE for the production of electrical and thermal energy for ***own needs***, as well as the other activities which aims to use energy more efficiently, through financing or co-financing of the appropriate projects, programs and activities.
- ✓ ***Law on incentives in agriculture and rural development*** (Official Gazette of RS, no. 10/13). The support to investments in RE belongs to the group of incentives for the rural development measures, for the programs of sustainable rural development, which implement in order to improve and protect the environment,
- ✓ ***IPARD program for Serbia for the period 2014-2020*** (Official Gazette of RS, no. 30/2016). Investments in energy production from renewable sources will be supported through the rural development measures, which refer to investments in physical assets of agricultural holdings and the investments which refer to processing and marketing of agricultural products and fishery products, as well as through measures by which encourage the diversification of agricultural holdings and business development, whereby there will be supported only investments in RE power plants for ***own needs*** (sale of electricity to the network is allowed only within the limits of own consumption).

The application of renewable energy sources is closely associated with meteorological conditions and therefore very important to carry out measurement and acquisition of certain meteorological (weather) size, like atmospheric pressure, temperature of air, humidity, quantity of rainfall, solar insolation, wind speed (Despotović et al, 2016).

Conclusions and Recommendations

For all governments, the commitment to sustainable development and energy efficiency, the green economy development and greater use of RE means redefining of legal framework and the system of subsidies, the construction of market infrastructure and market mechanisms, “greening” of public procurements, redirecting public investments into the green economy and strengthening the public-private partnership and cooperation with science-research institutions and civil society organisations.

Serbia's activities and obligations concerning the application of European directives in the field of energy efficiency and RE come from the obligations according to the contract on the Energy Community establishment (Official Gazette of RS, no. 62/06), and they are in accordance to the national legislation adjustment to EU legislation in the field of the *efficient and sustainable use of natural resources (including more efficient use of RE), energy efficiency and the development followed by low emission of gas with the greenhouse effect.*

Preconditions for investments in production and greater use of renewable energy for own needs in the sector of agriculture and rural development of Serbia (development of so called “green” agriculture and sustainable agricultural and rural development) in future period will depend substantially on the following assumptions:

- ✓ ***Financial support to users*** by the state, i.e. Ministry of Agriculture and Environmental Protection and the Ministry of Mining and Energy (subsidies or reliefs to agricultural holdings for purchasing power generators from renewable sources, as well as incentives directed to producers of these devices). Substitution of fossil fuels and electricity from the power grid, electricity from RE (solar and wind energy) requires ***subsidies*** in order to be accepted by farmers. Besides, it will be also important to motivate the business sector to invest in eco-innovations and use resources and energy rationally,
- ✓ ***Providing favourable credit lines***, in order to encourage investments in facilities and devices which use RE,

- ✓ **Informing and education of users (agricultural producers, population of rural areas, etc.)**, especially in remote areas, so agricultural extension and associations of farmers will play an important role in dissemination of knowledge in future,
- ✓ Development and strengthening of **public-private partnership**. The concept of energy cooperatives implies active inclusion and association of local communities and physical persons, aiming to joint venture in energy facilities based on renewable energy, hasn't yet begun to live in Serbia. This form of investments, especially popular in Germany and Denmark, would affect positively on the local areas economy, as well as to wider acceptance of RE technologies⁹.
- ✓ **Increased activities of the local authority units** (towns, municipalities), through programming an annual budgetary support to agriculture and rural development (through the Program of measures for implementation of agricultural and rural development policy) in terms of subsidizing the procurement of equipment and devices for RE production,
- ✓ Possibilities of inclusion into the regional and pan-European flows of rural development and the environmental protection.

Literature

1. Cvijanović Drago, Subić Jonel, Paraušić Vesna, (2014). *Poljoprivredna gazdinstva prema ekonomskoj veličini i tipu proizvodnje u Republici Srbiji*. Republički zavod za statistiku, Beograd, 2014.
2. Despotovic Zeljko, Jovanovic Milos, Stevanovic Ilija (2016). *Possibilities of using renewable energy sources in agriculture in the Republic of Serbia*. Conference paper, December 2016, https://www.researchgate.net/publication/311700168_POSSIBILITIES_OF_USING_RENEWABLE_ENERGY_SOURCES_IN_AGRICULTURE_IN_THE_REPUBLIC_OF_SERBIA Invited lecture (accessed on November 15, 2016).
3. European Commission (2011). *EU Agricultural Economic Briefs. What is a small farm?*, Brief N°2, July 2011.

⁹ <http://zelenirazvoj.org/aktivnosti/mapa-projekata-obnovljivih-izvora-energije/>, accessed on November 15, 2016.

4. KEI (2016). Kancelarija za evropske integracije (European Integration Office). *Nacionalni program za usvajanje pravnih tekovina Evropske unije*.
5. Ministry of Agriculture and Environment of the Republic of Serbia (2016). *Socio-economic and environmental aspects of the use of renewable energy sources in agricultural production in the Republic of Serbia*. Project No. 680-00-0031/ 2016-02.
6. Ministry of Mining and Energy of the Republic of Serbia, Sector for Energy Efficiency and RE, RE Department, Register of privileged electricity producers (23rd November 2016), available at: <http://www.mre.gov.rs/doc/registar23.11.16.html> (date of access 27th November 2016).
7. Official Journal of the European Union L 140 (5.6.2009). *Directive 2009/28/EC of the European Parliament and of the Council of 23 April 2009 on the promotion of the use of energy from renewable sources and amending and subsequently repealing Directives 2001/77/EC and 2003/30/EC*.
8. Official Journal of the European Union L 114 (27.4.2006). *Directive 2006/32/EC of the European Parliament and of the Council of 5 April 2006 on energy end-use efficiency and energy services and repealing Council Directive 93/76/EEC*
9. Official Gazette of RS, No. 38/16 (Službeni glasnik RS, broj 38/16). *Pravilnik o podsticajima za investicije u poljoprivredi za unapređenje konkurentnosti i dostizanje standarda kvaliteta kroz podršku u primarnu proizvodnju biljnih kultura*.
10. Official Gazette of RS, No. 30/16 (Službeni glasnik RS, broj 30/2016). *IPARD program za Srbiju za period 2014-2020*.
11. Official Gazette of RS, No. 113/15 (Službeni glasnik RS, broj 113/2015). *Energetski bilans Republike Srbije za 2016. godinu*.

12. Official Gazette of RS, No. 101/2015 (Službeni glasnik RS, broj 101/2015). *Strategija razvoja energetike Republike Srbije do 2025. godine sa projekcijama do 2030. godine.*
13. Official Gazette of RS, No. 8/2015 (Službeni glasnik RS, broj 8/15). *Izveštaj o sprovođenju Nacionalnog akcionog plana za korišćenje obnovljivih izvora energije.*
14. Official Gazette of RS, No. 145/2014 (Službeni glasnik RS, broj 145/2014). *Zakon o energetici.*
15. Official Gazette of RS, No. 53/13. *National Renewable Energy Action Plan of the Republic of Serbia.* Službeni glasnik RS, broj 53/13. *Nacionalni akcioni plan za korišćenje obnovljivih izvora energije.*
16. Official Gazette of RS, No. 25/2013 (Službeni glasnik RS, broj 25/2013). *Zakon o efikasnom korišćenju energije.*
17. Official Gazette of RS, No. 10/13 (Službeni glasnik RS, broj 10/13). *Zakon o podsticajima u poljoprivredi i ruralnom razvoju.*
18. Official Gazette of RS, No. 62/06 (Službeni glasnik RS, broj 62/06). *Zakon o ratifikaciji Ugovora o osnivanju Energetske zajednice između Evropske zajednice i Republike Albanije, Republike Bugarske, Bosne i Hercegovine, Republike Hrvatske, Bivše Jugoslovenske Republike Makedonije, Republike Crne Gore, Rumunije, Republike Srbije i Privremene Misije UN na Kosovu u skladu sa Rezolucijom 1244 Saveta bezbednosti UN.*
19. Popović Vesna, Paraušić Vesna (2016). *Unapređenje trgovanja u poljoprivredno prehrambenom sektoru Srbije.* Poglavlje u monografiji: „Unapređenje finansijskih znanja i evidencije na poljoprivrednim gazdinstvima u Republici Srbiji“. Institut za ekonomiku poljoprivrede Beograd.
20. REGULATION (EU) No 1305/2013 OF THE EUROPEAN PARLIAMENT AND OF THE COUNCIL of 17 December 2013 on support for rural development by the European Agricultural Fund for Rural Development (EAFRD).

21. Statistical Office of Republic of Serbia/SORS (2016). *Statistical Yearbook of the Republic of Serbia, 2016*.
22. Statistical Office of Republic of Serbia/SORS (2012). *Попис пољопривреде у 2012. у Републици Србији (Census of Agriculture in 2012 in the Republic of Serbia)*. Republički zavod za statistiku, Beograd.
23. UN (2002). *Johannesburg Declaration on Sustainable Development*. World Summit on Sustainable Development. 4 September 2002.
24. UNEP (1992). *The Rio Declaration on Environment and Development, 1992*. The United Nations Conference on Environment and Development, Rio de Janeiro, Brazil, 1992.
25. UNEP (1992a). *Agenda 21*. The United Nations Conference on Environment and Development, Rio de Janeiro, Brazil, 1992.
26. UNDP/UNEP (2012). *Studija o dostignućima i perspektivama na putu ka zelenoj ekonomiji i održivom rastu u Srbiji*. Nacionalni izveštaj za Svetsku konferenciju o održivom razvoju „Rio+20”, Rio de Janeiro, 20–22. jun 2012.
27. Mapa projekata obnovljivih izvora energije u Srbiji, <http://zelenirazvoj.org/aktivnosti/mapa-projekata-obnovljivih-izvora-energije/>(accessed on November 15, 2016)

CIP - Каталогизација у публикацији -
Народна библиотека Србије, Београд

338.43(082)(497.11)
631:502.131.1(082)(497.11)

INTERNATIONAL Scientific Conference Sustainable
Agriculture and Rural Development in Terms of the
Republic of Serbia Strategic Goals Realization Within the
Danube Region (2016 ; Beograd) Development and
Application of Clean Technologies in Agriculture :
thematic proceedings / [International Scientific
Conference] Sustainable Agriculture and Rural
Development in Terms of the Republic of Serbia Strategic
Goals Realization Within the Danube Region, Belgrade,
2016 ; [editors Jonel Subić, Boris Kuzman, Andrei Jean
Vasile]. - Belgrade :
Institute of Agricultural Economics, 2017 (Novi Sad : Mala
knjiga). - IX,
630 str. ; 24 cm : graf. prikazi, tabele

Tiraž 300. - Str. V: Preface / editors. - Napomene i
bibliografske reference uz tekst. - Bibliografija uz svaki rad.

ISBN 978-86-6269-056-2

a) Пољопривреда - Одрживи развој - Србија - Зборници
b) Рурални развој
- Србија - Зборници
COBISS.SR-ID 229320204

